



**CONTRACT PRICING WORKSHEET**  
For MOTOR VEHICLES Only

Contract No.:

HT06-14

Date Prepared:

8/18/2014

This Worksheet is prepared by Contractor and given to End User. If a PO is issued, both documents **MUST** be faxed to H-GAC @ 713-993-4548. Therefore please type or print legibly.

Buying Agency:	Webb County Water Utility	Contractor:	Houston Freightliner, Inc
Contact Person:	Tomas Sanchez	Prepared By:	Michael McCarthy
Phone:	956-523-5586	Phone:	713-580-8122
Fax:		Fax:	713-676-1603
Email:	tomsanchez@webbcountytx.gov	Email:	Mike.McCarthy@STRHouston.com

Product Code:	D1	Description:	2015 Freightliner 114SD
---------------	----	--------------	-------------------------

**A. Product Item Base Unit Price Per Contractor's H-GAC Contract:** 84267

**B. Published Options - Itemize below - Attach additional sheet(s) if necessary - Include Option Code in description if applicable.**  
(Note: Published Options are options which were submitted and priced in Contractor's bid.)

Description	Cost	Description	Cost
	0	Air Conditoner	850
Allison 3000 RDS Transmission	7306	Air Cab Mounts	118
20000 LB Front Axle	2483	Air Ride Driver Seat	175
Hendrickson RT403 40k Rear Suspension	2422	AM/FM Radio	230
Driver Controlled Differential Lock Both Axles	905		
	0		
		Super Products Camel 200 PD Sewer Cleaner	233923.97
7/16x3.5x11 1/8 Frame	760		
1/4" Frame Liner	1058		
RH Outboard Under Step Exhaust with Vertical Stack	629		
		<b>Subtotal From Additional Sheet(s):</b>	
	0	<b>Subtotal B:</b>	250859.97

**C. Unpublished Options - Itemize below / attach additional sheet(s) if necessary.**  
(Note: Unpublished options are items which were not submitted and priced in Contractor's bid.)

Description	Cost	Description	Cost
		<b>Subtotal From Additional Sheet(s):</b>	
		<b>Subtotal C:</b>	0

**Check:** Total cost of Unpublished Options (C) cannot exceed 25% of the total of the Base Unit Price plus Published Options (A+B). For this transaction the percentage is: 0%

**D. Total Cost Before Any Applicable Trade-In / Other Allowances / Discounts (A+B+C)**

Quantity Ordered:	1	X Subtotal of A + B + C:	335126.97	=	Subtotal D:	335126.97
-------------------	---	--------------------------	-----------	---	-------------	-----------

**E. H-GAC Order Processing Charge (Amount Per Current Policy)** Subtotal E: 1500

**F. Trade-Ins / Special Discounts / Other Allowances / Freight / Installation / Miscellaneous Charges**

Description	Cost	Description	Cost
Discount	-2935		
		<b>Subtotal F:</b>	-2935

**Delivery Date:** 130-160 Days ARO **G. Total Purchase Price (D+E+F):** 333691.97

Prepared for:  
Tomas Sanchez  
Webb County Water Utility  
1000 Houston St  
Laredo, TX 78040  
Phone: 956-523-5586

Prepared by:  
Michael McCarthy  
HOUSTON FREIGHTLINER,  
WESTERN STAR  
9550 NORTH LOOP EAST  
HOUSTON, TX 77029  
Phone: 713-580-8122  
E-Mail:  
mmccarthy@strhouston.com

*A proposal for*  
**Webb County Water Utility**

*Prepared by*  
**HOUSTON FREIGHTLINER, WESTERN STAR**  
*Michael McCarthy*

*Aug 19, 2014*

**Freightliner 114SD**

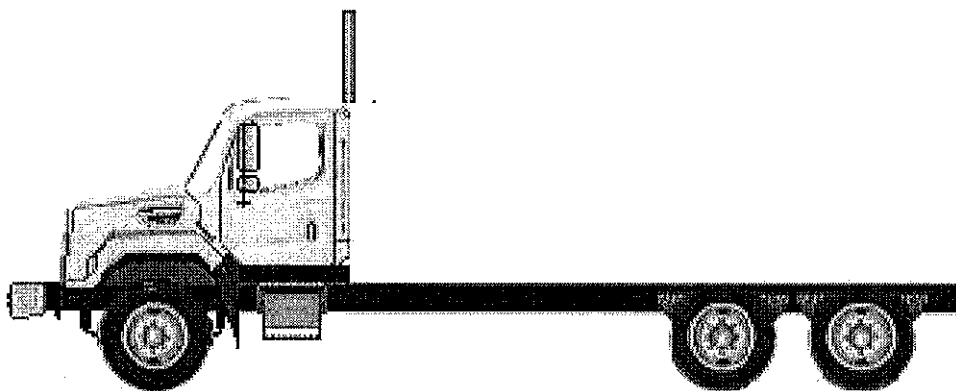

Components shown may not reflect all spec'd options and are not to scale



Prepared for:  
 Tomas Sanchez  
 Webb County Water Utility  
 1000 Houston St  
 Laredo, TX 78040  
 Phone: 956-523-5586

Prepared by:  
 Michael McCarthy  
 HOUSTON FREIGHTLINER,  
 WESTERN STAR  
 9550 NORTH LOOP EAST  
 HOUSTON, TX 77029  
 Phone: 713-580-8122  
 E-Mail:  
 mmccarthy@strhouston.com

## S P E C I F I C A T I O N   P R O P O S A L

Data Code	Description	Weight Front	Weight Rear
<b>Price Level</b>			
PRL-09D	SD PRL-09D (EFF:08/05/14)		
<b>Data Version</b>			
DRL-003	SPECPRO21 DATA RELEASE VER 003		
<b>Vehicle Configuration</b>			
001-177	114SD CONVENTIONAL CHASSIS	8,005	6,680
004-215	2015 MODEL YEAR SPECIFIED		
002-004	SET BACK AXLE - TRUCK	480	-480
019-002	STRAIGHT TRUCK PROVISION		
003-001	LH PRIMARY STEERING LOCATION		
<b>General Service</b>			
AA1-002	TRUCK CONFIGURATION		
AA6-002	DOMICILED, USA (EXCLUDING CALIFORNIA AND CARB OPT-IN STATES)		
A85-002	PICKUP AND DELIVERY/SHORT HAUL SERVICE		
A84-1GM	GOVERNMENT BUSINESS SEGMENT		
AA4-002	LIQUID BULK COMMODITY		
AA5-002	TERRAIN/DUTY: 100% (ALL) OF THE TIME, IN TRANSIT, IS SPENT ON PAVED ROADS		
AB1-008	MAXIMUM 8% EXPECTED GRADE		
AB5-001	SMOOTH CONCRETE OR ASPHALT PAVEMENT - MOST SEVERE IN-TRANSIT (BETWEEN SITES) ROAD SURFACE		
995-1AE	FREIGHTLINER LEVEL II WARRANTY		
A66-99D	EXPECTED FRONT AXLE(S) LOAD : 20000.0 lbs		
A68-99D	EXPECTED REAR DRIVE AXLE(S) LOAD : 40000.0 lbs		
A63-99D	EXPECTED GROSS VEHICLE WEIGHT CAPACITY : 60000.0 lbs		
<b>Truck Service</b>			



Prepared for:  
 Tomas Sanchez  
 Webb County Water Utility  
 1000 Houston St  
 Laredo, TX 78040  
 Phone: 956-523-5586

Prepared by:  
 Michael McCarthy  
 HOUSTON FREIGHTLINER,  
 WESTERN STAR  
 9550 NORTH LOOP EAST  
 HOUSTON, TX 77029  
 Phone: 713-580-8122  
 E-Mail:  
 mmccarthy@strhouston.com

Data Code	Description	Weight Front	Weight Rear
AA3-003	TANK BODY		
A88-99D	EXPECTED TRUCK BODY LENGTH : 0.0 ft		

**Engine**

101-2XN	CUM ISL 370 HP @ 2000 RPM, 2100 GOV RPM, 1250 LB/FT @ 1400 RPM	-850	-70
---------	--	------	-----

**Electronic Parameters**

79A-075	75 MPH ROAD SPEED LIMIT		
79B-000	CRUISE CONTROL SPEED LIMIT SAME AS ROAD SPEED LIMIT		
79K-007	PTO MODE ENGINE RPM LIMIT - 1100 RPM		
79M-001	PTO MODE BRAKE OVERRIDE - SERVICE BRAKE APPLIED		
79P-003	PTO RPM WITH CRUISE SET SWITCH - 800 RPM		
79Q-002	PTO RPM WITH CRUISE RESUME SWITCH - 700 RPM		
79S-001	PTO MODE CANCEL VEHICLE SPEED - 5 MPH		
79U-007	PTO GOVERNOR RAMP RATE - 250 RPM PER SECOND		
80G-002	PTO MINIMUM RPM - 700		
80J-002	REGEN INHIBIT SPEED THRESHOLD - 5 MPH		

**Engine Equipment**

99C-013	2013 ONBOARD DIAGNOSTICS/2010 EPA/CARB/GHG14		
99D-010	NO 2008 CARB EMISSION CERTIFICATION		
13E-001	STANDARD OIL PAN		
105-001	ENGINE MOUNTED OIL CHECK AND FILL		
014-099	SIDE OF HOOD AIR INTAKE WITH FIREWALL MOUNTED DONALDSON AIR CLEANER		
124-1D7	DR 12V 160 AMP 28-SI QUADRAMOUNT PAD ALTERNATOR WITH REMOTE BATTERY VOLT SENSE		
292-098	(2) ALLIANCE MODEL 1231, GROUP 31, 12 VOLT MAINTENANCE FREE 2250 CCA THREADED STUD BATTERIES	-50	-10
290-017	BATTERY BOX FRAME MOUNTED		
281-001	STANDARD BATTERY JUMPERS		
282-001	SINGLE BATTERY BOX FRAME MOUNTED LH SIDE UNDER CAB		
291-017	WIRE GROUND RETURN FOR BATTERY CABLES WITH ADDITIONAL FRAME GROUND RETURN		



Prepared for:  
 Tomas Sanchez  
 Webb County Water Utility  
 1000 Houston St  
 Laredo, TX 78040  
 Phone: 956-523-5586

Prepared by:  
 Michael McCarthy  
 HOUSTON FREIGHTLINER,  
 WESTERN STAR  
 9550 NORTH LOOP EAST  
 HOUSTON, TX 77029  
 Phone: 713-580-8122  
 E-Mail:  
 mmccarthy@strhouston.com

Data Code	Description	Weight Front	Weight Rear
289-001	NON-POLISHED BATTERY BOX COVER		
107-032	CUMMINS TURBOCHARGED 18.7 CFM AIR COMPRESSOR WITH INTERNAL SAFETY VALVE		
152-041	ELECTRONIC ENGINE INTEGRAL SHUTDOWN PROTECTION SYSTEM		
128-076	CUMMINS EXHAUST BRAKE INTEGRAL WITH VARIABLE GEOMETRY TURBO WITH ON/OFF DASH SWITCH	20	
016-1C2	RH OUTBOARD UNDER STEP MOUNTED HORIZONTAL AFTERTREATMENT SYSTEM ASSEMBLY WITH RH B-PILLAR MOUNTED VERTICAL TAILPIPE	30	25
28F-007	ENGINE AFTERTREATMENT DEVICE, AUTOMATIC OVER THE ROAD ACTIVE REGENERATION AND DASH MOUNTED SINGLE REGENERATION REQUEST/INHIBIT SWITCH		
239-020	10 FOOT 00 INCH (120 INCH+0/-5 INCH) EXHAUST SYSTEM HEIGHT		
237-1CR	RH CURVED VERTICAL TAILPIPE B-PILLAR MOUNTED ROUTED FROM STEP		
23U-001	6 GALLON DIESEL EXHAUST FLUID TANK	-40	-20
30N-003	100 PERCENT DIESEL EXHAUST FLUID FILL		
23Y-001	STANDARD DIESEL EXHAUST FLUID PUMP MOUNTING		
43X-002	LH MEDIUM DUTY STANDARD DIESEL EXHAUST FLUID TANK LOCATION		
43Y-001	STANDARD DIESEL EXHAUST FLUID TANK CAP		
242-011	ALUMINUM AFTERTREATMENT DEVICE/MUFFLER/TAILOPIPE SHIELD(S)		
273-018	HORTON DRIVEMASTER ON/OFF FAN DRIVE		
276-001	AUTOMATIC FAN CONTROL WITHOUT DASH SWITCH, NON ENGINE MOUNTED		
110-003	CUMMINS SPIN ON FUEL FILTER		
118-008	COMBINATION FULL FLOW/BYPASS OIL FILTER		
266-017	1300 SQUARE INCH ALUMINUM RADIATOR	-20	
103-036	ANTIFREEZE TO -34F, ETHYLENE GLYCOL PRE-CHARGED SCA HEAVY DUTY COOLANT		
171-007	GATES BLUE STRIPE COOLANT HOSES OR EQUIVALENT		
172-001	CONSTANT TENSION HOSE CLAMPS FOR COOLANT HOSES		
270-016	RADIATOR DRAIN VALVE		
132-004	ELECTRIC GRID AIR INTAKE WARMER		



Prepared for:  
 Tomas Sanchez  
 Webb County Water Utility  
 1000 Houston St  
 Laredo, TX 78040  
 Phone: 956-523-5586

Prepared by:  
 Michael McCarthy  
 HOUSTON FREIGHTLINER,  
 WESTERN STAR  
 9550 NORTH LOOP EAST  
 HOUSTON, TX 77029  
 Phone: 713-580-8122  
 E-Mail:  
 mmccarthy@strhouston.com

Data Code	Description	Weight Front	Weight Rear
155-055	DELCO 12V 39MT HD/OCP STARTER WITH THERMAL PROTECTION AND INTEGRATED MAGNETIC SWITCH		

**Transmission**

342-582	ALLISON 3000 RDS AUTOMATIC TRANSMISSION WITH PTO PROVISION	-80	-20
---------	--	-----	-----

**Transmission Equipment**

343-338	ALLISON VOCATIONAL PACKAGE 222 - AVAILABLE ON 3000/4000 PRODUCT FAMILIES WITH VOCATIONAL MODEL RDS		
84B-012	ALLISON VOCATIONAL RATING FOR ON/OFF HIGHWAY APPLICATIONS AVAILABLE WITH ALL PRODUCT FAMILIES		
84C-023	PRIMARY MODE GEARS, LOWEST GEAR 1, START GEAR 1, HIGHEST GEAR 6, AVAILABLE FOR 3000/4000 PRODUCT FAMILIES ONLY		
84D-023	SECONDARY MODE GEARS, LOWEST GEAR 1, START GEAR 1, HIGHEST GEAR 6, AVAILABLE FOR 3000/4000 PRODUCT FAMILIES ONLY		
353-023	VEHICLE INTERFACE WIRING WITH BODY BUILDER CONNECTOR MOUNTED END OF FRAME		
34C-001	ELECTRONIC TRANSMISSION CUSTOMER ACCESS CONNECTOR FIREWALL MOUNTED		
362-818	CUSTOMER INSTALLED CHELSEA 870 SERIES PTO		
363-001	PTO MOUNTING, LH SIDE OF MAIN TRANSMISSION		
341-018	MAGNETIC PLUGS, ENGINE DRAIN, TRANSMISSION DRAIN, AXLE(S) FILL AND DRAIN		
345-003	PUSH BUTTON ELECTRONIC SHIFT CONTROL, DASH MOUNTED		
97G-004	TRANSMISSION PROGNOSTICS - ENABLED 2013		
370-015	WATER TO OIL TRANSMISSION COOLER, IN RADIATOR END TANK		
346-003	TRANSMISSION OIL CHECK AND FILL WITH ELECTRONIC OIL LEVEL CHECK		
35T-001	SYNTHETIC TRANSMISSION FLUID (TES-295 COMPLIANT)		

**Front Axle and Equipment**

400-1BB	DETROIT DA-F-20.0-5 20,000# FL1 71.0 KPI/3.74 DROP SINGLE FRONT AXLE	210	
---------	--	-----	--



Prepared for:  
 Tomas Sanchez  
 Webb County Water Utility  
 1000 Houston St  
 Laredo, TX 78040  
 Phone: 956-523-5586

Prepared by:  
 Michael McCarthy  
 HOUSTON FREIGHTLINER,  
 WESTERN STAR  
 9550 NORTH LOOP EAST  
 HOUSTON, TX 77029  
 Phone: 713-580-8122  
 E-Mail:  
 mmccarthy@strhouston.com

Data Code	Description	Weight Front	Weight Rear
402-030	MERITOR 16.5X6 Q+ CAST SPIDER CAM FRONT BRAKES, DOUBLE ANCHOR, FABRICATED SHOES		
403-002	NON-ASBESTOS FRONT BRAKE LINING		
419-023	CONMET CAST IRON FRONT BRAKE DRUMS		
409-021	SKF SCOTSEAL PLUS XL FRONT OIL SEALS		
408-001	VENTED FRONT HUB CAPS WITH WINDOW, CENTER AND SIDE PLUGS - OIL		
416-022	STANDARD SPINDLE NUTS FOR ALL AXLES		
405-002	MERITOR AUTOMATIC FRONT SLACK ADJUSTERS		
406-001	STANDARD KING PIN BUSHINGS		
536-055	TRW THP-60 POWER STEERING WITH RCH45 AUXILIARY GEAR	130	
539-003	POWER STEERING PUMP		
534-003	4 QUART POWER STEERING RESERVOIR	5	
533-001	OIL/AIR POWER STEERING COOLER	5	
40T-001	ORGANIC SAE 80/90 FRONT AXLE LUBE		

**Front Suspension**

620-006	20,000# FLAT LEAF FRONT SUSPENSION	310	
619-004	GRAPHITE BRONZE BUSHINGS WITH SEALS - FRONT SUSPENSION		
410-001	FRONT SHOCK ABSORBERS		

**Rear Axle and Equipment**

420-1K3	MT-40-14X 40,000# R-SERIES TANDEM REAR AXLE		-40
421-529	5.29 REAR AXLE RATIO		
424-003	IRON REAR AXLE CARRIER WITH OPTIONAL HEAVY DUTY AXLE HOUSING		40
385-005	DRIVELINE SPACER FOR CUSTOMER FURNISHED EQUIPMENT		
386-073	MXL 17T MERITOR EXTENDED LUBE MAIN DRIVELINE WITH HALF ROUND YOKES	25	25
388-073	MXL 17T MERITOR EXTENDED LUBE INTERAXLE DRIVELINE WITH HALF ROUND YOKES		
878-019	(1) INTERAXLE LOCK VALVE FOR TANDEM OR TRIDEM DRIVE AXLES		
87A-001	BLINKING LAMP WITH EACH MODE SWITCH, INTERAXLE UNLOCK DEFAULT WITH IGNITION OFF		



Prepared for:  
 Tomas Sanchez  
 Webb County Water Utility  
 1000 Houston St  
 Laredo, TX 78040  
 Phone: 956-523-5586

Prepared by:  
 Michael McCarthy  
 HOUSTON FREIGHTLINER,  
 WESTERN STAR  
 9550 NORTH LOOP EAST  
 HOUSTON, TX 77029  
 Phone: 713-580-8122  
 E-Mail:  
 mmccarthy@strhouston.com

Data Code	Description	Weight Front	Weight Rear
423-020	MERITOR 16.5X7 Q+ CAST SPIDER CAM REAR BRAKES, DOUBLE ANCHOR, FABRICATED SHOES		
433-002	NON-ASBESTOS REAR BRAKE LINING		
434-003	STANDARD BRAKE CHAMBER LOCATION		
451-023	CONMET CAST IRON REAR BRAKE DRUMS		
425-002	REAR BRAKE DUST SHIELDS		10
440-021	SKF SCOTSEAL PLUS XL REAR OIL SEALS		
426-099	HALDEX GOLDSEAL LONGSTROKE HEAVY DUTY 30/36 2-DRIVE AXLES SPRING PARKING CHAMBERS		
428-003	HALDEX AUTOMATIC REAR SLACK ADJUSTERS		
41T-001	ORGANIC SAE 80/90 REAR AXLE LUBE		

**Rear Suspension**

622-1CN	HENDRICKSON RTE403 REAR SUSPENSION @ 40,000#		720
621-015	HENDRICKSON RT/RTE - 6.00" SADDLE		
431-001	STANDARD U-BOLT PAD		
624-009	54 INCH AXLE SPACING		10
628-004	STEEL BEAMS AND RUBBER CENTER BUSHINGS WITH BAR PIN ADJUSTABLE END CONNECTIONS		
623-005	FORE/AFT CONTROL RODS		

**Brake System**

490-100	WABCO 4S/4M ABS WITHOUT TRACTION CONTROL		
871-001	REINFORCED NYLON, FABRIC BRAID AND WIRE BRAID CHASSIS AIR LINES		
904-001	FIBER BRAID PARKING BRAKE HOSE		
412-001	STANDARD BRAKE SYSTEM VALVES		
46D-002	STANDARD AIR SYSTEM PRESSURE PROTECTION SYSTEM		
413-002	STD U.S. FRONT BRAKE VALVE		
432-003	RELAY VALVE WITH 5-8 PSI CRACK PRESSURE, NO REAR PROPORTIONING VALVE		
480-009	BW AD-9 BRAKE LINE AIR DRYER WITH HEATER	20	
479-007	AIR DRYER MOUNTED OUTBOARD ON RH RAIL BACK OF CAB		
460-014	STEEL AIR TANKS MOUNTED BELOW FRAME RAILS	5	5





Prepared for:  
 Tomas Sanchez  
 Webb County Water Utility  
 1000 Houston St  
 Laredo, TX 78040  
 Phone: 956-523-5586

Prepared by:  
 Michael McCarthy  
 HOUSTON FREIGHTLINER,  
 WESTERN STAR  
 9550 NORTH LOOP EAST  
 HOUSTON, TX 77029  
 Phone: 713-580-8122  
 E-Mail:  
 mmccarthy@strhouston.com

Data Code	Description	Weight Front	Weight Rear
607-001	CLEAR FRAME RAILS FROM BACK OF CAB TO FRONT REAR SUSPENSION BRACKET, BOTH RAILS OUTBOARD		
477-001	PULL CABLE ON WET TANK, PETCOCK DRAIN VALVES ON ALL OTHER AIR TANKS		

**Trailer Connections**

335-004	UPGRADED CHASSIS MULTIPLEXING UNIT		
---------	------------------------------------	--	--

**Wheelbase & Frame**

545-645	6450MM (254 INCH) WHEELBASE		
546-101	11/32X3-1/2X10-15/16 INCH STEEL FRAME (8.73MMX277.8MM/0.344X10.94 INCH) 120KSI	330	110
547-001	1/4 INCH (6.35MM) C-CHANNEL INNER FRAME REINFORCEMENT	250	430
552-023	1325MM (52 INCH) REAR FRAME OVERHANG		
55W-005	FRAME OVERHANG RANGE: 51 INCH TO 60 INCH	20	-70
549-016	24 INCH INTEGRAL FRONT FRAME EXTENSION WITH 0.25 INCH INSERT	325	-50
AC8-99D	CALC'D BACK OF CAB TO REAR SUSP C/L (CA) : 188.45 in		
AE8-99D	CALCULATED EFFECTIVE BACK OF CAB TO REAR SUSPENSION C/L (CA) : 185.45 in		
AE4-99D	CALC'D FRAME LENGTH - OVERALL : 375.61		
AM6-99D	CALC'D SPACE AVAILABLE FOR DECKPLATE : 188.45 in		
FSS-0LH	CALCULATED FRAME SPACE LH SIDE : 116.74 in		
FSS-0RH	CALCULATED FRAME SPACE RH SIDE : 141.48 in		
553-001	SQUARE END OF FRAME		
550-001	FRONT CLOSING CROSSMEMBER		
559-001	STANDARD WEIGHT ENGINE CROSSMEMBER		
562-001	STANDARD MIDSHIP #1 CROSSMEMBER(S)		
572-001	STANDARD REARMOST CROSSMEMBER		
565-001	STANDARD SUSPENSION CROSSMEMBER		

**Chassis Equipment**

556-997	OMIT FRONT BUMPER, CUSTOMER INSTALLED SPECIAL BUMPER, DOES NOT COMPLY WITH FMCSR 393.203	-100	
551-007	GRADE 8 THREADED HEX HEADED FRAME FASTENERS		



Prepared for:  
 Tomas Sanchez  
 Webb County Water Utility  
 1000 Houston St  
 Laredo, TX 78040  
 Phone: 956-523-5586

Prepared by:  
 Michael McCarthy  
 HOUSTON FREIGHTLINER,  
 WESTERN STAR  
 9550 NORTH LOOP EAST  
 HOUSTON, TX 77029  
 Phone: 713-580-8122  
 E-Mail:  
 mmccarthy@strhouston.com

Data Code	Description	Weight Front	Weight Rear
<b>Fuel Tanks</b>			
204-152	70 GALLON/264 LITER ALUMINUM FUEL TANK - LH	5	
218-001	23 INCH DIAMETER FUEL TANK(S)		
215-005	PLAIN ALUMINUM/PAINTED STEEL FUEL/HYDRAULIC TANK(S) WITH PAINTED BANDS		
212-007	FUEL TANK(S) FORWARD		
664-001	PLAIN STEP FINISH		
205-001	FUEL TANK CAP(S)		
122-076	ALLIANCE FUEL FILTER/WATER SEPARATOR WITH HEATED BOWL	15	
216-020	EQUIFLO INBOARD FUEL SYSTEM		
202-016	HIGH TEMPERATURE REINFORCED NYLON FUEL LINE		
<b>Tires</b>			
093-0TB	MICHELIN XZY-3 425/65R22.5 20 PLY RADIAL FRONT TIRES	196	
094-0DH	MICHELIN XDE M/S 11R22.5 14 PLY RADIAL REAR TIRES		56
<b>Hubs</b>			
418-056	CONMET PRESET PLUS IRON FRONT HUBS		
450-056	CONMET PRESET PLUS IRON REAR HUBS		
<b>Wheels</b>			
502-566	MAXION WHEELS 10035 22.5X12.25 10-HUB PILOT 4.75 INSET 5-HAND STEEL DISC FRONT WHEELS	86	
505-524	MAXION WHEELS 90541 22.5X8.25 10-HUB PILOT 2-HAND STEEL DISC REAR WHEELS		-64
<b>Cab Exterior</b>			
829-1A2	114 INCH BBC FLAT ROOF ALUMINUM CONVENTIONAL CAB		
650-008	AIR CAB MOUNTS		
648-002	NONREMOVABLE BUGSCREEN MOUNTED BEHIND GRILLE		
754-017	BOLT-ON MOLDED FLEXIBLE FENDER EXTENSIONS	10	
678-001	LH AND RH GRAB HANDLES		
645-002	BRIGHT FINISH RADIATOR SHELL/HOOD BEZEL		



Prepared for:  
 Tomas Sanchez  
 Webb County Water Utility  
 1000 Houston St  
 Laredo, TX 78040  
 Phone: 956-523-5586

Prepared by:  
 Michael McCarthy  
 HOUSTON FREIGHTLINER,  
 WESTERN STAR  
 9550 NORTH LOOP EAST  
 HOUSTON, TX 77029  
 Phone: 713-580-8122  
 E-Mail:  
 mmccarthy@strhouston.com

Data Code	Description	Weight Front	Weight Rear
646-042	STATIONARY BLACK GRILLE WITH BRIGHT ACCENTS		
65X-003	CHROME HOOD MOUNTED AIR INTAKE GRILLE		
644-004	FIBERGLASS HOOD		
690-007	HOOD LINER INSULATION WITH SINGLE FIREWALL INSULATION		
727-998	NO AIR HORN	-4	
726-001	SINGLE ELECTRIC HORN		
657-1CV	DOOR LOCKS AND IGNITION SWITCH KEYED THE SAME WITH (4) KEYS		
312-067	HALOGEN COMPOSITE HEADLAMPS WITH BRIGHT BEZELS		
302-047	LED AERODYNAMIC MARKER LIGHTS		
311-012	DAYTIME RUNNING LIGHTS - LOW BEAM ONLY		
294-046	OMIT STOP/TAIL/BACKUP LIGHTS AND PROVIDE WIRING WITH SEPARATE STOP/TURN WIRES TO 4 FEET BEYOND END OF FRAME		-5
300-015	STANDARD FRONT TURN SIGNAL LAMPS		
744-1BH	DUAL WEST COAST MOLDED-IN COLOR MIRRORS		
797-001	DOOR MOUNTED MIRRORS		
796-001	102 INCH EQUIPMENT WIDTH		
743-1AP	LH AND RH 8 INCH MOLDED-IN COLOR CONVEX MIRRORS MOUNTED UNDER PRIMARY MIRRORS		
729-001	STANDARD SIDE/REAR REFLECTORS		
677-998	NO CAB MOUNTED STEPS		
768-043	63X14 INCH TINTED REAR WINDOW		
661-004	TINTED DOOR GLASS LH AND RH WITH TINTED OPERATING WING WINDOWS		
654-011	RH AND LH ELECTRIC POWERED WINDOWS	4	
663-013	TINTED WINDSHIELD		
659-020	2 GALLON WINDSHIELD WASHER RESERVOIR WITH FLUID LEVEL INDICATOR, FRAME MOUNTED		

**Cab Interior**

707-1AK	OPAL GRAY VINYL INTERIOR		
706-026	MOLDED PLASTIC DOOR PANEL WITHOUT VINYL INSERT WITH ALUMINUM KICKPLATE LOWER DOOR		



Prepared for:  
 Tomas Sanchez  
 Webb County Water Utility  
 1000 Houston St  
 Laredo, TX 78040  
 Phone: 956-523-5586

Prepared by:  
 Michael McCarthy  
 HOUSTON FREIGHTLINER,  
 WESTERN STAR  
 9550 NORTH LOOP EAST  
 HOUSTON, TX 77029  
 Phone: 713-580-8122  
 E-Mail:  
 mmccarthy@strhouston.com

Data Code	Description	Weight Front	Weight Rear
708-026	MOLDED PLASTIC DOOR PANEL WITHOUT VINYL INSERT WITH ALUMINUM KICKPLATE LOWER DOOR		
772-006	BLACK MATS WITH SINGLE INSULATION		
691-008	FORWARD ROOF MOUNTED CONSOLE WITH UPPER STORAGE COMPARTMENTS WITHOUT NETTING		
694-010	IN DASH STORAGE BIN		
742-007	(2) CUP HOLDERS LH AND RH DASH		
680-006	GRAY/CHARCOAL FLAT DASH		
720-003	5 LB. FIRE EXTINGUISHER	10	
700-002	HEATER, DEFROSTER AND AIR CONDITIONER		
701-001	STANDARD HVAC DUCTING		
703-005	MAIN HVAC CONTROLS WITH RECIRCULATION SWITCH		
170-015	STANDARD HEATER PLUMBING		
130-033	DENSO HEAVY DUTY AIR CONDITIONER COMPRESSOR		
702-002	BINARY CONTROL, R-134A		
739-033	STANDARD INSULATION		
285-013	SOLID-STATE CIRCUIT PROTECTION AND FUSES		
280-007	12V NEGATIVE GROUND ELECTRICAL SYSTEM		
324-014	DOMELIGHT WITH 3-WAY SWITCH ACTIVATED BY LH AND RH DOORS		
655-005	LH AND RH ELECTRIC DOOR LOCKS		
284-023	(1) 12 VOLT POWER SUPPLY IN DASH		
722-002	TRIANGULAR REFLECTORS WITHOUT FLARES	10	
756-1J3	BASIC HIGH BACK AIR SUSPENSION DRIVER SEAT WITH MECHANICAL LUMBAR AND INTEGRATED CUSHION EXTENSION	30	
760-1DC	BASIC HIGH BACK NON SUSPENSION PASSENGER SEAT		
711-004	LH AND RH INTEGRAL DOOR PANEL ARMRESTS		
758-014	BLACK CORDURA PLUS CLOTH DRIVER SEAT COVER		
761-014	BLACK CORDURA PLUS CLOTH PASSENGER SEAT COVER		
763-032	3 POINT FIXED D-RING RETRACTOR DRIVER AND PASSENGER SEAT BELTS		
532-002	ADJUSTABLE TILT AND TELESCOPING STEERING COLUMN	10	



Prepared for:  
 Tomas Sanchez  
 Webb County Water Utility  
 1000 Houston St  
 Laredo, TX 78040  
 Phone: 956-523-5586

Prepared by:  
 Michael McCarthy  
 HOUSTON FREIGHTLINER,  
 WESTERN STAR  
 9550 NORTH LOOP EAST  
 HOUSTON, TX 77029  
 Phone: 713-580-8122  
 E-Mail:  
 mmccarthy@strhouston.com

Data Code	Description	Weight Front	Weight Rear
540-015	4-SPOKE 18 INCH (450MM) STEERING WHEEL		
765-002	DRIVER AND PASSENGER INTERIOR SUN VISORS		
<b>Instruments &amp; Controls</b>			
732-004	GRAY DRIVER INSTRUMENT PANEL		
734-004	GRAY CENTER INSTRUMENT PANEL		
87L-001	ENGINE REMOTE INTERFACE WITH PARK BRAKE INTERLOCK		
870-001	BLACK GAUGE BEZELS		
486-001	LOW AIR PRESSURE LIGHT AND BUZZER		
840-002	2 INCH PRIMARY AND SECONDARY AIR PRESSURE GAUGES		
198-998	NO AIR CLEANER RESTRICTION GAUGE		
721-001	97 DB BACKUP ALARM		3
149-013	ELECTRONIC CRUISE CONTROL WITH SWITCHES IN LH SWITCH PANEL		
156-007	KEY OPERATED IGNITION SWITCH AND INTEGRAL START POSITION; 4 POSITION OFF/RUN/START/ACCESSORY		
811-011	ODOMETER/TRIP/HOUR/DIAGNOSTIC/VOLTAGE DISPLAY: 1X7 CHARACTER, 26 WARNING LAMPS, DATA LINKED, ICU3		
160-025	DIAGNOSTIC INTERFACE CONNECTOR, 9 PIN, SAE J1939, LOCATED BELOW DASH		
844-001	2 INCH ELECTRIC FUEL GAUGE		
148-073	ENGINE REMOTE INTERFACE FOR REMOTE THROTTLE		
163-004	ENGINE REMOTE INTERFACE CONNECTOR IN ENGINE COMPARTMENT		
856-001	ELECTRICAL ENGINE COOLANT TEMPERATURE GAUGE		
864-001	2 INCH TRANSMISSION OIL TEMPERATURE GAUGE		
830-017	ENGINE AND TRIP HOUR METERS INTEGRAL WITHIN DRIVER DISPLAY		
372-051	CUSTOMER FURNISHED AND INSTALLED PTO CONTROLS		
852-002	ELECTRIC ENGINE OIL PRESSURE GAUGE		
746-1A9	AM/FM RADIO WITH FRONT AND REAR AUXILIARY INPUTS AND J1939	10	
747-001	DASH MOUNTED RADIO		
750-002	(2) RADIO SPEAKERS IN CAB		



Prepared for:  
 Tomas Sanchez  
 Webb County Water Utility  
 1000 Houston St  
 Laredo, TX 78040  
 Phone: 956-523-5586

Prepared by:  
 Michael McCarthy  
 HOUSTON FREIGHTLINER,  
 WESTERN STAR  
 9550 NORTH LOOP EAST  
 HOUSTON, TX 77029  
 Phone: 713-580-8122  
 E-Mail:  
 mmccarthy@strhouston.com

Data Code	Description	Weight Front	Weight Rear
753-001	AM/FM ANTENNA MOUNTED ON FORWARD LH ROOF	2	
748-006	POWER AND GROUND WIRING PROVISION		
749-016	CB WIRING ONLY TO ROOF/OVERHEAD CONSOLE; NO MOUNTING PROVISION		
810-027	ELECTRONIC MPH SPEEDOMETER WITH SECONDARY KPH SCALE, WITHOUT ODOMETER		
812-001	ELECTRONIC 3000 RPM TACHOMETER		
813-998	NO MPH AND/OR RPM GRAPH	-5	
162-002	IGNITION SWITCH CONTROLLED ENGINE STOP		
81Y-001	PRE-FLIGHT, ALL OUTPUTS FLASH WITH SMART SWITCH		
836-015	DIGITAL VOLTAGE DISPLAY INTEGRAL WITH DRIVER DISPLAY		
660-008	SINGLE ELECTRIC WINDSHIELD WIPER MOTOR WITH DELAY		
304-001	MARKER LIGHT SWITCH INTEGRAL WITH HEADLIGHT SWITCH		
882-009	ONE VALVE PARKING BRAKE SYSTEM WITH WARNING INDICATOR		
299-013	SELF CANCELING TURN SIGNAL SWITCH WITH DIMMER, WASHER/WIPER AND HAZARD IN HANDLE		
298-039	INTEGRAL ELECTRONIC TURN SIGNAL FLASHER WITH HAZARD LAMPS OVERRIDING STOP LAMPS		

**Design**

065-000	PAINT: ONE SOLID COLOR
---------	------------------------

**Color**

980-3F6	CAB COLOR A: N0006EA WHITE ELITE SS
986-020	BLACK, HIGH SOLIDS POLYURETHANE CHASSIS PAINT
962-962	MAXION WHEELS W POWDER WHITE (N0006EA) FRONT WHEELS/RIMS
966-962	MAXION WHEELS W POWDER WHITE (N0006EA) REAR WHEELS/RIMS

**Certification/Compliance**

996-001	U.S. FMVSS CERTIFICATION, EXCEPT SALES CABS AND GLIDER KITS
---------	---

**Secondary Factory Options**



Prepared for:  
 Tomas Sanchez  
 Webb County Water Utility  
 1000 Houston St  
 Laredo, TX 78040  
 Phone: 956-523-5586

Prepared by:  
 Michael McCarthy  
 HOUSTON FREIGHTLINER,  
 WESTERN STAR  
 9550 NORTH LOOP EAST  
 HOUSTON, TX 77029  
 Phone: 713-580-8122  
 E-Mail:  
 mmccarthy@strhouston.com

Data Code	Description	Weight Front	Weight Rear
998-001	CORPORATE PDI CENTER IN-SERVICE ONLY		

**TOTAL VEHICLE SUMMARY**

**Weight Summary**

	Weight Front	Weight Rear	Total Weight
Factory Weight <sup>+</sup>	9409 lbs	7285 lbs	16694 lbs
<b>Total Weight<sup>+</sup></b>	<b>9409 lbs</b>	<b>7285 lbs</b>	<b>16694 lbs</b>

(+) Weights shown are estimates only.  
 If weight is critical, contact Customer Application Engineering.



Prepared for:  
 Tomas Sanchez  
 Webb County Water Utility  
 1000 Houston St  
 Laredo, TX 78040  
 Phone: 956-523-5586

Prepared by:  
 Michael McCarthy  
 HOUSTON FREIGHTLINER,  
 WESTERN STAR  
 9550 NORTH LOOP EAST  
 HOUSTON, TX 77029  
 Phone: 713-580-8122  
 E-Mail:  
 mmccarthy@strhouston.com

## DIMENSIONS

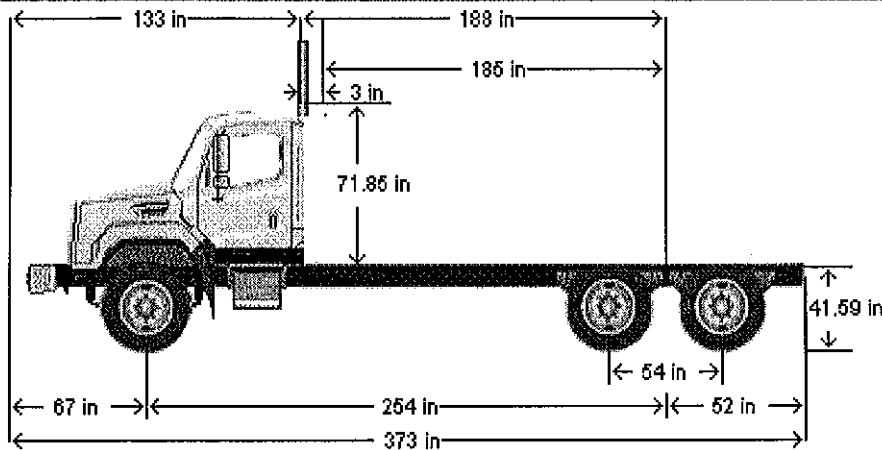

## VEHICLE SPECIFICATIONS SUMMARY - DIMENSIONS

Model .....	114SD
Wheelbase (545) .....	6450MM (254 INCH) WHEELBASE
Rear Frame Overhang (552) .....	1325MM (52 INCH) REAR FRAME OVERHANG
Fifth Wheel (578) .....	NO FIFTH WHEEL
Mounting Location (577) .....	NO FIFTH WHEEL LOCATION
Maximum Forward Position (in) .....	0
Maximum Rearward Position (in) .....	0
Amount of Slide Travel (in) .....	0
Slide Increment (in) .....	0
Desired Slide Position (in) .....	0.0
Cab Size (829) .....	114 INCH BBC FLAT ROOF ALUMINUM CONVENTIONAL CAB
Sleeper (682) .....	NO SLEEPER BOX/SLEEPERCAB
Exhaust System (016) .....	RH OUTBOARD UNDER STEP MOUNTED HORIZONTAL AFTERTREATMENT SYSTEM ASSEMBLY WITH RH B-PILLAR MOUNTED VERTICAL TAILPIPE





Prepared for:  
 Tomas Sanchez  
 Webb County Water Utility  
 1000 Houston St  
 Laredo, TX 78040  
 Phone: 956-523-5586

Prepared by:  
 Michael McCarthy  
 HOUSTON FREIGHTLINER,  
 WESTERN STAR  
 9550 NORTH LOOP EAST  
 HOUSTON, TX 77029  
 Phone: 713-580-8122  
 E-Mail:  
 mmccarthy@strhouston.com

**TABLE SUMMARY - DIMENSIONS**

Dimensions	Inches
Bumper to Back of Cab (BBC)	132.9
Bumper to Centerline of Front Axle (BA)	67.3
Min. Cab to Body Clearance (CB)	3.0
Back of Cab to Centerline of Rear Axle(s) (CA)	189.4
Effective Back of Cab to Centerline of Rear Axle(s) (Effective CA)	185.4
Back of Cab Protrusions (Exhaust/Intake) (CP)	1.5
Back of Cab Protrusions (Side Extenders/Trim Tab) (CP)	0.0
Back of Cab Clearance (CL)	3.0
Back of Cab to End of Frame	240.4
Cab Height (CH)	71.9
Wheelbase (WB)	254.0
Frame Overhang (OH)	52.0
Overall Length (OAL)	373.3
Rear Axle Spacing	54.0
Unladen Frame Height at Centerline of Rear Axle	41.6

Performance calculations are estimates only. If performance calculations are critical, please contact Customer Application Engineering.





Address: 17000 West Cleveland Avenue  
 City, State, Zip: New Berlin, WI 53151  
 Phone: 262-784-7100  
 Fax: 262-784-9861  
 Email:

Quote Number: 1056  
 Customer: Webb County Water Utility  
 Customer Contact: Tomas Sanchez  
 Customer Address: 515 Martha Dr.

Account Rep: Jeff Paterson

Quote Date: 8/15/2014

City: Rio Bravo  
 State: Texas  
 Zip: 78040  
 Phone: 956-523-5586  
 Email: tomsanchez@webbcountytx.gov

Quote is Valid until:

Part No.	Quantity	Description
		EJECTOR TYPE CAMEL 200 / 12 YD (9.2m) COMBINATION SEWER
8777	1	CLEANER
1877	1	8" vacuum system, "Roots type PD Model 824, 18" hg. and 4500 cfm
2391	1	Vacuum booster valve
2097	1	Pleated Final Filter Assembly
2231	1	6" diameter front body drain, knife valve, 35' x 6" fabric drain hose, camlock cap
1973	1	Rear splash shield
2210	1	80 GPM @ 2000 PSI
6727	1	Winter recirculation
2387	1	Retractable hose reel with live center with 50' x 1/2" hose
2383	1	Hydro Excavation Kit
2396	1	Low water warning light and alarm with water capacity digital display
2398	1	Wireless Remote
3665-60000	1	500' 1" hose
9050-00071	1	Manual level wind
5224	1	Hose reel digital counter
2401	1	LED Boom work lights
2403	1	50' Handlight - retractable reel
2404	1	LED Package 2 - (2) Tailgate beacon omni-directional strobe, (2) Boom beacon omni-directional strobe, Directional arrowstick
2392	1	Remote Grease Fitting Plumbing - Tailgate/Boom
2395	1	Lower Curbside Toolbox 18" x 18" x 48"
5822	1	Curbside Toolbox 18" x 18" x 48"
2393	1	Back of Cab vertical tube rack
2382	1	Front / Rear tow hooks
000XX	1	Urethane paint finish, unit only, white - paint number below Paint Number: White
6000-02065-8020	1	1" NPT Grenade Nozzles - 80GPM @ 2000PSI
6000-02011-8020	1	1" NPT Chisel Nozzles - 80GPM @ 2000PSI
9010-01150	1	Cleaning Lance (For Handgun) w/ Adjustable Nozzle & Handle
9050-00038-0002	1	1" standard nozzle extension
3500-00239	1	Hose, 25', cotton - Single Jacket Filler Hose
3736-12000-0016	1	Leader Hose 1" x 10'
3000-02601	1	Tigertail Sewer Hose Guide
3000-01242	1	Hydrant wrench
3000-01244	1	Puller hook
4510-00245	1	Fluidizing Suction Tube Nozzle 8" x 24"
8500-02842	1	Serrated Nozzle 8" diameter
3000-02948	1	Vacuum Tube 8" (F) x 6" (M) Reducer
3000-00824	1	Supertube Lock ring 6"
3000-00825	7	Supertube Lock ring 8"
8510-01373	2	8" x 36" Supertube - Aluminum
8510-01374	3	8" x 60" Supertube - Aluminum
8510-01375	2	8" x 84" Supertube - Aluminum
8510-00290	1	8" x 96" Supertube - Aluminum
	1	Customer Supplied - Chassis Approval Required Before Order
	1	CPE
FREIGHT	1	Freight Charges

Total: \$233,923.07