

A Proposal for Installation of Camera/Data Wiring installation for:

Webb County Jail, (Camera Installation)

Submitted By:

Audio Dynamics, Inc.

Automation * Entertainment*
Security* Cabling Group

President
Fermin Flores

(956) 337-1951

fermin@audiodynamicsinc.com

Audio Dynamics, Inc.
101W Hillside Rd., Ste 11B
Laredo, TX 78041
956-712-8249 Office
956-712-4436 Fax

fermin@audiodynamicsinc.com

www.audiodynamicsinc.com

Cabling Scope of Work

Statement Date: 12/29/22
Audio Dynamics, Inc. Bid No.: 0805

General Requirements

Audio Dynamics, Inc. will provide a structured cabling system outlined in this scope of work. This cabling system will include all labor and materials. This Scope of Work is based on the prints that were provided.

Audio Dynamics, Inc. Contacts:

Fermin Flores, Jr.
President
Email: fermin@audiodynamicsinc.com
Office: 956-712-8249
Fax: 956-712-4436
Cell: 956-337-1951

Cabling Requirements

Quality of Work

All work shall be in accordance with the respective drawings, written specifications, industry standards, trade practices, and applicable regulatory agencies. Audio Dynamics, Inc. will provide professional services to meet and exceed performance standards and industry recommendations that relate to the above scope of work.

Scope of work (Camera Installtion)

- Audio Dynamics will install 280 6mp IP cameras. HikVision Model indicated on proposal.
- Hik Vision NVR Storage will provide from 30-45 days of storage. Setup of storage will be done once all cameras are connected to system.
- Audio Dynamics will provide CAT6 indoor rated cable to each camera from MDF or IDF.
- Audio Dynamics will provide CAT6 outdoor rated cable for each outdoor camera through the PVC Conduit.
- Audio Dynamics will provide labor to remove the old cameras and wiring.

SCP Category 6 (CAT6) cables are manufactured and tested to exceed ANSI/TIA 568-C.2 and ISO/IEC 11801 Class E standards.

SCP CAT6 cables are primarily available in several construction configurations: UTP (unshielded twisted pair); F/UTP (shielded - overall foil shield); and Siamese (side by side). Cat6 cables also included in our Structured/Composite/Bundled cable series.

Certifications: UL CMP and CMR; ETL CMP and CMR; CPR Dca to B2ca; and HDBaseT.

- Audio Dynamics will provide Estimate for Solution 1: 9 32 Channel NVR Recorder w/16 Port POE Built-in. Will 9 16 Port POE Switches. This will give you a total of 288 Cameras

-Audio Dynamics will provide Estimate for Solution 2: 1 228 Channel NVR and 1 128 Channel NVR. With 12 24Port POE switches. This will give you a total of 356 Cameras. This solution will record at 30fps full resolution.

-Audio Dynamics will provide on each estimate of 4 Hikvision 270 Degree cameras to replace the outdoor PTZ cameras.

Labeling

Faceplates will have appropriate cable labeling which will correspond to labeling on patch panels in telecom room.

Cable Testing and Verification Requirements

Audio Dynamics, Inc. will test 100 % of all cables installed, furnished or terminated during delivery of this proposal.

All Audio Dynamics, Inc. Cabling installed cables will be tested and documented as testing progresses. Upon completion of the cable testing, any cables noted as failed will be repaired and re-tested.

Project Management

Audio Dynamics, Inc. will assign a project manager/Lead technician for the duration of the project. Changes may be required due to architectural constraints or customer requirements.

Terms and Conditions

Certain standard terms and conditions will govern all work performed under this scope of work.

Audio Dynamics, Inc. will:

Act in a highly professional manner with an emphasis on Customer Satisfaction.

Obtain all necessary permits and licenses.

Provide cleanup of all work areas and installation points used by Audio Dynamics, Inc.

Audio Dynamics, Inc. has bid this with the knowledge of working from 9AM to? (Monday through Friday)

Warranty

Standard Warranty

All materials and labor supplied by Audio Dynamics, Inc. are under warranty to be free from defects for a period of 12 months from the completion date of the installation.

HIKVISION

USA

RMA

POLICY

Document Purpose and Scope: This document addresses return policies applicable to the products that are purchased by authorized distributors of Hikvision USA and that are returned to Hikvision USA Inc. for repair or return.

Amending this Policy: Hikvision may choose to amend the Policy in part or its entirety at any time, without notice.

Hikvision's Responsibility: Hikvision's sole responsibility under the Hikvision warranty is limited to repairing or replacing the defective products returned by authorized distributors and direct purchasers. For details on the product warranty provided by Hikvision USA for the respective products, please refer to the following table.

PRODUCT CATEGORY

REPAIR WARRANTY PERIOD

(PARTS AND LABOR)

DVRs/Encoders	36 months
7 Series Value NVRs	36 months
9 Series Professional NVRs	60 months
CVRs	36 months
Value PTZ Cameras	36 months
Professional PTZs Cameras	60 months
TurboHD Cameras	36 months
Value IP Cameras	36 months
Professional IP Cameras	60 months (*Batteries in solar-powered camera setups are limited only)
Thermal Cameras (excludes HAT Thermal Cameras)	36 months
Value Express	60 months
Bundle (Kit) Packages	24 months
Compression Cards	36 months (separate sub-kit parts included)
Lenses and Accessories	36 months

RFP Pricing

Project timeline will be determined upon acceptance of this scope.

Project Pricing: Audio Dynamics, Inc. will provide all labor, materials and project management based upon the details outlined in this scope of work as follows:

Payment Terms

As Per Webb County

This quote is valid for a period of 60 days.

, We accept the terms and conditions as described in the Proposal and in Appendix A, incorporated herein by this reference, and authorize Audio Dynamics, Inc. to perform the work described in the Proposal. The Audio Dynamics, Inc. thanks you for the opportunity to provide a cabling infrastructure solution for you!

By: _____ Fermin Flores _____
Date: _____ 12/29/22 _____
Title: _____ Owner _____

A Proposal for Installation of Camera/Data Wiring installation for:

Webb County Jail, (Camera Installation)

Submitted By:

Audio Dynamics, Inc.

Automation * Entertainment*
Security* Cabling Group

President
Fermin Flores

(956) 337-1951

fermin@audiodynamicsinc.com

Audio Dynamics, Inc.
101W Hillside Rd., Ste 11B
Laredo, TX 78041
956-712-8249 Office
956-712-4436 Fax

fermin@audiodynamicsinc.com

www.audiodynamicsinc.com

Cablling Scope of Work

Statement Date: 12/29/22
Audio Dynamics, Inc. Bid No.: 0805

General Requirements

Audio Dynamics, Inc. will provide a structured cabling system outlined in this scope of work. This cabling system will include all labor and materials. This Scope of Work is based on the prints that were provided.

Audio Dynamics, Inc. Contacts:

Fermin Flores, Jr.
President
Email: fermin@audiodynamicsinc.com
Office: 956-712-8249
Fax: 956-712-4436
Cell: 956-337-1951

Cablling Requirements

Quality of Work

All work shall be in accordance with the respective drawings, written specifications, industry standards, trade practices, and applicable regulatory agencies. Audio Dynamics, Inc. will provide professional services to meet and exceed performance standards and industry recommendations that relate to the above scope of work.

Scope of work (Camera Installtion)

- Audio Dynamics will install 280 6mp IP cameras. HikVision Model indicated on proposal.
- Hik Vision NVR Storage will provide from 30-45 days of storage. Setup of storage will be done once all cameras are connected to system.
- Audio Dynamics will provide CAT6 indoor rated cable to each camera from MDF or IDF.
- Audio Dynamics will provide CAT6 outdoor rated cable for each outdoor camera through the PVC Conduit.
- Audio Dynamics will provide labor to remove the old cameras and wiring.

SCP Category 6 (CAT6) cables are manufactured and tested to exceed ANSI/TIA 568-C.2 and ISO/IEC 11801 Class E standards.

SCP CAT6 cables are primarily available in several construction configurations: UTP (unshielded twisted pair); F/UTP (shielded - overall foil shield); and Siamese (side by side). Cat6 cables also included in our Structured/Composite/Bundled cable series.

Certifications: UL CMP and CMR; ETL CMP and CMR; CPR Dca to B2ca; and HDBaseT.

- Audio Dynamics will provide Estimate for Solution 1: 9 32 Channel NVR Recorder w/16 Port POE Built-in. Will 9 16 Port POE Switches. This will give you a total of 288 Cameras

-Audio Dynamics will provide Estimate for Solution 2: 1 228 Channel NVR and 1 128 Channel NVR. With 12 24Port POE switches. This will give you a total of 356 Cameras. This solution will record at 30fps full resolution.

-Audio Dynamics will provide on each estimate of 4 Hikvision 270 Degree cameras to replace the outdoor PTZ cameras.

Labeling

Faceplates will have appropriate cable labeling which will correspond to labeling on patch panels in telecom room.

Cable Testing and Verification Requirements

Audio Dynamics, Inc. will test 100 % of all cables installed, furnished or terminated during delivery of this proposal.

All Audio Dynamics, Inc. Cabling installed cables will be tested and documented as testing progresses. Upon completion of the cable testing, any cables noted as failed will be repaired and re-tested.

Project Management

Audio Dynamics, Inc. will assign a project manager/Lead technician for the duration of the project. Changes may be required due to architectural constraints or customer requirements.

Terms and Conditions

Certain standard terms and conditions will govern all work performed under this scope of work.

Audio Dynamics, Inc. will:

Act in a highly professional manner with an emphasis on Customer Satisfaction.

Obtain all necessary permits and licenses.

Provide cleanup of all work areas and installation points used by Audio Dynamics, Inc.

Audio Dynamics, Inc. has bid this with the knowledge of working from 9AM to? (Monday through Friday)

Warranty

Standard Warranty

All materials and labor supplied by Audio Dynamics, Inc. are under warranty to be free from defects for a period of 12 months from the completion date of the installation.

HIKVISION

USA

RMA

POLICY

Document Purpose and Scope: This document addresses return policies applicable to the products that are purchased by authorized distributors of Hikvision USA and that are returned to Hikvision USA Inc. for repair or return.

Amending this Policy: Hikvision may choose to amend the Policy, in part or its entirety, at any time, without notice.

Hikvision's Responsibility: Hikvision's sole responsibility under the Hikvision warranty is limited to repairing or replacing the defective products returned by authorized distributors and direct purchasers. For details on the product warranty provided by Hikvision USA for the respective products, please refer to the following table.

PRODUCT CATEGORY

REPAIR WARRANTY PERIOD

	(PARTS AND LABOR)
DVRs/Encoders	36 months
7 Series Value NVRs	36 months
9 Series Professional NVRs	60 months
CVRs	36 months
Value PTZ Cameras	36 months
Professional PTZs Cameras	60 months
TurboHD Cameras	36 months
Value IP Cameras	36 months
Professional IP Cameras	60 months (*Batteries in solar-powered camera setups are limited only)
Thermal Cameras (excludes HAT Thermal Cameras)	36 months
Thermal Cameras (excludes HAT Thermal Cameras)	60 months
Value Express	24 months
Bundle (Kit) Packages	36 months (separate sub-kit parts included)
Compression Cards	36 months
Lenses and Accessories	36 months

RFP Pricing

Project timeline will be determined upon acceptance of this scope.

Project Pricing: Audio Dynamics, Inc. will provide all labor, materials and project management based upon the details outlined in this scope of work as follows:

Payment Terms

As Per Webb County

This quote is valid for a period of 30 days.

, We accept the terms and conditions as described in the Proposal and in Appendix A, incorporated herein by this reference, and authorize Audio Dynamics, Inc. to perform the work described in the Proposal. The Audio Dynamics, Inc. thanks you for the opportunity to provide a cabling infrastructure solution for you!

By: _____ Fermin Flores _____

Date: _____ 12/29/22 _____

Title: _____ Owner _____

A Proposal for Installation of Data Wiring installation for:

Webb County RFP 2023-001 Jail Security
Camera Upgrade Project, **(Camera
Installation and Wiring)**

Submitted By:

Audio Dynamics, Inc.

Automation * Entertainment*
Security* Cabling Group

President
Fermin Flores

(956) 337-1951

fermin@audiodynamicsinc.com

Audio Dynamics, Inc.
101W Hillside Rd., Ste 11B
Laredo, TX 78041
956-712-8249 Office
956-712-4436 Fax
audiodynamics@stx.rr.com
www.audiodynamicsinc.com

Cabling Scope of Work

Statement Date: 11/22/22
Audio Dynamics, Inc. Bid No.: 1122

General Requirements

Audio Dynamics, Inc. will provide a structured cabling system outlined in this scope of work. This cabling system will include all labor and materials. This Scope of Work is based on the prints that were provided.

Audio Dynamics, Inc. Contacts:

Fermin Flores, Jr.
President
Email: fermin@audiodynamicsinc.com
Office: 956-712-8249
Fax: 956-712-4436
Cell: 956-337-1951

Cabling Requirements

Quality of Work

All work shall be in accordance with the respective drawings, written specifications, industry standards, trade practices, and applicable regulatory agencies. Audio Dynamics, Inc. will provide professional services to meet and exceed performance standards and industry recommendations that relate to the above scope of work.

Scope of work

Scope of Work Requirements: Audio Dynamics will provide 280 IP POE fixed cameras 5MP minimum (120 - 160 Degree FOV) preferred } 9 NVRs with sufficient storage for a 35-day minimum playback } VMS program with analytics } Removal of all existing camera equipment } All cabling/installation must meet jail safety standards (conduit) 24 turnaround time for service calls on weekends and no later than next business day for Monday – Friday during the warranty period.. } Warranty on parts and labor 2 year minimum

Audio Dynamics will provide services, products and installation for a “turn-key” security camera system to include software, hardware, removal of existing security camera system, disposal and installation of all necessary components.

Labeling

Faceplates will have appropriate cable labeling which will correspond to labeling on patch panels in telecom room.

Cable Testing and Verification Requirements

Audio Dynamics, Inc. will test 100 % of all cables installed, furnished or terminated during delivery of this proposal.

All Audio Dynamics, Inc. Cabling installed cables will be tested and documented as testing progresses. Upon completion of the cable testing, any cables noted as failed will be repaired and re-tested.

Project Management

Audio Dynamics, Inc. will assign a project manager/Lead technician for the duration of the project. Changes may be required due to architectural constraints or customer requirements.

Terms and Conditions

Certain standard terms and conditions will govern all work performed under this scope of work. Audio Dynamics, Inc. will:
Act in a highly professional manner with an emphasis on Customer Satisfaction.
Obtain all necessary permits and licenses.
Provide cleanup of all work areas and installation points used by Audio Dynamics, Inc.
Audio Dynamics, Inc. has bid this with the knowledge of working from 9AM to? (Monday through Friday)

Warranty

Standard Warranty

All materials and labor supplied by Audio Dynamics, Inc. are under warranty to be free from defects for a period of 24 months from the completion date of the installation.

RFP Pricing

Project timeline will be determined upon acceptance of this scope.

Project Pricing: Audio Dynamics, Inc. will provide all labor, materials and project management based upon the details outlined in this scope of work as follows:

This quote is valid for a period of 30 days.

, We accept the terms and conditions as described in the Proposal and in Appendix A, incorporated herein by this reference, and authorize Audio Dynamics, Inc. to perform the work described in the Proposal. The Audio Dynamics, Inc. thanks you for the opportunity to provide a cabling infrastructure solution for you!

By: _____ Fermin Flores

Date: _____ 11/22/22

Title: _____ Owner



101 W. Hillside Rd., Ste 11B
 Laredo, TX 78041
 (956)712-8249 Office (956)712-4436 Fax

Estimate

Number: E4094

Date: 11/23/2022

Bill To:

Webb County

Ship To:

--

Terms	Customer #	Service Rep.	Project
			Solution 1

Description	Qty/Hz	Price/Ra T	Amount
XR-432 : 32 Channels NVR Performance Series / H.265+ / 16 PoE+ Ports / up to 12 MP recording resolution / 4 HDD Slots / Supports POS	9.00	\$680.00	\$6,120.00
WI-PS518G : Long-Range PoE (802.3af/at/bt) Switch unmanageable with 16 x 10/100Tx (PoE), 2 x 100/1000Tx and 1 x SFP, 200W	9.00	\$185.00	\$1,665.00
XT26S : 6 Megapixel IP Turret / PRO Series / 30 mts IR EXIR / Exterior IP66 / WDR 120 dB / PoE / 2.8 mm Lens / Integrated Video Analytics / Integrated Microphone	280.00	\$190.00	\$53,200.00
DS-1280ZJ-XS-AX : Metal Junction Box for DS-2CD20**, B8**, E8**, LE7**, LB7**	200.00	\$16.99	\$3,398.00
WD84PURZ : WD HDD 8TB / Optimized for Video Surveillance / 5640RPM	36.00	\$299.00	\$10,764.00
Install Camera (Mount, Adjust, and Cable) Cat6 Cable. Includes removal of old camera and wire	280.00	\$150.00	\$42,000.00
Cat6 Cable Wire 1000ft Spools	20.00	\$30.00	\$600.00
Conduit and Misc. Parts, J-hooks, Labels	1.00	\$450.00	\$450.00
OmniMount RE42 Rack System Enclosed w/casters and locking glass door	1.00	\$1,500.00	\$1,500.00
2 years labor warranty by vendor-in the event a camera is damaged, vendor will provide a temporary loaner while damaged camera is sent out to factory for repair. Electrical Surges are not covered under warranty.		\$0.00	\$0.00



101 W. Hillside Rd., Ste 11B
 Laredo, TX 78041
 (956)712-8249 Office (956)712-4436 Fax

Estimate

Number: E4094

Date: 11/23/2022

Bill To:

Webb County

Ship To:

Terms	Customer #	Service Rep.	Project
			Solution 1

Description	Qty/Hz	Price/Ra T	Amount
Warranty from manufacture for 3 Years		\$0.00	\$0.00
Warranty (Covers Labor) For Two Years		\$0.00	\$0.00
Option: PTZ Replacement for 270 degree cameras			
Hikvision DS-2CD6D54G1-IZS 20MP Outdoor Multi-Sensor PanoVu EXIR Flexible Network Camera, 2.8-8mm Motorized Varifocal Lens, Includes Wall Mount Adapters	4.00	\$1,850.00	\$7,400.00
Install Camera (Mount, Adjust, and Cable) Cat6 Cable	4.00	\$155.00	\$620.00

Amount Paid	\$0.00	Discount	\$0.00
Amount Due	\$127,717.00		
		SubTotal	\$127,717.00
		State Tax 8.25% on \$0.00	\$0.00
		Total	\$127,717.00

DS-2CD6D54G1-IZS

PanoVu EXIR Flexible Network Camera



Hikvision's DS-2CD6D54G1-IZS EXIR PanoVu Flexible Outdoor Network Camera features 1/2.7" progressive scan CMOS sensors and four lenses. Each lens supports a resolution of up to 2560 x 1920 at 24 fps. Compression up to H.265+ saves bandwidth and storage space. EXIR technology extends the IR range to 100 feet (30 meters).

Available Models

DS-2CD6D54G1-IZS

- 1/2.7" Progressive Scan CMOS
- 2560 x 1920 @ 24 fps
- Four Flexible Lenses
- FOV: Horizontal 100° to 49°, Vertical 72° to 36.4°, Diagonal 134.4° to 61.4°
- H.265+, H.265, H.264+, H.264
- 120 dB WDR
- 6 Behavior Analyses, 4 Exception Detections, and Face Detection
- 100 ft (30 m) IR Range
- IP67, IK10
- 4 x 2-Axis Individual Camera Gimbals



Specifications

DS-2CD6D5461-IZS		
Camera		
Image Sensor	1/2.7" progressive scan CMOS	
Minimum Illumination	Color: 0.0125 lux @ (f/1.9, AGC on), B/W: 0.0025 lux @ (f/1.9, AGC on)	
Shutter Speed	1 s to 1/100,000 s	
Slow Shutter	Yes	
Day/Night	IR cut filter	
WDR	120 dB	
Adjustment	Pan: -60° to 60°, tilt: 10° to 90°	
Lens		
Focal Length	2.8 mm to 8 mm motorized varifocal lens	
Aperture	f/1.9	
Focus	Manual, semi-automatic	
FOV	Horizontal field of view: 100° to 49° Vertical field of view: 72° to 36.4° Diagonal field of view: 134.4° to 61.4°	
Lens Mount	Ø14	
IR		
IR Range	Up to 100 ft (30 m)	
Wavelength	850 nm	
DORI² (Detect, Observe, Recognize, Identify)		
Detect Distance	Wide	197 ft (60 m)
	Tele	394 ft (120 m)
Observe Distance	Wide	75 ft (23 m)
	Tele	154 ft (47 m)
Recognize Distance	Wide	39 ft (12 m)
	Tele	79 ft (24 m)
Identify Distance	Wide	20 ft (6 m)
	Tele	39 ft (12 m)
Video²		
Maximum Resolution	2560 x 1920	
Video Streams	Three defined streams	
Main Stream	24 fps (2560 × 1920, 2048 × 1536, 1920 × 1080, 1280 × 720)	
Sub Stream	24 fps (704 × 480, 640 × 480)	
Third Stream	8 fps (1920 × 1080, 1280 × 720, 704 × 480, 640 × 480)	
Video Compression	Main stream: H.265+/H.265/H.264+/H.264 Sub stream: H.265/H.264/MJPEG Third stream: H.265/H.264	
H.264 Type	Baseline profile/main profile/high profile	
H.264+	Main stream supported	
H.265 Type	Main profile	
H.265+	Main stream supported	
Video Bit Rate	32 Kbps to 16 Mbps	
SVC	H.264 encoding	
Audio		
Audio Compression	G.711/G.722.1/G.726/MP2L2/PCM	
Audio Bit Rate	64 Kbps (G.711)/16 Kbps (G.722.1)/16 Kbps (G.726)/32 to 160 Kbps (MP2L2)/32 Kbps (PCM)	
Environment Noise Filtering	Yes	
Audio Sampling Rate	8 kHz/16 kHz/32 kHz/44.1 kHz/48 kHz	
Smart Features³		
Smart Event	<ul style="list-style-type: none"> Line crossing detection (up to 4 lines configurable) Intrusion detection, region entrance detection, region exiting detection, unattended baggage detection, object removal detection (up to 4 regions configurable) Scene change detection, audio exception detection, defocus detection 	
Basic Event	Motion detection, video tampering alarm, exception (network disconnected, IP address conflict, illegal login, HDD full, HDD error)	
Linkage Method	Upload to FTP/NAS/memory card, notify surveillance center, send e-mail, trigger alarm output, trigger recording, trigger capture	
Region of Interest	Four fixed regions and dynamic face tracking for each system	
Image		
Image Enhancement	BLC, HLC, 3D DNR, Defog, EIS	
Image Setting	Rotate mode, saturation, brightness, contrast, sharpness, AGC and white balance are adjustable by client software or Web browser	
Target Cropping	Yes	
Day/Night Switch	Day/night/auto/schedule/triggered by alarm in	
Picture Overlay	Logo picture can be overlaid on video with 128 × 128 24-bit bmp format	
SNR	≥52 dB	

¹ DORI: The DORI (detect, observe, recognize, identify) distance gives the general idea of the camera ability to distinguish persons or objects within its field of view. It is calculated based on the camera sensor specification and the criteria given by EN 62676-4: 2015.

² Listed resolutions are only selectable options. It does not mean that all streams can work at their maximum resolution at the same time.

³ Smart Events and Dynamic Face Tracking are limited to 2 channels at a time (channels 1 and 3 or 2 and 4).

Specifications (continued)

Network	
Network Storage	Supports microSD/SDHC/SDXC card (128 GB), local storage and NAS (NFS, SMB/CIFS), ANR
Protocols	TCP/IP, ICMP, HTTP, HTTPS, FTP, DHCP, DNS, DDNS, RTP, RTSP, RTCP, PPPoE, NTP, UPnP, SMTP, SNMP, IGMP, 802.1x, QoS, IPv6, UDP, Bonjour
API	ONVIF (PROFILE S, PROFILE G, PROFILE T), ISAPI, SDK, Ehome
Security	Password protection, complicated password, HTTPS encryption, 802.1x authentication (EAP-MD5), watermark, IP address filter, basic and digest authentication for HTTP/HTTPS, WSSE and digest authentication for ONVIF
Simultaneous Live View	Up to 20 channels
User/Host	Up to 32 users, 3 levels: Administrator, Operator, and User
Client	iVMS-4200, Hik-Connect, HikCentral
Web Browser	IE 8+, Chrome 41.0-44, Firefox 30.0-51, Safari 8.0-11
Interface	
Audio	1-ch 3.5 mm input (line in), 1-ch 3.5 mm output, mono sound
Communication Interface	1 RJ-45 10M/100M/1000M Ethernet port, built-in RS-232 1 RS-485 interface (half duplex, HIKVISION, Pelco-P, Pelco-D, self-adaptive)
Alarm	2 inputs, 2 outputs (maximum 24 VDC, 1A)
On-Board Storage	Built-in microSD/SDHC/SDXC slot, up to 128 GB
General	
General Function	Anti-flicker, three streams, heartbeat, mirror, privacy masks
Reset	Reset button on camera body, Web browser, and client software
Startup and Operating Conditions	-22° to 140° F (-30° to 60° C), humidity 95% or less (non-condensing)
Storage Conditions	-22° to 140° F (-30° to 60° C), humidity 95% or less (non-condensing)
Power Supply	12 VDC ±20%, reverse polarity protection, three-core terminal block; 24 VAC ±20%, PoE (802.3at, class 4)
Power Consumption and Current	12 VDC, 1.8 A, 22 W; 24 VAC, 1.4 A, 22 W; PoE (802.3at, 42.5 to 57 VDC), 0.44 to 0.33 A, 19 W, class 4
Protection	IP67 and IK10
Material	Bubble and IR cover: plastic; camera: metal
Dimensions	Camera: Ø9.8" × 4.4" (Ø250 mm × 113 mm) Package: 13.2" × 10.3" × 11.5" (336 mm × 261 mm × 293 mm)
Weight	Camera: 4.7 lbs (2.13 kg) With Package: 8.6 lb (3.9 kg)
Approvals	
EMC	47 CFR Part 15, Subpart B; EN 55032: 2015, EN 61000-3-2: 2014, EN 61000-3-3: 2013, EN 50130-4: 2011 +A1: 2014; AS/NZS CISPR 32: 2015; ICES-003: Issue 6, 2016; KN 32: 2015, KN 35: 2015
Safety	UL 60950-1, IEC 60950-1:2005 + Am 1:2009 + Am 2:2013, EN 60950-1:2005 + Am 1:2009 + Am 2:2013, IS 13252 (Part 1):2010 + A1:2013 + A2:2015
Chemistry	2011/65/EU, 2012/19/EU, Regulation (EC) No 1907/2006
Protection	Ingress protection: IK10 (IEC 62262:2002), IP67 (IEC 60529-2013)

Dimensions

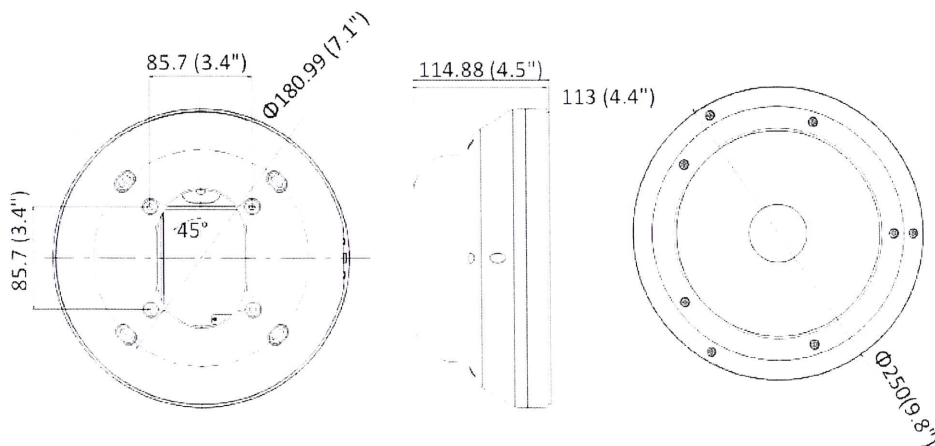

Units: mm (inches)

Accessories (Not Included)

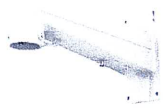

WMP-L
Wall Mount



WMP-PV
Wall Mount

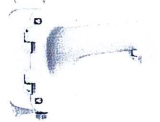

JBPW-L
Wall Mount



PMP
Vertical Pole Mount



CMP
Corner Mount



CPM-S
Pendant Mount



PC-G1
Pendant Cap



CMP-JB
Corner Mount



PMP-JB
Pole Mount

Box Contents (Subject to Change without Notice)

Quick Start Guide
Screws
Watertight Cable Connector
Waterproof Tape x 5
Wall Anchors
Wrench
Cleaning Cloth

County of Webb

ADDENDUM No. 1 TO THE RFP DOCUMENTS
Addendum Date: November 23, 2022

RFP DOCUMENT NUMBER RFP 2023-001
“Jail Security Camera Upgrade Project”

A. This Addendum shall be considered part of the RFP documents for the above-mentioned project as though it had been issued at the same time and shall be incorporated integrally therewith. Where provisions of the following supplementary data differ from those of the original bid documents, this Addendum shall govern and take precedence. **RESPONDENTS MUST SIGN THE ADDENDUM AND SUBMIT IT WITH THEIR BIDS/PROPOSALS.**

B. Respondent are hereby notified that they shall make any necessary adjustments in their estimates as a result of this Addendum. It will be construed that each bidder's proposal is submitted with full knowledge of all modifications and supplemental data specified herein.

Except as described below, the original RFP document remains unchanged. The RFP documents are modified and/or clarified, as follows:

- **The deadline for questions has been corrected on the Webb County eBid portal from December 8, 2022 to Monday November 28, 2022 at 5pm.**

**RESPONDENT MUST ACKNOWLEDGE THIS ADDENDUM BY
SIGNING BELOW AND ATTACHING THE SIGNED ADDENDUM TO
THE PROPOSAL FORM(S):**

Company Name Audio Dynamics

Contact Person Fernan Flores

Signature 

Date 11/23/22

THIS CONCLUDES ADDENDUM NO. 1 IN ITS ENTIRETY.

This Addendum is being transmitted electronically via our E-Bid site @ <https://webbcountyebid.ionwave.net/Login.aspx> . If you have any questions, please direct them to; Juan Guerrero Jr. (956) 523-4149 or email at juguerrero@webbcountytx.gov .

County of Webb

ADDENDUM No. 2 TO THE RFP DOCUMENTS

Addendum Date: November 23, 2022

RFP DOCUMENT NUMBER RFP 2023-001

“Jail Security Camera Upgrade Project”

A. This Addendum shall be considered part of the RFP documents for the above-mentioned project as though it had been issued at the same time and shall be incorporated integrally therewith. Where provisions of the following supplementary data differ from those of the original bid documents, this Addendum shall govern and take precedence. **RESPONDENTS MUST SIGN THE ADDENDUM AND SUBMIT IT WITH THEIR BIDS/PROPOSALS.**

B. Respondent are hereby notified that they shall make any necessary adjustments in their estimates as a result of this Addendum. It will be construed that each bidder's proposal is submitted with full knowledge of all modifications and supplemental data specified herein.

Except as described below, the original RFP document remains unchanged. The RFP documents are modified and/or clarified, as follows:

- **The deadline for questions has been corrected on the Webb County eBid portal from November 28, 2022 to Wednesday November 30, 2022 at 5pm.**

**RESPONDENT MUST ACKNOWLEDGE THIS ADDENDUM BY
SIGNING BELOW AND ATTACHING THE SIGNED ADDENDUM TO
THE PROPOSAL FORM(S):**

Company Name Audio Dynamics

Contact Person Fernan Flores

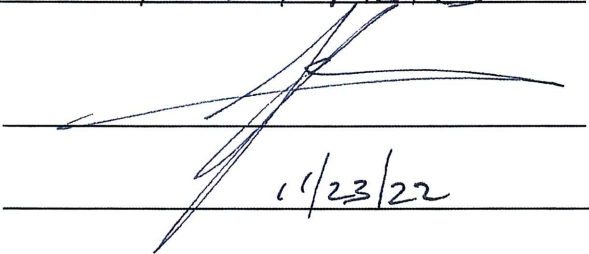
Signature 

Date 11/23/22

THIS CONCLUDES ADDENDUM NO. 1 IN ITS ENTIRETY.

This Addendum is being transmitted electronically via our E-Bid site @
<https://webbcountyebid.ionwave.net/Login.aspx> . If you have any questions, please direct them
to; Juan Guerrero Jr. (956) 523-4149 or email at juguerrero@webbcountytexas.gov .

County of Webb

ADDENDUM No. 3 TO THE RFP DOCUMENTS

Addendum Date: November 23, 2022

RFP DOCUMENT NUMBER RFP 2023-001

“Jail Security Camera Upgrade Project”

A. This Addendum shall be considered part of the RFP documents for the above-mentioned project as though it had been issued at the same time and shall be incorporated integrally therewith. Where provisions of the following supplementary data differ from those of the original bid documents, this Addendum shall govern and take precedence. **RESPONDENTS MUST SIGN THE ADDENDUM AND SUBMIT IT WITH THEIR BIDS/PROPOSALS.**

B. Respondent are hereby notified that they shall make any necessary adjustments in their estimates as a result of this Addendum. It will be construed that each bidder's proposal is submitted with full knowledge of all modifications and supplemental data specified herein.

Except as described below, the original RFP document remains unchanged. The RFP documents are modified and/or clarified, as follows:

- **The pre-proposal sign in sheet has been added under the Attachments tab.**
- **Drawings and pictures have been added under the Attachments tab.**

**RESPONDENT MUST ACKNOWLEDGE THIS ADDENDUM BY
SIGNING BELOW AND ATTACHING THE SIGNED ADDENDUM TO
THE PROPOSAL FORM(S):**

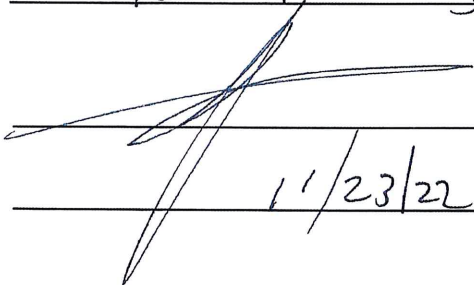
Company Name Audio Dynamics
Contact Person Felton Flores
Signature 
Date 11/23/22

THIS CONCLUDES ADDENDUM NO. 1 IN ITS ENTIRETY.

This Addendum is being transmitted electronically via our E-Bid site @
<https://webbcountyebid.ionwave.net/Login.aspx>. If you have any questions, please direct them
to; Juan Guerrero Jr. (956) 523-4149 or email at juguerrero@webbcountytx.gov.

County of Webb

ADDENDUM No. 4 TO THE RFP DOCUMENTS
Addendum Date: December 2, 2022

RFP DOCUMENT NUMBER RFP 2023-001
“Jail Security Camera Upgrade Project”

A. This Addendum shall be considered part of the RFP documents for the above-mentioned project as though it had been issued at the same time and shall be incorporated integrally therewith. Where provisions of the following supplementary data differ from those of the original bid documents, this Addendum shall govern and take precedence. **RESPONDENTS MUST SIGN THE ADDENDUM AND SUBMIT IT WITH THEIR BIDS/PROPOSALS.**

B. Respondent are hereby notified that they shall make any necessary adjustments in their estimates as a result of this Addendum. It will be construed that each bidder's proposal is submitted with full knowledge of all modifications and supplemental data specified herein.

Except as described below, the original RFP document remains unchanged. The RFP documents are modified and/or clarified, as follows:

- **The deadline to submit proposals has been extended from December 8, 2022 to Thursday December 22, 2022 at 10 am.**

RESPONDENT MUST ACKNOWLEDGE THIS ADDENDUM BY SIGNING BELOW AND ATTACHING THE SIGNED ADDENDUM TO THE PROPOSAL FORM(S):

Company Name Audio Dynamics

Contact Person Fernan Flores

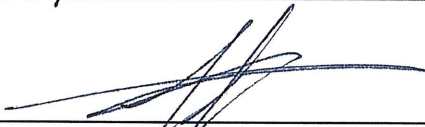
Signature 

Date 12/2/22

THIS CONCLUDES ADDENDUM NO. 4 IN ITS ENTIRETY.

This Addendum is being transmitted electronically via our E-Bid site @ <https://webbcountyebid.ionwave.net/Login.aspx> . If you have any questions, please direct them to; Juan Guerrero Jr. (956) 523-4149 or email at juguerrero@webbcountytx.gov .

County of Webb

ADDENDUM No. 5 TO THE RFP DOCUMENTS

Addendum Date: December 15, 2022

RFP DOCUMENT NUMBER RFP 2023-001

“Jail Security Camera Upgrade Project”

A. This Addendum shall be considered part of the RFP documents for the above-mentioned project as though it had been issued at the same time and shall be incorporated integrally therewith. Where provisions of the following supplementary data differ from those of the original bid documents, this Addendum shall govern and take precedence. **RESPONDENTS MUST SIGN THE ADDENDUM AND SUBMIT IT WITH THEIR BIDS/PROPOSALS.**

B. Respondent are hereby notified that they shall make any necessary adjustments in their estimates as a result of this Addendum. It will be construed that each bidder's proposal is submitted with full knowledge of all modifications and supplemental data specified herein.

Except as described below, the original RFP document remains unchanged. The RFP documents are modified and/or clarified, as follows:

- **The deadline to submit proposals has been extended from December 22, 2022 to Friday January 6, 2023 at 10 am.**
- **A walkthrough has been scheduled for Monday December 19. Please call Juan Guerrero at (956) 523-4149 or Cesar Guerra at (956) 523-4125 to schedule. The times available are 9 am, 11 am, 2 pm, 3 pm. Only 2 representatives per company are permitted. Background checks will be done for attendees. Scheduling will be done on a first call, first serve basis.**

**Location: Webb County Jail
1001 Washington St.
Laredo, TX 78040**

**RESPONDENT MUST ACKNOWLEDGE THIS ADDENDUM BY
SIGNING BELOW AND ATTACHING THE SIGNED ADDENDUM TO
THE PROPOSAL FORM(S):**

Company Name Audio Dynamics

Contact Person Fernan Flores

Signature 

Date 12/19/22

THIS CONCLUDES ADDENDUM NO. 5 IN ITS ENTIRETY.

This Addendum is being transmitted electronically via our E-Bid site @ <https://webbcountyebid.ionwave.net/Login.aspx>. If you have any questions, please direct them to; Juan Guerrero Jr. (956) 523-4149 or email at juguerrero@webbcountytexas.gov.

CERTIFICATION REGARDING FEDERAL LOBBYING
(Certification for Contracts, Grants, Loans, and Cooperative Agreements)

PART A. PREAMBLE

Federal legislation, Section 319 of Public Law 101-121 generally prohibits entities from using federally appropriated funds to lobby the executive or legislative branches of the federal government. Section 319 specifically requires disclosure of certain lobbying activities. A federal government-wide rule, "New Restrictions on Lobbying", published in the Federal Register, February 26, 1990, requires certification and disclosure in specific instances.

PART B. CERTIFICATION

This certification applies only to the instant federal action for which the certification is being obtained and is a material representation of fact upon which reliance was placed when this transaction was made or entered into. Submission of this certification is a prerequisite for making or entering into this transaction imposed by section 1352, title 31, U.S. Code. Any person who fails to file the required certification shall be subject to a civil penalty of not less than \$100,000 for each such failure.

The undersigned certifies, to the best of his or her knowledge and belief, that:

1. No federally appropriated funds have been paid or will be paid, by or on behalf of the undersigned, to any person for influencing or attempting to influence an officer or employee of any agency, a member of Congress, an officer or employee of Congress, or an employee of a member of Congress in connection with the awarding of any federal contract, the making of any federal grant, the making of any federal loan, the entering into of any cooperative agreement, or the extension, continuation, renewal, amendment, or modification of any federal contract, grant, loan, or cooperative agreement.
2. If any funds other than federally appropriated funds have been paid or will be paid to any person for influencing or attempting to influence an officer or employee of any agency, a member of Congress, an officer or employee of Congress, or an employee of a member of Congress in connection with these federally funded contract, subcontract, subgrant, or cooperative agreement, the undersigned shall complete and submit Standard Form-LLL, "Disclosure Form to Report Lobbying", in accordance with its instructions. (If needed, contact the Texas Department of Agriculture to obtain a copy of Standard Form-LLL.)

3. The undersigned shall require that the language of this certification be included in the award documents for all covered subawards at all tiers (including subcontracts, subgrants, and contracts under grants, loans, and cooperative agreements) and that all covered subrecipients will certify and disclose accordingly.

Do you have or do you anticipate having covered subawards under this transaction?

- Yes
- No

Name of Contractor/Potential Contractor	Vendor ID No. or Social Security No.	Program No.

Name of Authorized Representative	Title
FERNAN FLORES	PIES

Signature – Authorized Representative

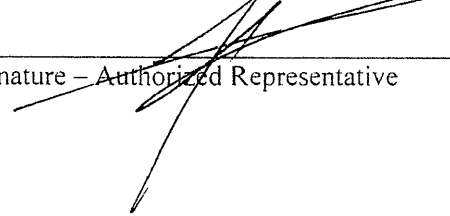

Date

11/23/22

CERTIFICATION
REGARDING DEBARMENT, SUSPENSION, INELIGIBILITY AND VOLUNTARY
EXCLUSION FOR COVERED CONTRACTS

PART A.

Federal Executive Orders 12549 and 12689 require the Texas Department of Agriculture (TDA) to screen each covered potential contractor to determine whether each has a right to obtain a contract in accordance with federal regulations on debarment, suspension, ineligibility, and voluntary exclusion. Each covered contractor must also screen each of its covered subcontractors.

In this certification "contractor" refers to both contractor and subcontractor; "contract" refers to both contract and subcontract.

By signing and submitting this certification the potential contractor accepts the following terms:

1. The certification herein below is a material representation of fact upon which reliance was placed when this contract was entered into. If it is later determined that the potential contractor knowingly rendered an erroneous certification, in addition to other remedies available to the federal government, the Department of Health and Human Services, United States Department of Agriculture or other federal department or agency, or the TDA may pursue available remedies, including suspension and/or debarment.
2. The potential contractor will provide immediate written notice to the person to which this certification is submitted if at any time the potential contractor learns that the certification was erroneous when submitted or has become erroneous by reason of changed circumstances.
3. The words "covered contract", "debarred", "suspended", "ineligible", "participant", "person", "principal", "proposal", and "voluntarily excluded", as used in this certification have meanings based upon materials in the Definitions and Coverage sections of federal rules implementing Executive Order 12549. Usage is as defined in the attachment.
4. The potential contractor agrees by submitting this certification that, should the proposed covered contract be entered into, it will not knowingly enter into any subcontract with a person who is debarred, suspended, declared ineligible, or voluntarily excluded from participation in this covered transaction, unless authorized by the Department of Health and Human Services, United States Department of Agriculture or other federal department or agency, and/or the TDA, as applicable.

Do you have or do you anticipate having subcontractors under this proposed contract?

Yes

No

5. The potential contractor further agrees by submitting this certification that it will include this certification titled "Certification Regarding Debarment, Suspension, Ineligibility, and Voluntary Exclusion for Covered Contracts" without modification, in all covered subcontracts and in solicitations for all covered subcontracts.
6. A contractor may rely upon a certification of a potential subcontractor that it is not debarred, suspended, ineligible, or voluntarily excluded from the covered contract, unless it knows that the certification is erroneous. A contractor must, at a minimum, obtain certifications from its covered subcontractors upon each subcontract's initiation and upon each renewal.
7. Nothing contained in all the foregoing will be construed to require establishment of a system of records in order to render in good faith the certification required by this certification document. The knowledge and information of a contractor is not required to exceed that which is normally possessed by a prudent person in the ordinary course of business dealings.
8. Except for contracts authorized under paragraph 4 of these terms, if a contractor in a covered contract knowingly enters into a covered subcontract with a person who is suspended, debarred, ineligible, or voluntarily excluded from participation in this transaction, in addition to other remedies available to the federal government, Department of Health and Human Services, United States Department of Agriculture, or other federal department or agency, as applicable, and/or the TDA may pursue available remedies, including suspension and/or debarment.

PART B. CERTIFICATION REGARDING DEBARMENT, SUSPENSION, INELIGIBILITY AND VOLUNTARY EXCLUSION FOR COVERED CONTRACTS

Indicate in the appropriate box which statement applies to the covered potential contractor:

- The potential contractor certifies, by submission of this certification, that neither it nor its principals is presently debarred, suspended, proposed for debarment, declared ineligible, or voluntarily excluded from participation in this contract by any federal department or agency or by the State of Texas.
- The potential contractor is unable to certify to one or more of the terms in this certification. In this instance, the potential contractor must attach an explanation for each of the above terms to which he is unable to make certification. Attach the explanation(s) to this certification.

Name of Contractor	Vendor ID No. or Social Security No.	Program No.

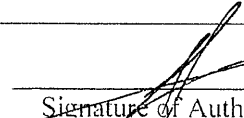

Signature of Authorized Representative

11/23/22

Date

Fernán Flores

Printed/Typed Name and Title of Authorized Representative

CONFLICT OF INTEREST QUESTIONNAIRE

FORM CIQ

For vendor doing business with local governmental entity

This questionnaire reflects changes made to the law by H.B. 23, 84th Leg., Regular Session.

This questionnaire is being filed in accordance with Chapter 176, Local Government Code, by a vendor who has a business relationship as defined by Section 176.001(1-a) with a local governmental entity and the vendor meets requirements under Section 176.006(a).

By law this questionnaire must be filed with the records administrator of the local governmental entity not later than the 7th business day after the date the vendor becomes aware of facts that require the statement to be filed. See Section 176.006(a-1), Local Government Code.

A vendor commits an offense if the vendor knowingly violates Section 176.006, Local Government Code. An offense under this section is a misdemeanor.

OFFICE USE ONLY

Date Received

1 Name of vendor who has a business relationship with local governmental entity.

2 Check this box if you are filing an update to a previously filed questionnaire. (The law requires that you file an updated completed questionnaire with the appropriate filing authority not later than the 7th business day after the date on which you became aware that the originally filed questionnaire was incomplete or inaccurate.)

3 Name of local government officer about whom the information is being disclosed.

Name of Officer

4 Describe each employment or other business relationship with the local government officer, or a family member of the officer, as described by Section 176.003(a)(2)(A). Also describe any family relationship with the local government officer. Complete subparts A and B for each employment or business relationship described. Attach additional pages to this Form CIQ as necessary.

A. Is the local government officer or a family member of the officer receiving or likely to receive taxable income, other than investment income, from the vendor?

Yes No

B. Is the vendor receiving or likely to receive taxable income, other than investment income, from or at the direction of the local government officer or a family member of the officer AND the taxable income is not received from the local governmental entity?

Yes No

5 Describe each employment or business relationship that the vendor named in Section 1 maintains with a corporation or other business entity with respect to which the local government officer serves as an officer or director, or holds an ownership interest of one percent or more.

6 Check this box if the vendor has given the local government officer or a family member of the officer one or more gifts as described in Section 176.003(a)(2)(B), excluding gifts described in Section 176.003(a-1).

7 _____
Signature of vendor doing business with the governmental entity

11-22-22
Date

CONFLICT OF INTEREST QUESTIONNAIRE
For vendor doing business with local governmental entity

A complete copy of Chapter 176 of the Local Government Code may be found at <http://www.statutes.legis.state.tx.us/Docs/LG/htm/LG.176.htm>. For easy reference, below are some of the sections cited on this form.

Local Government Code § 176.001(1-a): "Business relationship" means a connection between two or more parties based on commercial activity of one of the parties. The term does not include a connection based on:

- (A) a transaction that is subject to rate or fee regulation by a federal, state, or local governmental entity or an agency of a federal, state, or local governmental entity;
- (B) a transaction conducted at a price and subject to terms available to the public; or
- (C) a purchase or lease of goods or services from a person that is chartered by a state or federal agency and that is subject to regular examination by, and reporting to, that agency.

Local Government Code § 176.003(a)(2)(A) and (B):

(a) A local government officer shall file a conflicts disclosure statement with respect to a vendor if:

(2) the vendor:

- (A) has an employment or other business relationship with the local government officer or a family member of the officer that results in the officer or family member receiving taxable income, other than investment income, that exceeds \$2,500 during the 12-month period preceding the date that the officer becomes aware that
 - (i) a contract between the local governmental entity and vendor has been executed;
 - or
 - (ii) the local governmental entity is considering entering into a contract with the vendor;
- (B) has given to the local government officer or a family member of the officer one or more gifts that have an aggregate value of more than \$100 in the 12-month period preceding the date the officer becomes aware that:
 - (i) a contract between the local governmental entity and vendor has been executed; or
 - (ii) the local governmental entity is considering entering into a contract with the vendor.

Local Government Code § 176.006(a) and (a-1)

(a) A vendor shall file a completed conflict of interest questionnaire if the vendor has a business relationship with a local governmental entity and:

- (1) has an employment or other business relationship with a local government officer of that local governmental entity, or a family member of the officer, described by Section 176.003(a)(2)(A);
- (2) has given a local government officer of that local governmental entity, or a family member of the officer, one or more gifts with the aggregate value specified by Section 176.003(a)(2)(B), excluding any gift described by Section 176.003(a-1); or
- (3) has a family relationship with a local government officer of that local governmental entity.

(a-1) The completed conflict of interest questionnaire must be filed with the appropriate records administrator not later than the seventh business day after the later of:

- (1) the date that the vendor:
 - (A) begins discussions or negotiations to enter into a contract with the local governmental entity; or
 - (B) submits to the local governmental entity an application, response to a request for proposals or bids, correspondence, or another writing related to a potential contract with the local governmental entity; or
- (2) the date the vendor becomes aware:
 - (A) of an employment or other business relationship with a local government officer, or a family member of the officer, described by Subsection (a);
 - (B) that the vendor has given one or more gifts described by Subsection (a); or
 - (C) of a family relationship with a local government officer.

PROOF OF NO DELINQUENT TAXES OWED TO WEBB COUNTY

Name Fermin Flores owes no delinquent property taxes to Webb County.

Audio Dynamics. owes no property taxes as a business in Webb County.
(Business Name)

Fermin Flores owes no property taxes as a resident of Webb County.
(Business Owner)

Person who can attest to the above information

*** SIGNED NOTORIZED DOCUMENT AND PROOF OF NO DELINQUENT TAXES TO WEBB COUNTY.**

The State of Texas

County of Webb

Before me, a Notary Public, on this day personally appeared Fermin Flores, know to me (or proved to me on the oath of Ted C) to be the person whose name is subscribed to the forgoing instrument and acknowledged to me that he executed the same for the purpose and consideration therein expressed.

Given under my hand and seal of office this 02 day of November 2024.

Notary Public, State of Texas



(Print name of Notary Public here)

My commission expires the 30 day of August 2024.

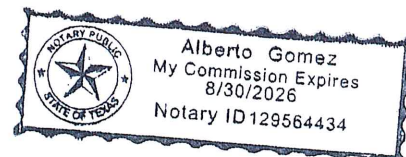

**WEBB COUNTY PURCHASING DEPT.
QUALIFIED PARTICIPATING VENDOR CODE OF ETHICS
AFFIDAVIT FORM**

STATE OF TEXAS *

KNOW ALL MEN BY THESE PRESENTS:

COUNTY OF WEBB *

BEFORE ME the undersigned Notary Public, appeared Fermin Flores, the herein-named "Affiant", who is a resident of Webb County, State of Texas and upon his/her respective oath, either individually and/or behalf of their respective company/entity, do hereby state that I have personal knowledge of the following facts, statements, matters, and/or other matters set forth herein are true and correct to the best of my knowledge.

I personally, and/or in my respective authority/capacity on behalf of my company/entity do hereby confirm that I have reviewed and agree to fully comply with all the terms, duties, ethical policy obligations and/or conditions as required to be a qualified participating vendor with Webb County, Texas as set forth in the Webb County Purchasing Code of Ethics Policy posted at the following address: <http://www.webbcountytexas.gov/PurchasingAgent/PurchasingEthicsPolicy.pdf>

I personally, and/or in my respective authority/capacity on behalf of my company/entity do hereby further acknowledge, agree and understand that as a participating vendor with Webb County, Texas on any active solicitation/proposal/qualification that I and/or my company/entity failure to comply with the Code of Ethics policy may result in my and/or my company/entity disqualification, debarment or make void my contract awarded to me, my company/entity by Webb County. I agree to communicate with the Purchasing Agent or his designees should I have questions or concerns regarding this policy to ensure full compliance by contacting the Webb County Purchasing Dept. via telephone at (956) 523-4125 or e-mail to the Webb County Purchasing Agent to joel@webbcountytexas.gov.

Executed and dated this 22 day of November, 2022

Signature of Affiant

Fermin Flores
Printed Name of Affiant/Company/Entity

SWORN to and subscribed before me, this 02 day November, 2022

Alberto Gomez
NOTARY PUBLIC, STATE OF TEXAS

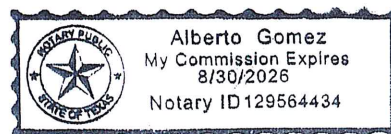

Offeror: Complete & Return this Form with Response Submission.

House Bill 89 Verification

I, Fermin flores, the undersigned representative of (company or business name) Audio Dynamics Inc. (heretofore referred to as company) being an adult over the age of eighteen (18) years of age, after being duly sworn by the undersigned notary, do hereby depose and verify under oath that the company named above, under the provisions of Subtitle F, Title 10, Government Code Chapter 2270:

- 1. Does not boycott Israel currently; and
- 2. Will not boycott Israel during the term of the contract.

Pursuant to Section 2270.001, Texas Government Code:

- 1. "Boycott Israel" means refusing to deal with, terminating business activities with, or otherwise taking any action that is intended to penalize, inflict economic harm on, or limit commercial relations specifically with Israel, or with a person or entity doing business in Israel or in an Israeli-controlled territory, but does not include an action made ordinary business purposes; and
- 2. "Company" means a for-profit sole proprietorship, organization, association, corporation, partnership, joint venture, limited partnership, limited liability partnership, or an limited liability company, including a wholly owned subsidiary, majority-owned subsidiary, parent company or affiliate of those entities or business association that exist to make a profit.

Signature of Company Representative

11-22-22
Date

On this 21 day of November, 2022, personally appeared

Fermin flores, the above named person, who after by me being duly sworn, did swear and confirm that the above is true and correct.

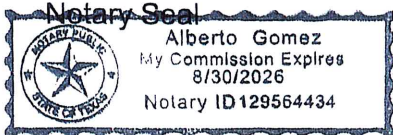

Alberto Gomez
Notary Signature
11/22/22
Date

**Offeror: Complete & Return this Form with Response Submission.
Senate Bill 252 Certification**

SB 252 CHAPTER 2252 CERTIFICATION I, fermin flores., the undersigned representative of Audio Dynamics Inc. (Company or business name) being an adult over the age of eighteen (18) years of age, pursuant to Texas Government Code, Chapter 2252, Section 2252.152 and Section 2252.153, certify that the company named above is not listed on the website of the Comptroller of the State of Texas concerning the listing of companies that are identified under Section 806.051, Section 807.051 or Section 2253.153. I further certify that should the above-named company enter into a contract that is on said listing of companies on the website of the Comptroller of the State of Texas which do business with Iran, Sudan or any Foreign Terrorist Organization, I will immediately notify Mr. Jose Angel Lopez III, Webb County Purchasing Agent at (956) 523-4125 or via email at joel@webbcountytx.gov

Audio Dynamics Inc. Name of Company Representative (Print)



Signature of Company Representative

11-22-22

Date

References Form

Please list at minimum five (5) local governmental entities where similar scope of services were provided.

THIS FORM MUST BE RETURNED WITH YOUR OFFER.

REFERENCE ONE

Government/Company Name: Cold chain solutions.

Address: 810 Union Pacific Blvd.

Contact Person and Title: Erwin Hechter

Phone: 956-235-9102. Fax: _____

Email Address: erwin@cold-chain.us Contract Period: _____

Description of Professional Services Provided: Audio Dynamics Inc, has installed Avigilon cameras, Avigilon servers and access control throughout our warehouse

REFERENCE TWO

Government/Company Name: Doctors Hospital of haredo

Address: 10700 McPherson Rd.

Contact Person and Title: Sesse Medina

Phone: 956-744-3022. Fax: _____

Email Address: Sesse.molina@ahsinc.com Contract Period: _____

Description of Professional Services Provided: Audio Dynamics Inc, has provided Doctors Hospital with all types of services for our facilities. they have installed and monitored our Emergency Clinics with alarm panic systems for these facilities incase of emergencies.

REFERENCE THREE

Government/Company Name: Gontor Logistics.

Address: 13713 n. Unitec Dr.

Contact Person and Title: Victor Garza

Phone: 956-415-3508 Fax: _____

Email Address: vgarza@gontor.com Contract Period: _____

Description of Professional Services Provided: Audio Dynamics, Inc. has installed avigilon cameras, avigilon servers and paxton access control throughout our tracking facilities and warehouses.

REFERENCE FOUR

Government/Company Name: About Time.

Address: 7220 A. Bob Bullock loop Suite 4A

Contact Person and Title: Priya Vaswani

Phone: 956. 723-1198. Fax: 956-723-7663

Email Address: pv@about-time.com Contract Period: _____

Description of Professional Services Provided: Audio Dynamics Inc, was awarded the Hilton project to wire all data/voice/TV drop throughout the new hotel being built.

REFERENCE Five

Government/Company Name: Webb Country

Address: _____

Contact Person and Title: _____

Phone: _____ Fax: _____

Email Address: _____ Contract Period: _____

Description of Professional Services Provided: Audio Dynamics inc. Installed
Cameras at Webb Country Svc. They also
did audio and video on the court houses.

- **Additional pages are permitted if more space is required**

Space intentionally left Blank

Cold Chain Solutions
810 Union Pacific Blvd
Laredo, TX 78045
[\(956\) 796-1795](tel:9567961795)

Contact:
Erwin Hechtter
9562359102
erwin@cold-chain.us

Audio Dynamics, Inc. Has installed Avigilon Cameras, Avigilon Servers and Access control throughout our warehouse. The project had them design a layout for our trucking entrances, warehouse distribution and cold storages. This entailed having adequate coverage throughout the facilities to protect our customers products and safety of our employees. They have completed the work on time and to our satisfaction. Staff was on time and very professional.

They also continue to provide warranty services, maintenance of all devices and repairs needed to maintain our system fully functional 24/7.

Audio Dynamics has provided installation for our data/voice systems. They maintain our networks and wifi systems.

Doctors Hospital of Laredo
10700 McPherson Rd,
Laredo, TX 78045
(956) 727-8922

Contact:
Jesse Medina
9567443022
jesse.medina@uhsinc.com

Audio Dynamics, Inc. Has Provided Doctors Hospital with All types of services for our Facilities. Audio Dynamics Has installed and monitored our Emergency Clinics with Alarm Panic systems for these facilities incase of emergencies. These systems contact the Police dept 24/7 in case of any type of emergencies.

Audio Dynamics Has also installed Avigilon Servers and Avigilon Cameras throughout our main hospital and Our clinics through Laredo. They have installed and programmed these devices on time and to our satisfaction.

They were recently awarded a new Avigilon Project to replace our Milestone system at the FED Saunders to be upgraded to Avigilon. This will replace all servers and cameras to Avigilon. Plus add new cameras needed in some areas.

Audio Dynamics also provides maintenance of all devices and repairs needed to maintain our system fully functional 24/7.

Audio Dynamics was awarded a new Project for the Providences location to install a new Alarm Security System throughout this facility. The project is on going and being worked on at a timely manner.

Audio Dynamics also provides Doctors with Fiber and Data/Voice Drops throughout all our facilities. We sometimes need 1 Drop or 100 Drops they proved the same level of professional service. They also provided professional and safety to all our areas because of our patients and staff.

Audio Dynamics has provided design and layouts for all these systems we install.

Audio Dynamics has also provided us with Audio/Video installation for some areas like conference rooms and Doctors meeting rooms. They have installed Audio PA systems, Music systems and conference room systems.

Gontor Logistics
13713 N Unitec Dr
Laredo, TX 78045

Victor Garza
9564153508
vgarza@gontor.com

Audio Dynamics Has installed Avigilon Cameras, Avigilon server and Paxton Access Control throughout our Trucking facilities and warehouses in Laredo. They installed and programmed all devices on time and with satisfaction.

In our Outdoor trucking area, they have installed under ground Fiber and under ground copper with conduit for our outdoor camera, and Wi-Fi systems. Cameras were installed in various location from poles to outdoor docks. To monitor our clients' products and safety of our employees.

Audio Dynamics has installed Avigilon Servers and Cameras in our warehouses. They wired and installed all devices to our satisfaction. They finished all work on time and with professionalism.

Audio Dynamics Installed Paxton access control throughout our warehouse and guard shacks with access control systems to protect our facilities from non-personnel entering our facilities and offices.

Audio Dynamics continues to provide service and maintenance to our systems, they respond quickly to our calls within a 24 hour time period.

About-Time
Hilton Hotel
La Quinta
RAMS Hotel Management
Laredo Heat Soccer Club
pv@about-time.com
7220-A Bob Bullock Loop Suite 4-A
Laredo Texas 78041
tel: 956-723-1198
fax: 956-723-7663
Cel: 9562061198

Audio Dynamics was awarded the Hilton project to Wire all data/voice/TV drop throughout the new hotel being built. The work was finished on time and clean. They installed all data racks and IT rooms to our satisfaction. All drops were tested and certified by their team. They also provided installation for our computers and fax devices in our main lobbies.

Audio Dynamics Designed, installed and programmed our audio/video conference rooms with Crestron, TOA electronics and Wyrestorm audio equipment. These rooms are used for various events with TVS and Projects for presentations.

Audio Dynamics install and programmed our IP cameras system from Hikvision throughout the hotel for the safety of our clients and employees.

Audio Dynamics has installed data/voice/TV for our La Quinta Location. They also did our camera system upgrade.

Audio Dynamics was recently awarded the work to upgrade La Quinta's Wi-Fi network. They installed a cloud-based Access Point system. Which they programmed and provided low down time to our hotel.

Audio Dynamics also provides 24/7 Monitoring of Fire and Alarm systems for all our Offices, apartment buildings and Hotels. They respond very quickly to service and fix the issues quickly.

Audio Dynamics Also provides me with service and installation of Alarm/ Audio/Video/ Cameras for my personal homes here in Laredo and San Antonio. The camera system we have used in our homes is Avigilon servers and cameras.

Audio Dynamics has provided us with many years of services they have always finished their jobs in a timely manner and to our satisfaction.