

Webb County, TX

Request for Proposal (RFP)

RFP 2023-007 Audio Video Broadcasting Equipment Addendum 2 (ARPA Project No. 16)

Mr. Juan Guerrero
Webb County Purchasing Department
1110 Washington Street, Suite 101
Laredo, Texas 78040

Please note that the following proposal offers all aspects of the EQUIPMENT portion of the RFP. Though it does offer the ability to broadcast to your television station and the gallery, and offers capability to stream to YouTube, it does not cover all aspects noted in the BROADCASTING portion of the RFP such as captioning. BIS Digital is prepared to offer the appropriate signal flow to broadcast vendor as needed.



1350 NE 56th Street, Suite 300
Ft. Lauderdale, FL 33334



Sales: (800) 834-7674
Support: (800) 715-1234



Email: info@bisdigital.com
Web: www.bisdigital.com



April 20, 2023

Mr. Juan Guerrero

Webb County Purchasing Department
1110 Washington Street, Suite 101
Laredo, Texas, 78040
juguerrero@webbcountytx.gov

Mr. Guerrero,

Thank you for considering BIS Digital for your audio and video needs. We are pleased to submit our proposal in response to your request.

Attached to this proposal, you will find detailed information about our products and services, as well as pricing and terms. We believe that our proposal represents the best value for Webb County, TX, and we look forward to the opportunity to work with you.

If you have any questions or would like to discuss this proposal further, please do not hesitate to contact us.

Sincerely,

Brandy Johnson
Account Manager
brandy.johnson@bisdigital.com

A handwritten signature in black ink that reads 'Brandy Johnson' in a cursive script.

Proposal Information

Title of Proposal:

RFP 2023-007 Audio Video Broadcasting Equipment Addendum 2 (ARPA Project No. 16)

Proposal Total:

\$180,894.69

BIS Digital Proposal Reference ID:

P-2300207

Intended Recipient Name (Attention To):

Mr. Juan Guerrero

Contract Number:

TIPS Contract 220704 - Audio Visual Equipment, Supplies, and Services

Delivery Address:

Webb County Purchasing Department,
1110 Washington Street, Suite 101
Laredo, Texas, 78040

Submitting Organization Information

Name:

Business Information Systems, Inc. DBA: BIS Digital

Address:

1350 NE 56th Street, Suite 300
Fort Lauderdale, FL 33334

Phone:

(800) 834-7674
(954) 493-7377

Account Manager Email:

brandy.johnson@bisdigital.com

Account Manager Phone:

(800) 834-7674 x. 4553

Website:

www.bisdigital.com

Fax:

(877) 858-5611

Statement:

BIS Digital certifies that we meet or exceed all the necessary requirements outlined in this Request for Proposal (RFP). Our responses to the RFP are truthful and accurate, and our pricing remains valid for the duration of this bidding process. We are confident in our ability to fulfill the requirements of this opportunity and look forward to the opportunity to work with your organization. The authorized signer affirms the above statements upon signing below.

Account Manager:

Brandy Johnson

Date:

April 20, 2023

A handwritten signature in black ink that reads 'Brandy Johnson'.

b. Executive Summary

BIS Digital has been in the audio and video industry since 1982 and possesses a wealth of experience in providing integrated solutions for entities of all sizes. Headquartered in Ft. Lauderdale, Florida, the company has over 90 employees with direct sales and service representatives throughout the US.

Our primary business is the sale, service, and support of multi-channel digital audio/video recording software for the judicial and courtroom systems; city/county governments; public safety and interview rooms; and private enterprises. Other areas of expertise include software-based enterprise room control, AV electronic hardware and software integration, video presentation technology and tv broadcast systems, and digital sound/audio reinforcement.

In addition to our comprehensive AV solutions, we provide a range of video conferencing options for remote video arraignment and other court conferencing needs, in either hosted or non-hosted formats. We also offer remote language translation connectivity and digital dictation, as well as meeting agenda automation, live streaming, web hosting, and on-demand systems. From concept to completion, we have provided these technologies to over 6,000 customers.

The strategic direction for BIS digital has been to develop solutions that operate in an open architecture environment, are user-friendly, and can be accessed on PCs, tablets, and smartphones. We work with award-winning manufacturers to design fully integrated AV capabilities for optimal workflow and efficiency. All our solutions are developed to work seamlessly with our core DCR audio and video recording software and any current case management software being utilized in the courts and other spaces today.

As such, our team has a deep understanding of the unique requirements in these settings and the importance of reliable and effective AV systems. Our priority is to work closely with our clients to ascertain their specific needs and design a system that meets them. With that said, to us, technology integration and support is more than a project. It's a partnership. It's why we also offer ongoing maintenance and support for our AV systems, as well as providing training and technical assistance to users. We strive to build long-lasting relationships with our clients and exceed their expectations at every opportunity.

c. Table of Contents

Page numbers match pdf document page numbers as well as labeled page numbers

Item	Page
a. Transmittal Letter	2
b. Executive Summary	4
c. Table of Contents	5
d. Experience with Audio/Video & Broadcasting Equipment	6
e. Personnel Qualifications	8
f. Price Proposal	9
1. Scope of Work - SIGNATURE	12
2. Workflow - SIGNATURE	21
3. Terms and Conditions	22
4. Acceptance Page - SIGNATURE	23
g. References and Projects	24
h. Additional Items	27
1. Optional Support Plan Overview and Pricing	27
2. Product Introductions	28
a. Cynap (item included in quote)	29
b. Televic Microphones (item included in quote)	37
3. Installation Overview	38

d. Experience with Audio/Video Equipment and Broadcasting

Name:

Business Information Systems, Inc. DBA: BIS
Digital

Address:

1350 NE 56th Street, Suite 300
Fort Lauderdale, FL 33334

Website:

www.bisdigital.com

Years in Business

41

Number of Employees

90

Geographic Reach

US + 6 Countries

Office Locations

Texas, Florida, Georgia, Alabama,
Tennessee, Kentucky, Ohio, Michigan,
Arkansas, New York, New Jersey, North
Carolina, South Carolina, Washington DC

Financial Information

BIS Digital is a privately held corporation.
Submission of confidential financial
information can be delivered upon request.

Certifications

BIS Digital is a Certified Reseller and
Authorized Support Agency for the
following manufacturers (including but not
limited to):

- ASC
- Ashly
- Atlona
- Audio-Technica
- Axis
- Biamp
- Dante
- Extron
- Philips
- QSC
- Shure
- Sony
- Televic
- Williams Sound
- WolfVision

Owner / CEO

Steve Coldren

Vice President

Kirk Ambrose

CFO

Isabel Valle

**Director
Operations**

Gary Jones

Territory Director

Marty Ybarra

Account Manager

Brandy Johnson

System Engineer

Matthew Chetcuti

Project Manager

Rosie Socolovitch

Phone:

(800)834-7674
(954) 493-7377

Account Manager Phone:

(800) 834-7674 x. 4553

Account Manger Email:

brandy.johnson@bisdigital.com

Fax:

(877) 858-5611

Statement

BIS Digital certifies that we meet or exceed all the necessary requirements outlined in this Request for Proposal (RFP). Our responses to the RFP are truthful and accurate, and our pricing remains valid for the duration of this bidding process. We are confident in our ability to fulfill the requirements of this opportunity and look forward to the opportunity to work with your organization. The authorized signer affirms the above statements upon signing below.

Account Manager:

Brandy Johnson



Audio/Video Equipment and Broadcasting Experience (continued)

BIS Digital has provided tens of thousands of clients with audio visual integration across the country. We currently have offices in 15 states but will often cross state borders to offer our services throughout the Eastern and Southern US. We primarily support Government and Courts, Law Enforcement, and Children's Advocacy Centers, providing top of the line technology to ensure flawless communication both within and outside of the room.

We have completed integration in many courts at all levels including Federal and State Courts such as the Texas Criminal Court of Appeals, as well as District, County, and Municipal Courts such as 63rd and 83rd Districts in Val Verde County, or Arlington Municipal Court in the Dallas Metroplex.

We also support many law enforcement agencies such as the Border Patrol in Laredo, TX, and have provided our Children's advocacy clients with specialized interview integration in several locations such as Harold's House in Nacogdoches, TX or The Martin House in Longview, TX.

We providing a full range of audio visual and integration services including but not limited to microphones, sound systems, video displays, video signage, video switching and routing, broadcast, hybrid video conferencing, recording, virtual court, and audio/video security features. We regularly receive referrals from Offices of Court Administration throughout the country, including Texas, for our services.

Our clients have had some wonderful things to say about us:

"Alex's training and updating our BIS software was probably one of the best sessions I have had in my very long career. His knowledge was impeccable, and patience was above and beyond."

- Rebecca V, North Texas Client

"I want to thank you for your quick response and service. You gave me a lot of patience and guidance in making the decision with Televic and Cynap. We've had a lot of comments in respect to the improvement of the audio and video system in our chambers and the Cynap/Televic system themselves and the ease with which to use them. Day and night from what we were doing before."

- Tim G, Florida Client

e. Personnel Qualifications

Brandy Johnson

Brandy is your South Texas Account Manager at BIS Digital and has been with the company since 2020. Brandy has extensive experience in the field of audio visual with over 18 years of experience in system operation, design, and account management. Brandy began her career as the audio engineer for Citigroup's CIB headquarters in NYC, but quickly developed her expertise in all fields of audio visual. Brandy supported live events in an Account Manager and Sales Director role for 10+ years, and recently served The Ritz-Carlton in Dallas as the Director of all things technology prior to moving into the integration arena in 2019. Some of Brandy's recent integration projects include Austin County Justice Center, Fellowship Church in Dallas, Val Verde County and District Courts, as well as Panola County County and District Courts. Brandy's #1 purpose is to ensure your satisfaction with the product and support you receive from BIS Digital.

Kevin Wingard

Kevin is one of our Texas-based Field Technicians who will lead your installation team on-site and will ensure everything is installed to standard, training is complete, and that you are satisfied. Kevin has represented BIS Digital since 2014, but began working in judicial audio visual integration years before, giving him 14 years of experience successfully completing projects like those contained in this proposal. Kevin has completed installations for hundreds of clients around Texas, including Austin County and District Courts, Panola County and District Courts, Val Verde County Court at Law and Commissioners Court, and Harris County Sheriff's Office. Kevin has expertise in all areas of audio visual integration including sound systems and microphones, video broadcast and conferencing, and of course our full line of DCR recording software.

Alex Aponte

Alex is a Technical Services Representative at BIS Digital, where he has been employed since 1998. He is highly skilled in the DCR and Winscribe software packages and has a deep understanding of computer and video hardware. In addition to his work in the US, Alex has also led installations and training of DCR systems for all the courts in Puerto Rico. He has worked on several key integrations, including a project in Ward County, Texas, where he helped install BIS Digital's full line of digital recording and A/V products. The system offers unique controls to the judge via a web browser and can be customized to meet the court's needs, including evidence presentation. In the City of Harlingen, Texas, Alex worked on a DCR two-channel system with video conferencing and implemented the DCR Remote and Monitor option, allowing the system administrator to control the DCR system from anywhere on the network.

Jonathan Grimes

Jonathan is a Technical Services Representative at BIS Digital, where he has been employed since 2013. He is an experienced A/V integrator and one of the most knowledgeable field technicians at BIS Digital. Jonathan is CTS certified and provides support for a variety of systems, including DCR, DCR2, and DCR-IR. He has worked on several key integrations, including projects in Saline County, Arkansas, and Andrews County, Texas. In both counties, he helped install sound and presentation systems provided by BIS Digital and implemented custom hardware control integrations that allow for the control of the entire system from any device via a web browser.

f. Price Proposal

Account Name:
Webb County, TX

Quote Name:
I - APR 2023 - Commissioners Court Full System - Commissioners Courtroom - County Courthouse
- Webb County, TX

Quote Number: Q-8023139 **Quote Amount:** \$180,894.69 **Date:** 4/24/23 **Quote Expiration Date:** 10/24/23

Account Rep: Brandy Johnson **Account Rep Email:** brandy.johnson@bisdigital.com **Account Rep Phone:** (800) 834-7674 x4553

Item	Product Code	Qty	List Price	TIPS Price	Total Price
IP DVR Core License (Series 2)	BIS-IP-DVR-CS2	6.00	150.00	\$135.00	\$810.00
Conference System Wireless Conference Unit (GO-G4) Series 4	BIS-CONF-W-GO-G4-S4	11.00	1350.00	\$1,215.00	\$13,365.00
70" Commercial Display 4K	BIS-D-4K-70-C	2.00	2550.00	\$2,295.00	\$4,590.00
5.25" Indoor/Outdoor Wall Mount Speaker Pair (Black)	BIS-SP-WMB	1.00	645.00	\$580.50	\$580.50
Power Amplifier 4ch. 250W 70v Series 4	BIS-AMP-4C250-70S2	1.00	3150.00	\$2,835.00	\$2,835.00
6.5" Wall Mount Speakers - Black (Pair)	BIS-SP-WMB-6.5	4.00	930.00	\$837.00	\$3,348.00
Network Switch w/PoE 24-port (Series 8)	BIS-NS-POE-24-S8	1.00	1670.00	\$1,503.00	\$1,503.00
HDMI and SDI Cross Converter with Scaling and Frame Rate Conversion	BIS-HDMI-SDI-Converter	4.00	550.00	\$495.00	\$1,980.00
UPS 8 Outlet/1500VA 2RU	BIS-R-UPS-1500	2.00	1300.00	\$1,170.00	\$2,340.00
IP Camera Control Board	BIS-IP-CCB	1.00	1800.00	\$1,620.00	\$1,620.00
Blu-Ray Player Commercial Grade Rackmount Series 3	BIS-Blu-Ray-CS3	1.00	645.00	\$580.50	\$580.50
Fold Flat LED Touch Screen 22" (Series 4)	BIS-FD-LEDTS-22-S4	5.00	580.00	\$522.00	\$2,610.00
Duo Rackmount Broadcast Video Monitors	BIS-BSC-RCK-DMON	4.00	1400.00	\$1,260.00	\$5,040.00
HD IP PTZ Camera 4K (Series 3)	BIS-HD-IP-PTZ-4K-S3	6.00	3975.00	\$3,577.50	\$21,465.00

Item	Product Code	Qty	List Price	TIPS Price	Total Price
32" Commerical Display 4K	BIS-D-4K-32-C	1.00	1100.00	\$990.00	\$990.00
Speaker Volume Control Panel 70V (Series 3)	BIS-SP-VC-70V-S3	1.00	100.00	\$90.00	\$90.00
Professional Digital PA Mixer DANTE Capable w/8ch USB out	BIS-MX-DAN-USB8	1.00	4730.00	\$4,257.00	\$4,257.00
Conference System Charging Tray for 10 Battery Packs (G4) 19" Rack mountable Series 4	BIS-CONF-10BPCT-S4	2.00	1695.00	\$1,525.50	\$3,051.00
Conference System 16" Gooseneck Microphone for G4 system only Series 4	BIS-CONF-16GN-G4-S3	11.00	330.00	\$297.00	\$3,267.00
Conference System Wireless Conference Access Point (G4) w/ Dante Interface Series 4	BIS-CONF-WCAP-WD-S4	1.00	4995.00	\$4,495.50	\$4,495.50
Conference System Battery Pack for Wireless Conference Unit (G4) Series 4	BIS-CONF-BP-WCU-S4	11.00	250.00	\$225.00	\$2,475.00
12-bay Charging Station DigiWave Transceiver and Receiver (Series 4)	BIS-ALS-12BCS-FDTR-S4	1.00	650.00	\$585.00	\$585.00
DigiWave Transceiver (Series 4)	BIS-ALS-DWT-S4	3.00	625.00	\$562.50	\$1,687.50
Black Silicone Skin for DigiWave Transceiver and Receiver (Series 4)	BIS-ALS-BKSS-FDTR-S4	3.00	29.00	\$26.10	\$78.30
Headset Microphone for DigiWave (Mini Mic Plug, Mini Headset Plug)	BIS-ALS-HM	3.00	180.00	\$162.00	\$486.00
Conference System Audio Engine w/ Dante Card Series 3	BIS-CONF-AEWD-S3	1.00	6300.00	\$5,670.00	\$5,670.00
7" Tabletop TouchLink Room Control Panel (White)	BIS-EXTRN-TL-725T-W	2.00	2650.00	\$2,385.00	\$4,770.00
Room Control Processor 360 (Series E)	BIS-E-RCP-360	1.00	3250.00	\$2,925.00	\$2,925.00
4K/60 HDMI DTP Receiver (330ft)	BIS-EXTRN-DTP-HDMI-4K-330-RX	9.00	700.00	\$630.00	\$5,670.00
SATA 2.5" SSD 2TB	BIS-SSD-SATA-2.5-2TB	2.00	375.00	\$337.50	\$675.00
Rackmount AV 4K Recorder (Series 1)	BIS-RM-AV-4K-REC-S1	1.00	2400.00	\$2,160.00	\$2,160.00
Broadcast Switcher & Control Board 4K Pro Series 3 (HD/SD-SDI)	BIS-SW-BSCB-4K-HDSDI-S3	1.00	3600.00	\$3,240.00	\$3,240.00
4K/60 HDMI DTP Transmitter (330ft)	BIS-EXTRN-DTP-HDMI-4K-330-TX	2.00	700.00	\$630.00	\$1,260.00
4K/60 HDMI to DTP Distribution Amplifier 1x8 (330ft)	BIS-EXTRN-DTP-HD-DA-4K-330-8	1.00	4750.00	\$4,275.00	\$4,275.00
USB 3.0 to HDMI Video Output Adapter	BIS-USB3-HDMI-VOA	2.00	100.00	\$90.00	\$180.00
Annotation Presentation System w/Wireless Link (Pro)	BIS-CYNAP-PRO	1.00	8000.00	\$7,200.00	\$7,200.00

Item	Product Code	Qty	List Price	TIPS Price	Total Price
4K/60 8x4 HDMI-DTP Matrix Switcher	BIS-EXTRN-SMX-84-HDMI-DTP	1.00	11990.00	\$10,791.00	\$10,791.00
Digital Document Camera (Gen.6)	BIS-DDC-GEN6	1.00	4600.00	\$4,140.00	\$4,140.00
24" Monitor for PC Height Adjustable w/ Speakers HDMI DP VGA	BIS-24-MON-PC-T	1.00	395.00	\$355.50	\$355.50
Speaker Wire 16AWG (Plenum) - 500ft Roll	BIS-W-SPKR-16AWG-500ft	1.00	215.00	\$193.50	\$193.50
6' Shielded CAT6 Patch Cable Plenum	BIS-CAT6-SPC-6-P	60.00	58.00	\$52.20	\$3,132.00
HDMI Cable Series 2 (6ft.)	BIS-HDMI-6FT-S2	20.00	20.00	\$18.00	\$360.00
CAT6 Cable Shielded Black 1000'	BIS-W-CAT6-SHB-1000	2.00	1325.00	\$1,192.50	\$2,385.00
HD-SDI Cable (1000ft)	BIS-HSDI-CX	1.00	1200.00	\$1,080.00	\$1,080.00
DANTE USB I/O Adapter (2ch)	BIS-USB-DANTE-2CHIO	1.00	250.00	\$225.00	\$225.00
Raceway Wire Cover (50ft)	BIS-CBL-RWC-50	4.00	120.00	\$108.00	\$432.00
Full Motion Desk Mount (13" - 27")	BIS-MNT-DM-1327	1.00	200.00	\$180.00	\$180.00
40"-90" Commercial Grade Full Motion Wall Mount 150lbs Max	BIS-CGD-WMT-FM-40-90	2.00	799.00	\$719.10	\$1,438.20
Installation Supplies	BIS-INST-SUP	1.00	2304.15	\$2,073.74	\$2,073.74
Custom Programming (1 hour)	PRGM	1.00	385.00	\$346.50	\$346.50
On-site Setup, Installation and Training	SIT	1.00	23760.00	\$21,384.00	\$21,384.00
Shipping/Handling	S/H	1.00	11359.95	\$10,223.96	\$10,223.96
TIPS Contract 220704 - Audio Visual Equipment, Supplies, and Services	BIS-X-TIPS				

Total (Before Tax): \$180,894.69

f.1 General Scope of Work Description for Installations

BIS Digital is committed to delivering high-quality AV systems that meet the needs of our clients; our Scope of Work process is an integral part of this commitment. Please note that this document is intended as a preliminary assessment only and may be subject to a final technical assessment of your requirements. Its use is limited to the purpose of allowing you to verify, via signature, whether the listed equipment, software, and installation needs were accurately recorded. The final implementation of equipment and functionality may vary due to factors including but not limited to: budget, infrastructure, and manufacturer constraints. This document does not provide any implied or express warranties, and BIS Digital accepts no liability for any reliance on the information contained within it beyond its intended purpose as an initial work assessment. Unless otherwise specified, the following section lists BIS Digital and client responsibilities for a standard installation.

BIS Digital will be responsible for the following:

- Provision of all necessary labor, supervision, tools, equipment, materials, services, testing, and other expenses for the successful installation and delivery of a complete and operable A/V solution.
- Performance of all work as described in the scope of work, including installation and testing of specified equipment and final circuit terminations in the head-end equipment racks.
- Project management, personnel, supervision, staff, labor, installation planning, scheduling, documentation, installation quality, and testing devices as required to complete the work.
- Furnishing of specified equipment, with the caveat that BIS Digital reserves the right to bill for equipment as stored materials when delivery or installation is not possible.
- Recommendation for the installation of dedicated electrical power at the head-end, end-user equipment, or at the location of final control(s).
- Production of deliverables and any substitutions on a schedule established under a purchase agreement.

The client will be responsible for the following:

- Preparation of the installation site, including but not limited to carpentry, network connection installation, and electrical work.
- Provision of scaffolds, ladders, or high-reach equipment for installation work in ceilings over 14 feet.
- Responsibility for any external noise or factors creating noise within the systems not exposed by installed electronic equipment.
- Ensuring that installation structures will support the weight of equipment, including but not limited to wall-mounted displays, hanging loudspeakers, and equipment racks.
- If required, customer-provided contractors will be responsible for the provision, hanging, and installation of all rigid electrical junction boxes, AC power, relay switches, conduits, and any structural reinforcement means as required for the proposed systems.

By signing below, I certify that I am an authorized signer for Webb County, TX and have reviewed and approve the Scope of Work provided by BIS Digital. I understand that this Scope of Work defines the equipment requirements for the project, and certify this document accurately captures the needs of my organization. I also acknowledge that any changes to the Scope of Work must be approved in writing by all parties involved.

Client Name _____ Signature _____ Date _____

Installation (I) - BIS-3000350

Webb County, TX

Brandy Johnson
brandy.johnson@bisdigital.com

Commissioners Courtroom

Will this Scope of Work apply to multiple rooms?

No -- This scope does NOT consider multiple rooms.

Description / Notes:

BIS Digital will provide and install a fully integrated audio/visual system. Please see Attachment A for additional Details.

Audio Feeds

A1 Location: Other (see notes)	A1 Status: Provide 11 New	A1 Placement: Desk-sitting	A1 Type: 18" Gooseneck (Wireless w/ Mute) Includes Speaker and Headphone connection on each microphone	A1 Function: Stream Online / VTC
A2 Location: Other (see notes)	A2 Status: Use 2 Client-Provided	A2 Placement: Other (see notes)	A2 Type: Hand-held (Wireless) Client's Existing Shure Wireless Handheld Microphones	A2 Function: Stream Online / VTC

Speakers

S1 Location: Wall A	S1 Status: Provide 2 New	S1 Type: Wall-mounted Speaker	S1 Zone: 1
S2 Location: Wall B	S2 Status: Provide 4 New	S2 Type: Wall-mounted Speaker	S2 Zone: TBD
S3 Location: Wall D	S3 Status: Provide 4 New	S3 Type: Wall-mounted Speaker	S3 Zone: TBD

Displays and Control Points

D1 Location: Bench	D1 Status: Provide 5 New	D1 Placement: Desk-sitting	D1 Content View: An Input Selected (Room Control) View	D1 Content: <ul style="list-style-type: none"> • Multi-Media 	D1 Control: <ul style="list-style-type: none"> • Source Select
D1 Size (inches): 22"	D1 Type: Monitor				
D2 Location: Wall B	D2 Status: Provide 1 New	D2 Placement: Wall-mounted (tilt)	D2 Content View: An Input Selected (Room Control) View	D2 Content: <ul style="list-style-type: none"> • Multi-Media • VTC Participants 	D2 Control: <ul style="list-style-type: none"> • Source Select
D2 Size (inches): 70"	D2 Type: Monitor				
D3 Location: Control Room	D3 Status: Provide 1 New	D3 Placement: Desk-sitting	D3 Content View: A Split Screen With Switching (via Room Control) View	D3 Content: <ul style="list-style-type: none"> • Preview • Publish • Room Cams • Multiview output from switcher to include (6) cameras, Preview, and Program 	
D3 Size (inches): 24"	D3 Type: Monitor				
D4 Location: Control Room	D4 Status: Provide 1 New	D4 Placement: Desk-sitting		D4 Content: <ul style="list-style-type: none"> • On swivel arm - used to control switcher settings and lower thirds/graphics management 	D4 Control: <ul style="list-style-type: none"> • Video Control Surface
D4 Size (inches): 24"					
D5 Location: Control Room	D5 Status: Provide 8 New	D5 Placement: Rack-mounted		D5 Content: <ul style="list-style-type: none"> • Room Cams 	

D5 Size (inches):
8"

D5 Type:
Monitor

D5 Content View:
A Single Source
(Static) View

- Camera 1, Camera 2, Camera 3, Camera 4, Camera 5, Camera 6, Preview, Program

D6 Location:
Rack

D6 Status:
Provide 1 New

D6 Placement:
Shelf-sitting

D6 Type:
Monitor

- D6 Content:**
- On top of rack, to view broadcast channel using television connection

Equipment

	Location	Status	Make / Model	Ports Available
Amplifier	Rack Room	Use 1 Client-Provided		
Desktop/Laptop	Other (see notes)	Use 3 Client-Provided		
DSP/Mixer	Rack	Provide 1 New		
Network Switch	Rack	Provide 1 New		
Power Conditioner	Rack	Provide 1 New		
Presentation System	Other (see notes)	Provide 1 New		
Video Distribution Amplifier	Rack	Provide 1 New		
Video Input Switcher	Rack	Provide 1 New		

Rack

	Location	Status	Type	Access	Conduit	Units Available
Rack 1	Control Room	Use 1 Client-Provided	Open-frame	Direct (in-room)	Existing	

System Live Streaming (NOTE: Only the sources selected in the equipment tables will appear in a live stream):

- Broadcast to City Cable Channel

System Video Teleconferencing (NOTE: Only the sources selected in the equipment tables will be used in VTC):

- WebEx

Infrastructure

Room Construction:

	Measurement (feet)	Material	Adjacent Area	Prominent Feature
Ceiling	20'	Drywall		
Wall A	100'	Drywall		
Wall B	80'	Drywall		
Wall C	100'	Drywall		
Wall D	80'	Drywall		
Floor				

On-site lockable storage?

Yes -- BIS Digital will use on-site lockable storage.

Loading dock?

N/A -- Loading dock not needed for this scope.

Network Approval Process?

Unknown

Access above ceiling?

No -- There is no access to any ceiling.

Any ceiling height on-site greater than 12 feet?

N/A -- BIS Digital does not need to access the ceiling.

Known asbestos?

Unknown -- Client is not aware of any asbestos at time of scope, but knows that remediation will be necessary if discovered.

Commissioner's Bench

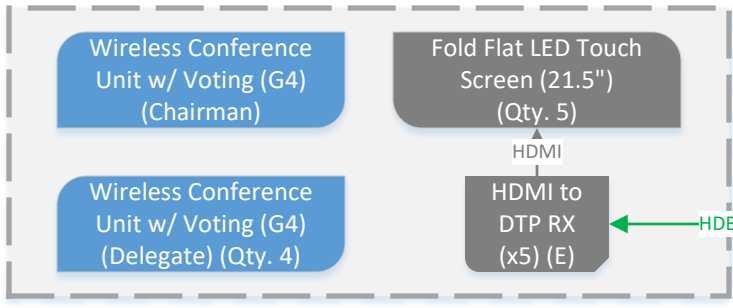

Podium



AV Table

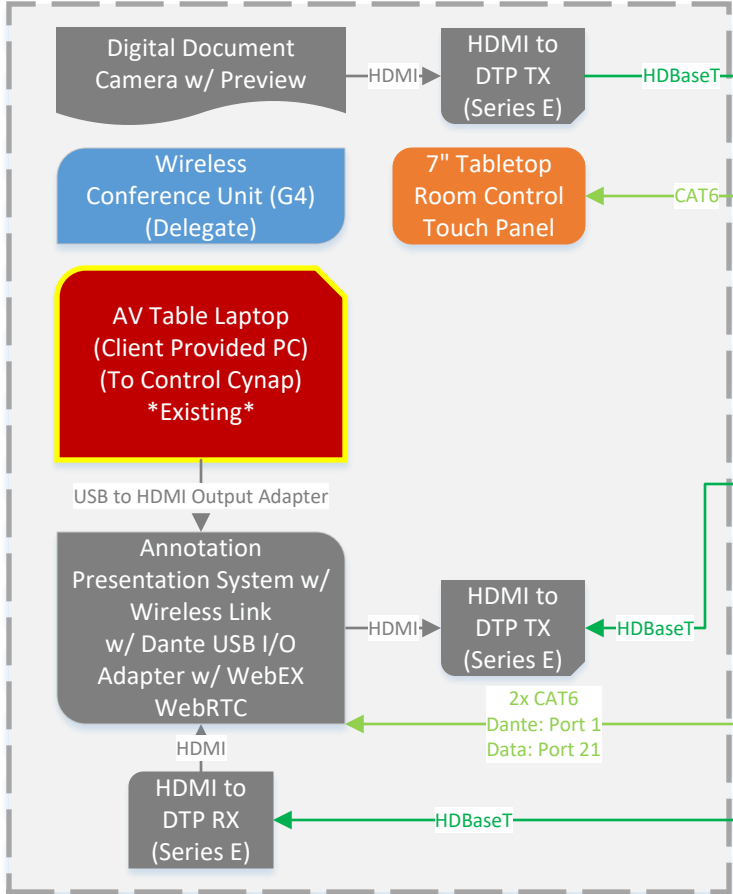

Department Heads Table

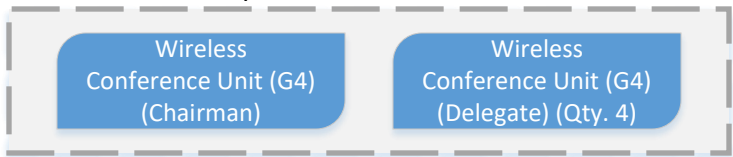

Wall

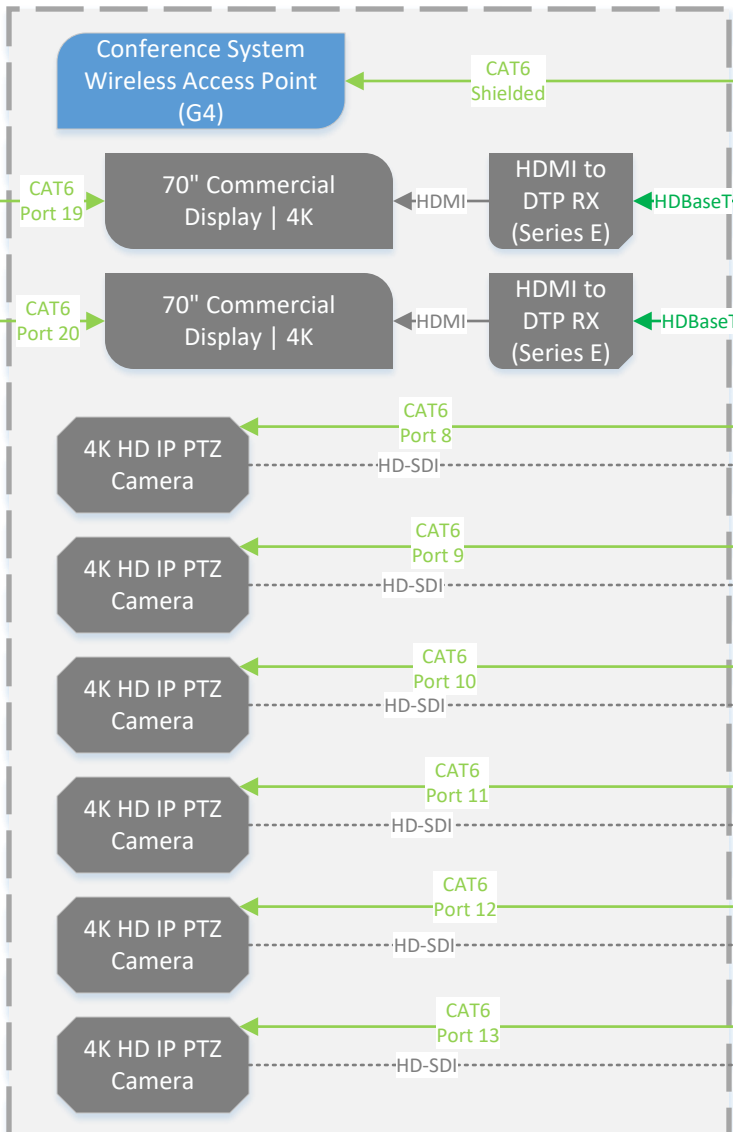

Control Room Desk

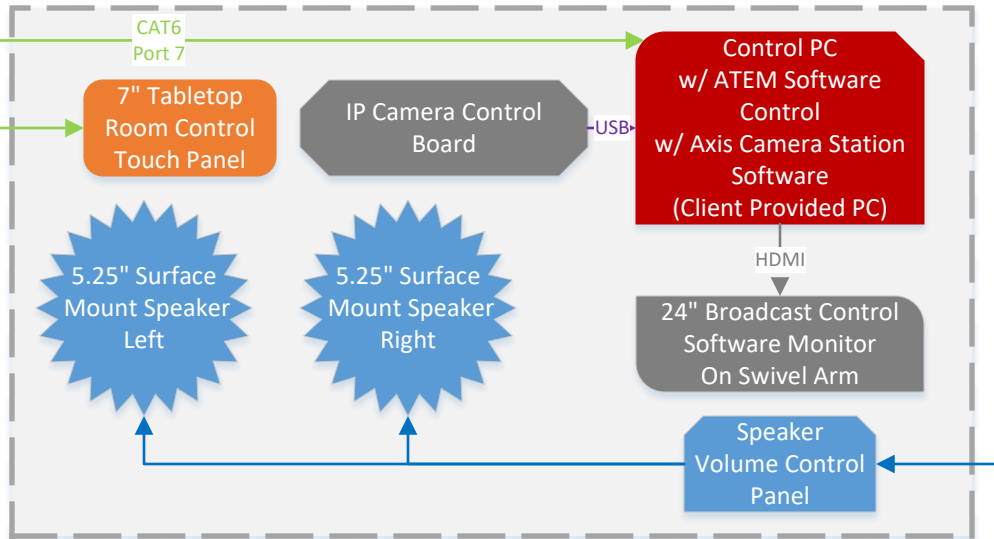

Control Room Rack

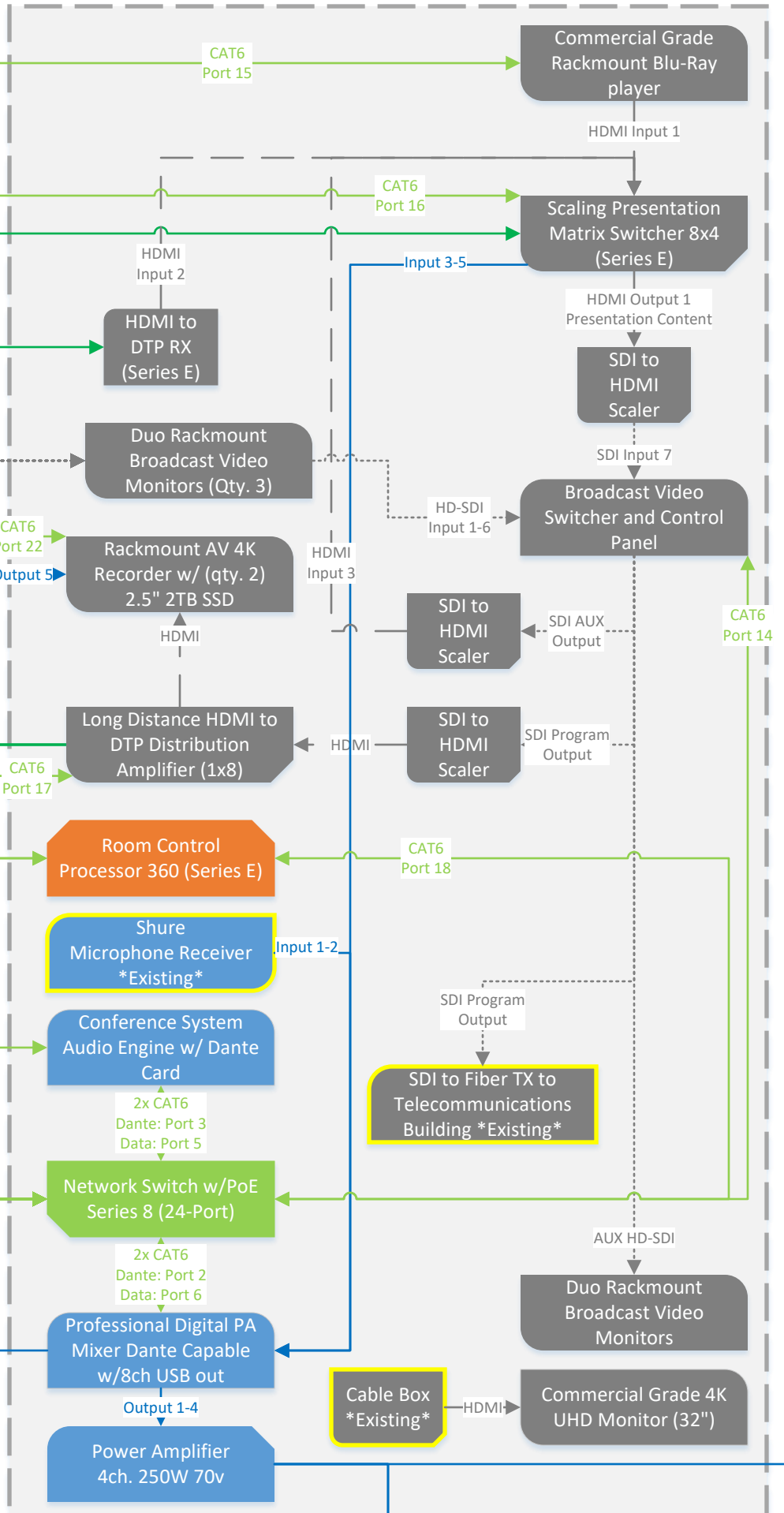

Wall

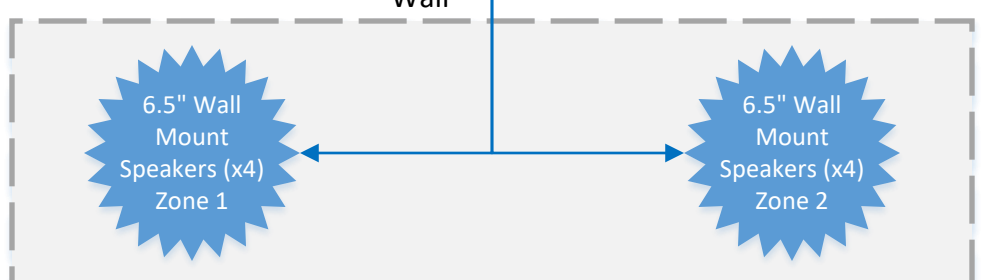

Wiring Legend:

- Audio:
- HDMI:
- VGA:
- Composite:
- Network:
- USB:
- HDBaseT:

Clients Existing Equipment

Signature: _____ Date: _____

<p>ALL IDEAS, DESIGNS AND PLANS REPRESENTED BY THIS DRAWING ARE OWNED BY AND ARE THE PROPERTY OF BISDIGITAL. THEY WERE CREATED AND DEVELOPED FOR USE ON THIS SPECIFIED PROJECT ONLY. NONE OF THE IDEAS, DESIGNS AND PLANS SHALL BE USED BY ANY PERSONS OR CORPORATIONS FOR ANY PURPOSE WITHOUT THE WRITTEN CONSENT OF BISDIGITAL.</p>	<p>BISDIGITAL 1300 NE 58th STREET, SUITE 300 FORT LAUDERDALE, FL 33334 PHONE: 800.715.1234 WEBSITE: www.bisdigital.com</p>	<p>Webb County, TX Q-8023139</p>	
		<p>AV LINE DRAWING</p>	
<p>AUTHOR: M.J.C</p>		<p>DWG NO 1</p>	<p>REV A</p>
<p>DATE: 4.14.2023</p>		<p>SHEET 1 of 1</p>	

Proposal Terms and Conditions

Proposal ID	P-2300207
Effective Period	This proposal is valid through the date required by the requesting organization.
Tax Status	Sales tax will be added to an invoice unless a Tax-Exempt Form is on file with the BIS Digital corporate office.
Payment Terms	Payment for the delivery of goods is due upon the transfer of possession of the goods to the buyer or its agent. Payment of services is due when all services have been fully performed in accordance with the terms of the agreement. The buyer shall promptly inspect the goods or services upon receipt and shall notify BIS Digital of any defects or non-conformities. An ACH number will be provided for payment.
Cancellation	<p>In the event a customer cancels or postpones an order after a deposit has been received, BIS Digital reserves the right to invoice for hardware, software, shipping costs, and any other materials procured for the order.</p> <p>Restocking Fee: A 20% restocking fee will be charged for all canceled orders.</p>
Limited Warranty	New software supplied by BIS Digital are covered for 90 days from the date of installation. New hardware supplied by BIS Digital are covered for 90 days from the date of delivery. Manufacturer Warranties do not cover On-Site Technical Support, Shipping costs, or Software upgrades.
Software Assurance	Annual Software Assurance entitles users to software upgrades at a fixed fee assessed at time of purchase.
Substitutions	Unforeseen supply chain disruptions or component shortages may impact the availability of goods. As a result, some items may require substitution and may be subject to price and/or delivery time variances. In these instances, BIS Digital will consult with the customer about options and alternatives



Proposal Accepted By

Full Name (Print):

Title:

Signature:

Date:

PLEASE NOTE:

By signing above and or providing a purchase order number below, your organization is agreeing to the above pricing, terms, and conditions, and is authorizing BIS Digital, Inc. to order, install, and bill for ALL materials and applicable services listed in this proposal: P-2300207.

Accounts Payable Information

Full Name (Print):

Phone Number:

Email Address:

Fax Number:

Purchase Order Required for Purchasing?

Purchase Order Number:

YES

NO

g. References Form

Please list at minimum five (5) local governmental entities where similar scope of services were provided.

THIS FORM MUST BE RETURNED WITH YOUR OFFER.

REFERENCE ONE

Government/Company Name: Val Verde County Court at Law and Commissioners Court

Address: Del Rio, TX

Contact Person and Title: Ram Barrera, Director of IT; Judge Sergio Gonzalez, County Court at Law

Phone: Ram - 830.282.0153

Fax: _____

Email Address: RGBarrera@valverdecountry.texas.gov

Contract Period: 2013 - Present

SGonzalez@valverdecountry.texas.gov

Description of Professional Services Provided: _____

CCAL - Full System including room control system, microphones, assisted listening system, cameras, Cynap, video conferencing, video displays and switching, DCR recording software, on-site support plan

Commissioners Court - Full System including microphones, cameras, Cynap, video switching, video conferencing, broadcasting, DCR recording software, on-site support plan. We've also provided this client with a mobile system for audio, video, and recording.

REFERENCE TWO

Government/Company Name: Panola County Court, District Court

Address: Carthage, TX

Contact Person and Title: Barry Tate, IT Administrator

Phone: 903.261.7864

Fax: _____

Email Address: itadmin@co.panola.tx.us

Contract Period: 2015 - Present

Description of Professional Services Provided: _____

Full System including room control system, microphones, sound system, cameras, Cynap, video conferencing, video displays and switching, video conferencing, DCR recording software, on-site support plan

REFERENCE THREE

Government/Company Name: 1st and 14th Courts of Appeals

Address: Houston, TX

Contact Person and Title: Christopher Prine, District Clerk

Phone: _____ Fax: _____

Email Address: christopher.prine@txcourts.gov Contract Period: 2019 - Present

Description of Professional Services Provided: _____

Full System including room control system, sound system, assisted listening system, cameras, Cynap, DCR recording software

REFERENCE Four

Government/Company Name: Eules, TX Municipal Court

Address: Eules, TX

Contact Person and Title: Claudia Quintero, Court Manager

Phone: 817-685-1466 Fax: _____

Email Address: cquintero@eulesstx.gov Contract Period: 2/2023 - Present

Description of Professional Services Provided: _____

Full System including room control system, microphones, sound system, Video display and switching, DCR recording software

REFERENCE Five

Government/Company Name: Wylie, TX Municipal Court

Address: Wylie, TX

Contact Person and Title: Lisa Mangham, Court Administrator

Phone: 972.429.8081 Fax: _____

Email Address: Lisa.Mangham@wylietx.gov Contract Period: 2019 - Present

Description of Professional Services Provided: _____

Full System including room microphones, video display and switching, video conferencing, intercom system, DCR recording software

- ****Additional pages are permitted if more space is required****

Space intentionally left Blank

h.3. Support and Service Overview

At BIS Digital, we are committed to meeting our customers' service and support requirements and honoring all product warranties. We also offer comprehensive maintenance programs that include on-site and remote support, service, and training in addition to warranty fulfillment. Complete details are available upon request.

We have a 24/7 toll-free service hotline staffed by experienced technical service representatives, as well as options for placing service calls directly on our website or by phone. In most cases, we can resolve issues over the phone or in a video conference, but there may be times when an on-site visit is necessary. We use hosted customer relationship management (CRM) software to track the performance of our supported systems and our customers' services. Our technicians receive service calls through our internal service coordinator, and the cost of service coverage depends on the customer's service agreement. When a service call is completed, an automated email is sent to the customer with the results.

To ensure that we're responding quickly and efficiently to our customer requests and service issues, we've also implemented a Service Level Management Escalation Policy that outlines how we handle different levels of severity and how we communicate with our customers. Sometimes, we may need to escalate issues for technical or managerial reasons. Technical escalations involve bringing in additional expertise to resolve technical problems as quickly as possible, while managerial escalations involve higher levels of decision-making authority.

To optimize these systems, we ask every customer to contact the Technical Support Center first:

(800) 715-1234
Support@BISDigital.com

Annual support contracts are optional, are calculated as a percentage of the covered equipment, and are offered in three tiers - On-Site WITH Hardware Replacement, On-Site WITHOUT Hardware Replacement, and Remote WITHOUT Hardware Replacement. The annual pricing for these contracts as they specifically relate to the equipment included in the above price quote, pre-discount, are as follows:

On-Site WITH Hardware Replacement:	\$22,906.80 Annually
On-Site WITHOUT Hardware Replacement:	\$19,089.00 Annually
Remote WITHOUT Hardware Replacement:	\$11,453.40 Annually

vSolution Cynap Pro

Wireless presentation, web conferencing & collaboration



Collaborative working & learning – In-person, remote and hybrid



Cynap Pro is a wireless presentation, web conferencing and collaboration system, providing wireless screen sharing for all iOS, Android, Windows, macOS, and Chrome OS devices, together with a unique set of web conferencing and collaboration tools.

The ideal centrepiece for modern classrooms, meeting spaces and courtrooms, this easy-to-use, all-in-one, AV appliance includes the new Cynap multi-platform web conferencing solution, which runs directly on a Cynap. It is designed to solve the issues most commonly experienced with BYOM web conferencing systems.

Zoom, Microsoft Teams and other web conferencing sessions all benefit from the seamless inclusion of multi-screen content from Microsoft 365, the built-in media player, web browser, or whiteboard, ensuring an outstanding, flexible, consistent, collaborative working experience for all – whether participants are in-person, remote-located, or a hybrid combination of both.

Cynap Pro also acts as the 'main station' for our popular vSolution MATRIX AV over IP multi-screen collaboration solution.

Driving Knowledge Creation.

Our Vision

When you've got something to say, we believe it is important that getting your message across and making an impact should be as easy as possible.

Our aim is to help you to explain it better, to give you the freedom to share your knowledge and collaborate with others - however you want, and whenever you want, when your audience is in the same room or on the other side of the world.

**Because knowledge matters -
to all of us.**



System advantages

No apps, no dongles, no cables, no hassle!



Support for AirPlay, Miracast, and Chromecast screen mirroring means no apps, buttons, dongles or extra software are needed when sharing content on-screen from any smartphone, laptop or tablet.

Implementation advantages

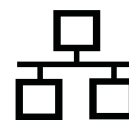

The ability to configure three separate networks (ie. BYOD WiFi, control and admin, and internet service, offers significant advantages when planning your working and learning environments.

Best of both worlds connectivity!



Multi-source wireless screen sharing makes working together easier than ever before. For classroom, meeting space or courtroom installations that require additional connectivity options, two HDMI In ports, are also included, ideal for connecting an in-room PC, Visualizer or camera, etc.

Display & share your files easily



Share your data on-screen easily from connected network drives, mobile devices or by using the Microsoft 365 interface. Even your laptop is no longer essential – simply bring your content on a USB stick, or download it directly from the cloud!

Webcasting: Efficient knowledge sharing



Stream content easily for live or on-demand viewing. Additionally, students or work colleagues on the same network as the presenter can receive and record a stream of on-screen content on their own mobile devices.

Remote management & administration

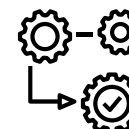

Our vSolution Link Pro software is supplied free of charge facilitating easy remote setup, monitoring, management, and updating of multiple systems across multiple locations.



Flexible connectivity options

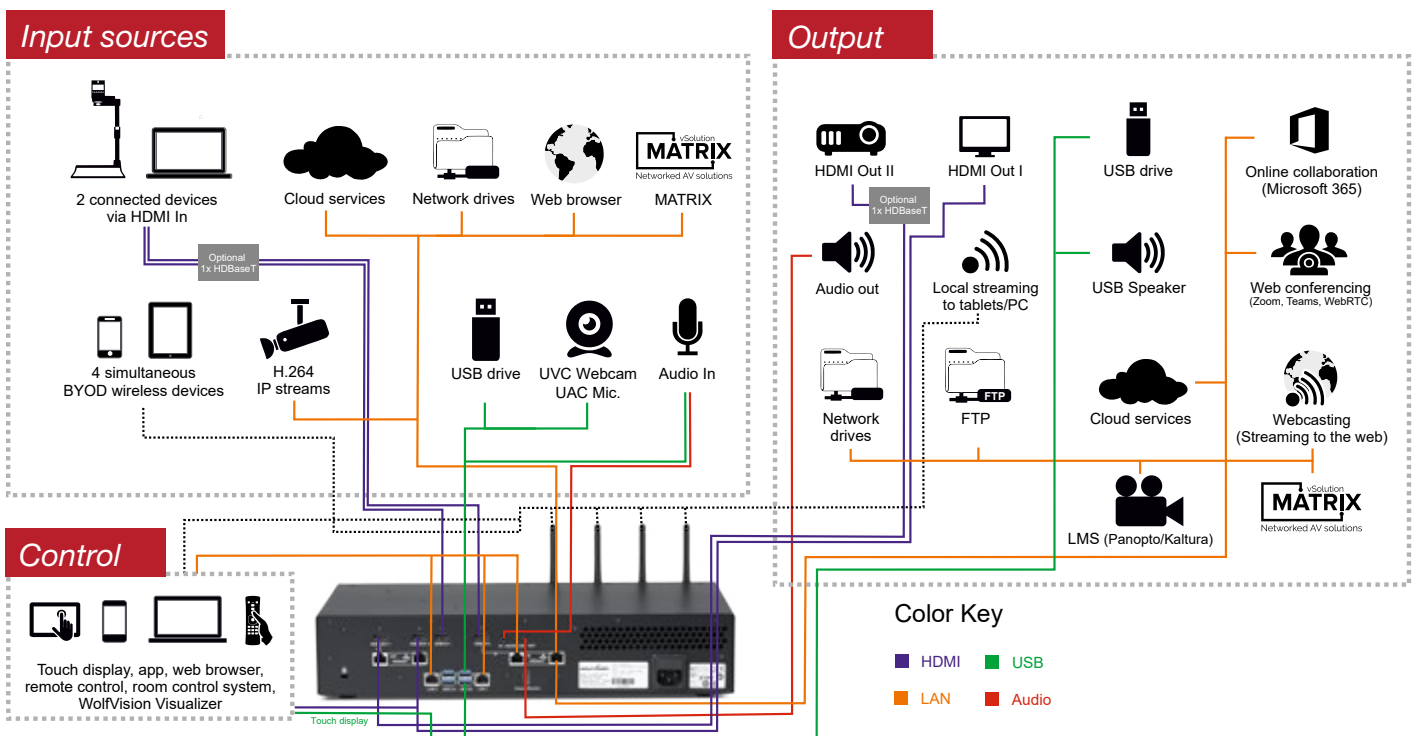



Staying connected in the hybrid world

Multi-platform web conferencing

Cynap Pro's multi-platform web conferencing solution runs directly on the device itself, and is designed to solve many of the issues most commonly experienced with BYOM web conferencing systems.

Complex multi-step setup, and bandwidth issues are eliminated, and Zoom, MS Teams or WebRTC-based wireless conferencing sessions are easily star-

ted and controlled, using a simple workflow, from a touchscreen, or any laptop, smartphone, or tablet.

Web conferencing sessions benefit from the easy inclusion of content from Microsoft 365, the built-in media player, web browser, or whiteboard, ensuring a flexible, consistent, hybrid working and learning working experience for all participants.



Flexible collaboration!

Microsoft 365 integration

Use your active Microsoft 365 account to log in and collaborate together on documents directly via Cynap Pro. Content from Word, PowerPoint, Excel, Outlook, Microsoft Teams, and OneNote can be easily combined with other multi-source materials on-screen using Cynap Pro.



Whiteboard and annotation

Highlight your content material using our easy-to-use annotation features, or add your own handwritten content using the built-in digital whiteboard. The whiteboard includes a collection of easy-to-use writing and drawing tools. It also includes a mind map feature, and the ability to pin content from a connected Visualizer or camera to the screen.

Capture your on-screen content

Easily record on-screen content locally together with video from a connected room camera, or use Cynap Pro as a capture device for Panopto, and other compatible video management platforms.



Technical specifications

Operating system	Linux
Output resolution	2160p60, 2160p30, 1080p60
Supported devices for mirroring (up to 4K depending on device)	iOS, iPadOS, Android, Windows, macOS, Chrome OS
Supported mirroring protocols	AirPlay, Miracast, Chromecast, vSolution Cast
Bluetooth device discovery	Yes (device discovery for environments where Bonjour/mDNS is disabled)
Touchback functionality	Yes, for Windows devices (Miracast & vSolution Cast)
vSolution MATRIX compatible	Yes (main station via optional feature pack, or client)
vSolution Link Pro software for remote management	Yes, Included for Windows 10, Windows Server (2012R2, 2016), Windows Web Server, macOS
Media Player: Supported image file formats	GIF, JPEG, BMP, PNG
Media Player: Supported document file formats	PDF, Word, PowerPoint, Excel, Text, HTML
Media Player: Supported video file formats	AVI, WMV, MOV, MP4, DivX, MKV, M4V, OGV
Media Player: Supported audio file formats	MP3, WMA, MKA, OGA, OGG
Digital signage player	Yes
Max. no. of on-screen windows	4
Dual screen function	Yes
Local streaming	Yes (Unicast/ Multicast), RTP, RTSP
Webcasting to Wowza, YouTube, Facebook, and others	Yes
Local video recording	Yes, selectable up to 1080pFHD, 30fps, .mp4 file format
Capture Agent	Yes, for Panopto, & other compatible video management platforms
Cloud services	Yes, Google Drive, Dropbox, Box, Jianguoyun, OneDrive, WebDAV
Microsoft 365 integration	Yes (current Microsoft 365 account required)
Access to network drives	Yes
Whiteboard and annotation	Yes
Protected/Open presentation modes	Yes
Web conferencing support	Zoom, Microsoft Teams, WebRTC
Encrypt and save personal user settings	Yes, save onto USB stick
Integrated web browser	Yes, with customisable homepage, bookmarks and screensaver
Customisable background image	Yes
Inputs/Outputs	2x HDMI Out (with HDCP 1.4), 1x HDMI Out for control monitor (future use), 2x HDMI In (with HDCP 1.4), Rear: 4x USB 3.0, Front: 2x USB 2.0, Audio via HDMI In/Out, USB In/Out, Line In / Line Out (unbalanced 3.5mm), 2x 1GigE LAN ports. Optional: Additional HDMI In via USB framegrabber (third party)
HDBaseT 1.0 input	Optional x1 (can be used only when HDMI input 2 is not in use)
HDBaseT 1.0 output	Optional x1 (can be used only when HDMI output 1 is not in use)
Wifi standards (Wi-Fi 5)	2.4 and 5 GHz
Network protocols	TCP/IP, FTP, HTTP, HTTPS, SNT/NT, SSL, SSH, UDP, LDAP, LDAPS
IP configuration	DHCP, Static (IP address, Subnet mask, Default gateway, DNS server), Proxy, Interface priority
Security authentication for LAN	IEEE 802.1X
Security encryption for WLAN	WEP, WPA2, WPA2 Enterprise or IEEE 802.1X
RMS encryption	Yes
External controlling	Remote control with gyro sensor function, web interface, Visualizer, multi-touch display, room control system, USB keyboard and mouse
Dimensions (L x W x H) / Weight	428 x 218.7 x 88.2mm (16.85 x 8.6 x 3.47") / 4.5kg (9.9lb)
Power consumption	Max. 105W
Included accessories	Power cable, antennas, rackmount/table mount kit, voucher for remote control
Limited warranty / Made in	3 years (optional warranty extension up to 5 years) / EU/Austria



Remote control

Your WolfVision Partner:

Brandy Johnson
brandy.johnson@bisdigital.com
830.388.0134



More information:

WOLFVISION
www.wolfvision.com

Head Office:

WolfVision GmbH
6833 Klaus / Austria
Tel. +43 5523 52250
wolfvision@wolfvision.com

Japan Sales Office
WolfVision Co. Ltd.
Tel. +81 3 6233 9465
wolfvision.japan@wolfvision.com

USA Sales Office
WolfVision, Inc.
Tel. +1 770 931 6802
sales@wolfvision.us

Nordic Sales Office
WolfVision Nordic (Norway)
Tel. +47 9186 9736
wolfvision.nordic@wolfvision.net

UK Sales Office
WolfVision UK Ltd.
Tel. +44 1628 968660
wolfvision.uk@wolfvision.com

Middle East Sales Office
WolfVision Middle East (Dubai)
Tel. +971 5617 40008
wolfvision.mideast@wolfvision.com

Asia Sales Office
WolfVision Pte. Ltd. (Singapore)
Tel. +65 6636 1268
wolfvision.asia@wolfvision.net

Germany Sales Office
WolfVision GmbH
Tel. 0800 9828 787
wolfvision.deutschland@wolfvision.com



The Televic Confidea GO G4 is an impressive microphone offering a sleek and sturdy alloy of zinc and aluminum design, offering mute function and LED indicator, as well as individual audio speakers and headphone jacks for those that may need an extra volume boost.

h.1. Installation Overview

BIS Digital is committed to delivering high-quality AV systems that meet the needs of our clients; our installation process is an integral part of this commitment. The following section is a general overview of the steps we take to ensure a seamless experience. Note: The final schedule is determined with the client after a proposal is accepted and a purchase order is received.

Our installation process begins with careful planning and design to ensure that the AV system meets the needs of the end users and is properly integrated into the space. This includes conducting site surveys to assess the physical space and infrastructure, as well as working with clients to understand their specific needs and requirements. In circumstances where we are not able to conduct a technical walkthrough pre-quotation or believe the project would benefit from an additional review, we will coordinate a site survey at the client's earliest convenience. This allows us to properly assess the physical space and infrastructure, and solidify whether any site preparations need to be made in advance, such as providing lockable storage or installing power outlets as needed to support the AV system. Product orders will commence immediately following this final site review meeting and can take 2-3 weeks, depending on manufacturing and shipping times.

Once the site is prepared, BIS Digital will connect and configure all hardware and software components of the AV system. All work will be performed by BIS Digital Technicians only, with no subcontractors. This may include installing and configuring audio processors, amplifiers, and control systems, as well as integrating the AV system with other building systems as applicable. Installation times can range from two days to two weeks per room depending upon the complexity of the system and environment. Custom programming and support will be provided by BIS Digital programmers, who will be available throughout the installation period and for routine performance upgrades and maintenance through remote service. BIS Digital follows all local building codes and regulations when performing work and ensures that all components are installed safely and securely.

After all elements are installed and tested, our technicians will provide user training to ensure that all end users are comfortable operating the AV system. The scope of training will vary depending on the complexity of the project and the number of users who need to be trained. This may include hands-on training sessions, demonstrations, and the creation of user manuals or other documentation as needed. Ongoing training can also be provided through an on-site service or remote service agreement if desired. Our goal is to ensure that all end users have the knowledge and skills they need to effectively use and maintain the AV system.

THIS FORM MUST BE INCLUDED WITH RFP PACKAGE; PLEASE CHECK OFF EACH ITEM INCLUDED WITH RFP PACKAGE AND SIGN BELOW TO COMPLETE SUBMITTAL / COMPLETION OF EACH REQUIRED ITEM.

**RFP 2023-007
ARPA Project No. 16
Audio/Video Broadcasting Equipment/Streaming Services
for County Courthouse**

- References Form
- Conflict of Interest Form (CIQ)
- Certification regarding Debarment (Form H2048)
- Certification regarding Federal lobbying (Form 2049)
- Code of Ethics Affidavit
- House Bill 89 Form
- Senate Bill 252 Form
- SAMs Registration completed by Offeror (**See Section 1.13**)
- Proof of No Delinquent Tax Owed to Webb County
- Insurance Requirements
- FCC Notices (Exhibit A, Exhibit B)

Brandy Johnson

Signature of Person Completing this Package

4/25/23

Date

References Form

Please list at minimum five (5) local governmental entities where similar scope of services were provided.

THIS FORM MUST BE RETURNED WITH YOUR OFFER.

REFERENCE ONE

Government/Company Name: Val Verde County Court at Law and Commissioners Court

Address: Del Rio, TX

Contact Person and Title: Ram Barrera, Director of IT; Judge Sergio Gonzalez, County Court at Law

Phone: Ram - 830.282.0153

Fax: _____

Email Address: RGBarrera@valverdecountry.texas.gov

Contract Period: 2013 - Present

SGonzalez@valverdecountry.texas.gov

Description of Professional Services Provided: _____

CCAL - Full System including room control system, microphones, assisted listening system, cameras, Cynap, video conferencing, video displays and switching, DCR recording software, on-site support plan

Commissioners Court - Full System including microphones, cameras, Cynap, video switching, video conferencing, broadcasting, DCR recording software, on-site support plan. We've also provided this client with a mobile system for audio, video, and recording.

REFERENCE TWO

Government/Company Name: Panola County Court, District Court

Address: Carthage, TX

Contact Person and Title: Barry Tate, IT Administrator

Phone: 903.261.7864

Fax: _____

Email Address: itadmin@co.panola.tx.us

Contract Period: 2015 - Present

Description of Professional Services Provided: _____

Full System including room control system, microphones, sound system, cameras, Cynap, video conferencing, video displays and switching, video conferencing, DCR recording software, on-site support plan

REFERENCE THREE

Government/Company Name: 1st and 14th Courts of Appeals

Address: Houston, TX

Contact Person and Title: Christopher Prine, District Clerk

Phone: _____ Fax: _____

Email Address: christopher.prine@txcourts.gov Contract Period: 2019 - Present

Description of Professional Services Provided: _____

Full System including room control system, sound system, assisted listening system, cameras, Cynap,

DCR recording software

REFERENCE Four

Government/Company Name: Eules, TX Municipal Court

Address: Eules, TX

Contact Person and Title: Claudia Quintero, Court Manager

Phone: 817-685-1466 Fax: _____

Email Address: cquintero@eulesstx.gov Contract Period: 2/2023 - Present

Description of Professional Services Provided: _____

Full System including room control system, microphones, sound system, Video display and switching,

DCR recording software

REFERENCE Five

Government/Company Name: Wylie, TX Municipal Court

Address: Wylie, TX

Contact Person and Title: Lisa Mangham, Court Administrator

Phone: 972.429.8081 Fax: _____

Email Address: Lisa.Mangham@wylietx.gov Contract Period: 2019 - Present

Description of Professional Services Provided: _____

Full System including room microphones, video display and switching, video conferencing, intercom system, DCR recording software

- ****Additional pages are permitted if more space is required****

Space intentionally left Blank

CONFLICT OF INTEREST QUESTIONNAIRE
For vendor doing business with local governmental entity

FORM CIQ

This questionnaire reflects changes made to the law by H.B. 23, 84th Leg., Regular Session.
This questionnaire is being filed in accordance with Chapter 176, Local Government Code, by a vendor who has a business relationship as defined by Section 176.001(1-a) with a local governmental entity and the vendor meets requirements under Section 176.006(a).
By law this questionnaire must be filed with the records administrator of the local governmental entity not later than the 7th business day after the date the vendor becomes aware of facts that require the statement to be filed. See Section 176.006(a-1), Local Government Code.
A vendor commits an offense if the vendor knowingly violates Section 176.006, Local Government Code. An offense under this section is a misdemeanor.

OFFICE USE ONLY

Date Received

1 Name of vendor who has a business relationship with local governmental entity.

BIS Digital

2 Check this box if you are filing an update to a previously filed questionnaire. (The law requires that you file an updated completed questionnaire with the appropriate filing authority not later than the 7th business day after the date on which you became aware that the originally filed questionnaire was incomplete or inaccurate.)

3 Name of local government officer about whom the information is being disclosed.

Not Applicable

Name of Officer

4 Describe each employment or other business relationship with the local government officer, or a family member of the officer, as described by Section 176.003(a)(2)(A). Also describe any family relationship with the local government officer. Complete subparts A and B for each employment or business relationship described. Attach additional pages to this Form CIQ as necessary.

A. Is the local government officer or a family member of the officer receiving or likely to receive taxable income, other than investment income, from the vendor?

Yes No

B. Is the vendor receiving or likely to receive taxable income, other than investment income, from or at the direction of the local government officer or a family member of the officer AND the taxable income is not received from the local governmental entity?

Yes No

5 Describe each employment or business relationship that the vendor named in Section 1 maintains with a corporation or other business entity with respect to which the local government officer serves as an officer or director, or holds an ownership interest of one percent or more.

None

6 Check this box if the vendor has given the local government officer or a family member of the officer one or more gifts as described in Section 176.003(a)(2)(B), excluding gifts described in Section 176.003(a-1).

7 
Signature of vendor doing business with the governmental entity

4/17/23
Date

CERTIFICATION
REGARDING DEBARMENT, SUSPENSION, INELIGIBILITY AND VOLUNTARY
EXCLUSION FOR COVERED CONTRACTS

PART A.

Federal Executive Orders 12549 and 12689 require the Texas Department of Agriculture (TDA) to screen each covered potential contractor to determine whether each has a right to obtain a contract in accordance with federal regulations on debarment, suspension, ineligibility, and voluntary exclusion. Each covered contractor must also screen each of its covered subcontractors.

In this certification "contractor" refers to both contractor and subcontractor; "contract" refers to both contract and subcontract.

By signing and submitting this certification the potential contractor accepts the following terms:

1. The certification herein below is a material representation of fact upon which reliance was placed when this contract was entered into. If it is later determined that the potential contractor knowingly rendered an erroneous certification, in addition to other remedies available to the federal government, the Department of Health and Human Services, United States Department of Agriculture or other federal department or agency, or the TDA may pursue available remedies, including suspension and/or debarment.
2. The potential contractor will provide immediate written notice to the person to which this certification is submitted if at any time the potential contractor learns that the certification was erroneous when submitted or has become erroneous by reason of changed circumstances.
3. The words "covered contract", "debarred", "suspended", "ineligible", "participant", "person", "principal", "proposal", and "voluntarily excluded", as used in this certification have meanings based upon materials in the Definitions and Coverage sections of federal rules implementing Executive Order 12549. Usage is as defined in the attachment.
4. The potential contractor agrees by submitting this certification that, should the proposed covered contract be entered into, it will not knowingly enter into any subcontract with a person who is debarred, suspended, declared ineligible, or voluntarily excluded from participation in this covered transaction, unless authorized by the Department of Health and Human Services, United States Department of Agriculture or other federal department or agency, and/or the TDA, as applicable.

Do you have or do you anticipate having subcontractors under this proposed contract?

Yes

No

5. The potential contractor further agrees by submitting this certification that it will include this certification titled "Certification Regarding Debarment, Suspension, Ineligibility, and Voluntary Exclusion for Covered Contracts" without modification, in all covered subcontracts and in solicitations for all covered subcontracts.
6. A contractor may rely upon a certification of a potential subcontractor that it is not debarred, suspended, ineligible, or voluntarily excluded from the covered contract, unless it knows that the certification is erroneous. A contractor must, at a minimum, obtain certifications from its covered subcontractors upon each subcontract's initiation and upon each renewal.
7. Nothing contained in all the foregoing will be construed to require establishment of a system of records in order to render in good faith the certification required by this certification document. The knowledge and information of a contractor is not required to exceed that which is normally possessed by a prudent person in the ordinary course of business dealings.
8. Except for contracts authorized under paragraph 4 of these terms, if a contractor in a covered contract knowingly enters into a covered subcontract with a person who is suspended, debarred, ineligible, or voluntarily excluded from participation in this transaction, in addition to other remedies available to the federal government, Department of Health and Human Services, United States Department of Agriculture, or other federal department or agency, as applicable, and/or the TDA may pursue available remedies, including suspension and/or debarment.

PART B. CERTIFICATION REGARDING DEBARMENT, SUSPENSION, INELIGIBILITY AND VOLUNTARY EXCLUSION FOR COVERED CONTRACTS

Indicate in the appropriate box which statement applies to the covered potential contractor:

- The potential contractor certifies, by submission of this certification, that neither it nor its principals is presently debarred, suspended, proposed for debarment, declared ineligible, or voluntarily excluded from participation in this contract by any federal department or agency or by the State of Texas.
- The potential contractor is unable to certify to one or more of the terms in this certification. In this instance, the potential contractor must attach an explanation for each of the above terms to which he is unable to make certification. Attach the explanation(s) to this certification.

Name of Contractor	Vendor ID No. or Social Security No.	Program No.
BIS Digital	59-2210686	

Signature of Authorized Representative

4/17/23
Date

Kirk Ambrose, Vice President
Printed/Typed Name and Title of
Authorized Representative

CERTIFICATION REGARDING FEDERAL LOBBYING
(Certification for Contracts, Grants, Loans, and Cooperative Agreements)

PART A. PREAMBLE

Federal legislation, Section 319 of Public Law 101-121 generally prohibits entities from using federally appropriated funds to lobby the executive or legislative branches of the federal government. Section 319 specifically requires disclosure of certain lobbying activities. A federal government-wide rule, "New Restrictions on Lobbying", published in the Federal Register, February 26, 1990, requires certification and disclosure in specific instances.

PART B. CERTIFICATION

This certification applies only to the instant federal action for which the certification is being obtained and is a material representation of fact upon which reliance was placed when this transaction was made or entered into. Submission of this certification is a prerequisite for making or entering into this transaction imposed by section 1352, title 31, U.S. Code. Any person who fails to file the required certification shall be subject to a civil penalty of not less than \$100,000 for each such failure.

The undersigned certifies, to the best of his or her knowledge and belief, that:

1. No federally appropriated funds have been paid or will be paid, by or on behalf of the undersigned, to any person for influencing or attempting to influence an officer or employee of any agency, a member of Congress, an officer or employee of Congress, or an employee of a member of Congress in connection with the awarding of any federal contract, the making of any federal grant, the making of any federal loan, the entering into of any cooperative agreement, or the extension, continuation, renewal, amendment, or modification of any federal contract, grant, loan, or cooperative agreement.
2. If any funds other than federally appropriated funds have been paid or will be paid to any person for influencing or attempting to influence an officer or employee of any agency, a member of Congress, an officer or employee of Congress, or an employee of a member of Congress in connection with these federally funded contract, subcontract, subgrant, or cooperative agreement, the undersigned shall complete and submit Standard Form-LLL, "Disclosure Form to Report Lobbying", in accordance with its instructions. (If needed, contact the Texas Department of Agriculture to obtain a copy of Standard Form-LLL.)

3. The undersigned shall require that the language of this certification be included in the award documents for all covered subawards at all tiers (including subcontracts, subgrants, and contracts under grants, loans, and cooperative agreements) and that all covered subrecipients will certify and disclose accordingly.

Do you have or do you anticipate having covered subawards under this transaction?

Yes

No

Name of Contractor/Potential Contractor	Vendor ID No. or Social Security No.	Program No.
BIS Digital	EQ-2210686	

Name of Authorized Representative	Title
Kirk Ambrose	Vice President

Signature – Authorized Representative

4/17/23
Date

**WEBB COUNTY PURCHASING DEPT.
QUALIFIED PARTICIPATING VENDOR CODE OF ETHICS
AFFIDAVIT FORM**

STATE OF TEXAS *

KNOW ALL MEN BY THESE PRESENTS:

COUNTY OF WEBB *

BEFORE ME the undersigned Notary Public, appeared Kirk Ambrose, the herein-named "Affiant", who is a resident of Broward County, State of Florida, and upon his/her respective oath, either individually and/or behalf of their respective company/entity, do hereby state that I have personal knowledge of the following facts, statements, matters, and/or other matters set forth herein are true and correct to the best of my knowledge.

I personally, and/or in my respective authority/capacity on behalf of my company/entity do hereby confirm that I have reviewed and agree to fully comply with all the terms, duties, ethical policy obligations and/or conditions as required to be a qualified participating vendor with Webb County, Texas as set forth in the Webb County Purchasing Code of Ethics Policy posted at the following address: <http://www.webbcountytx.gov/PurchasingAgent/PurchasingEthicsPolicy.pdf>

I personally, and/or in my respective authority/capacity on behalf of my company/entity do hereby further acknowledge, agree and understand that as a participating vendor with Webb County, Texas on any active solicitation/proposal/qualification that I and/or my company/entity failure to comply with the Code of Ethics policy may result in my and/or my company/entity disqualification, debarment or make void my contract awarded to me, my company/entity by Webb County. I agree to communicate with the Purchasing Agent or his designees should I have questions or concerns regarding this policy to ensure full compliance by contacting the Webb County Purchasing Dept. via telephone at (956) 523-4125 or e-mail to the Webb County Purchasing Agent to joel@webbcountytx.gov.

Executed and dated this 17 day of April, 2023.

Signature of Affiant

Kirk Ambrose
Printed Name of Affiant/Company/Entity

SWORN to and subscribed before me, this 17th day of April, 2023

NOTARY PUBLIC, STATE OF TEXAS

Notary Public State of Florida
Bridgit L. Watkins
My Commission GG 355816
Expires 07/18/2023

Offeror: Complete & Return this Form with Response Submission.

House Bill 89 Verification

I, Kirk Ambrose, the undersigned representative of (company or business name) BIS Digital (heretofore referred to as company) being an adult over the age of eighteen (18) years of age, after being duly sworn by the undersigned notary, do hereby depose and verify under oath that the company named above, under the provisions of Subtitle F, Title 10, Government Code Chapter 2270:

1. Does not boycott Israel currently; and
2. Will not boycott Israel during the term of the contract.

Pursuant to Section 2270.001, Texas Government Code:

1. "Boycott Israel" means refusing to deal with, terminating business activities with, or otherwise taking any action that is intended to penalize, inflict economic harm on, or limit commercial relations specifically with Israel, or with a person or entity doing business in Israel or in an Israeli-controlled territory, but does not include an action made ordinary business purposes; and

2. "Company" means a for-profit sole proprietorship, organization, association, corporation, partnership, joint venture, limited partnership, limited liability partnership, or an limited liability company, including a wholly owned subsidiary, majority-owned subsidiary, parent company or affiliate of those entities or business association that exist to make a profit.

Signature of Company Representative

4/17/23
Date

On this 17th day of APRIL, 2023, personally appeared

KIRK AMBROSE, the above named person, who after by me being duly sworn, did swear and confirm that the above is true and correct.

Notary Seal 
Notary Signature

04/17/23
Date

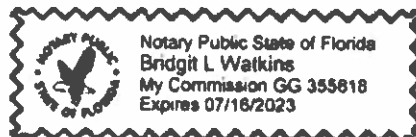

**Offeror: Complete & Return this Form with Response Submission.
Senate Bill 252 Certification**

SB 252 CHAPTER 2252 CERTIFICATION I, Kirk Ambrose, the undersigned representative of BIS Digital (Company or business name) being an adult over the age of eighteen (18) years of age, pursuant to Texas Government Code, Chapter 2252, Section 2252.152 and Section 2252.153, certify that the company named above is not listed on the website of the Comptroller of the State of Texas concerning the listing of companies that are identified under Section 806.051, Section 807.051 or Section 2253.153. I further certify that should the above-named company enter into a contract that is on said listing of companies on the website of the Comptroller of the State of Texas which do business with Iran, Sudan or any Foreign Terrorist Organization, I will immediately notify Mr. Jose Angel Lopez III, Webb County Purchasing Agent at (956) 523-4125 or via email at joel@webbcountytx.gov

Kirk Ambrose Name of Company Representative (Print)

 Signature of Company Representative

4/17/23 Date

Sam.gov Information

BUSINESS INFORMATION SYSTEMS INC ● Active Registration

Unique Entity ID:
L443F978GK46

Doing Business As:
(blank)

Purpose of Registration:
All Awards

CAGE/NCAGE:
1P1G3

Physical Address:
**1350 NE 56TH ST, #300
FORT LAUDERDALE, FL 33334-
6142 USA**

PROOF OF NO DELINQUENT TAXES OWED TO WEBB COUNTY

Name BIS Digital owes no delinquent property taxes to Webb County.

BIS Digital owes no property taxes as a business in Webb County.
(Business Name)

Steve Coldren owes no property taxes as a resident of Webb County.
(Business Owner)

Kirk Ambrose
Person who can attest to the above information

*** SIGNED NOTORIZED DOCUMENT AND PROOF OF NO DELINQUENT TAXES TO WEBB COUNTY.**

The State of Texas
County of Webb

Before me, a Notary Public, on this day personally appeared KIRK AMBROSE, know to me (or proved to me on the oath of (PERSONALLY KNOWN) to be the person whose name is subscribed to the forgoing instrument and acknowledged to me that he executed the same for the purpose and consideration therein expressed.

Given under my hand and seal of office this 17th day of APRIL 2023.

Notary Public, State of Texas



Bridgit L. Watkins

(Print name of Notary Public here)

My commission expires the ___ day of ___ 20__.



CERTIFICATE OF LIABILITY INSURANCE

DATE (MM/DD/YYYY)

4/13/2023

THIS CERTIFICATE IS ISSUED AS A MATTER OF INFORMATION ONLY AND CONFERS NO RIGHTS UPON THE CERTIFICATE HOLDER. THIS CERTIFICATE DOES NOT AFFIRMATIVELY OR NEGATIVELY AMEND, EXTEND OR ALTER THE COVERAGE AFFORDED BY THE POLICIES BELOW. THIS CERTIFICATE OF INSURANCE DOES NOT CONSTITUTE A CONTRACT BETWEEN THE ISSUING INSURER(S), AUTHORIZED REPRESENTATIVE OR PRODUCER, AND THE CERTIFICATE HOLDER.

IMPORTANT: If the certificate holder is an ADDITIONAL INSURED, the policy(ies) must have ADDITIONAL INSURED provisions or be endorsed. If SUBROGATION IS WAIVED, subject to the terms and conditions of the policy, certain policies may require an endorsement. A statement on this certificate does not confer rights to the certificate holder in lieu of such endorsement(s).

PRODUCER License # L096220 JAG Insurance Group, LLC 999 Ponce De Leon Blvd Suite 800 Coral Gables, FL 33134	CONTACT NAME: ernoon PHONE (A/C, No, Ext): (305) 842-3600 FAX (A/C, No): (305) 842-3600	
	E-MAIL ADDRESS: 	
INSURER(S) AFFORDING COVERAGE		NAIC #
INSURER A : TRAVELERS INSURANCE COMPANY		36137
INSURER B :		
INSURER C :		
INSURER D :		
INSURER E :		
INSURER F :		

INSURED

Business Information Systems, Inc.
 1350 NE 56 Street #300
 Fort Lauderdale, FL 33334

COVERAGES

CERTIFICATE NUMBER:

REVISION NUMBER:

THIS IS TO CERTIFY THAT THE POLICIES OF INSURANCE LISTED BELOW HAVE BEEN ISSUED TO THE INSURED NAMED ABOVE FOR THE POLICY PERIOD INDICATED. NOTWITHSTANDING ANY REQUIREMENT, TERM OR CONDITION OF ANY CONTRACT OR OTHER DOCUMENT WITH RESPECT TO WHICH THIS CERTIFICATE MAY BE ISSUED OR MAY PERTAIN, THE INSURANCE AFFORDED BY THE POLICIES DESCRIBED HEREIN IS SUBJECT TO ALL THE TERMS, EXCLUSIONS AND CONDITIONS OF SUCH POLICIES. LIMITS SHOWN MAY HAVE BEEN REDUCED BY PAID CLAIMS.

INSR LTR	TYPE OF INSURANCE	ADDL INSD	SUBR WVD	POLICY NUMBER	POLICY EFF (MM/DD/YYYY)	POLICY EXP (MM/DD/YYYY)	LIMITS
A	<input checked="" type="checkbox"/> COMMERCIAL GENERAL LIABILITY <input type="checkbox"/> CLAIMS-MADE <input checked="" type="checkbox"/> OCCUR GEN'L AGGREGATE LIMIT APPLIES PER: <input checked="" type="checkbox"/> POLICY <input type="checkbox"/> PRO-JECT <input type="checkbox"/> LOC OTHER:			ZPP61N1861722	9/15/2022	9/15/2023	EACH OCCURRENCE \$ 1,000,000 DAMAGE TO RENTED PREMISES (Ea occurrence) \$ 300,000 MED EXP (Any one person) \$ 10,000 PERSONAL & ADV INJURY \$ 1,000,000 GENERAL AGGREGATE \$ 2,000,000 PRODUCTS - COMP/OP AGG \$ 2,000,000 \$
	AUTOMOBILE LIABILITY <input type="checkbox"/> ANY AUTO OWNED AUTOS ONLY <input type="checkbox"/> HIRED AUTOS ONLY <input type="checkbox"/> SCHEDULED AUTOS <input type="checkbox"/> NON-OWNED AUTOS ONLY						COMBINED SINGLE LIMIT (Ea accident) \$ BODILY INJURY (Per person) \$ BODILY INJURY (Per accident) \$ PROPERTY DAMAGE (Per accident) \$ \$
A	<input checked="" type="checkbox"/> UMBRELLA LIAB <input checked="" type="checkbox"/> OCCUR <input type="checkbox"/> EXCESS LIAB <input type="checkbox"/> CLAIMS-MADE DED <input checked="" type="checkbox"/> RETENTION \$ 10,000			CUP9K67518822	9/15/2022	9/15/2023	EACH OCCURRENCE \$ 2,000,000 AGGREGATE \$ Aggregate \$ 2,000,000
A	WORKERS COMPENSATION AND EMPLOYERS' LIABILITY ANY PROPRIETOR/PARTNER/EXECUTIVE OFFICER/MEMBER EXCLUDED? (Mandatory in NH) <input type="checkbox"/> Y / N If yes, describe under DESCRIPTION OF OPERATIONS below		N / A	UB9M41926422	10/1/2022	10/1/2023	<input type="checkbox"/> PER STATUTE <input type="checkbox"/> OTH-ER E.L. EACH ACCIDENT \$ 1,000,000 E.L. DISEASE - EA EMPLOYEE \$ 1,000,000 E.L. DISEASE - POLICY LIMIT \$ 1,000,000
A	Prof.Liab/E&O			ZPL41N1714022	9/15/2022	9/15/2023	Retention \$25K \$ 1,000,000

DESCRIPTION OF OPERATIONS / LOCATIONS / VEHICLES (ACORD 101, Additional Remarks Schedule, may be attached if more space is required)
Cyber Liability (Crisis Management Services Expenses) \$1,000,000.
\$25,000 Retention

CERTIFICATE HOLDER

CANCELLATION

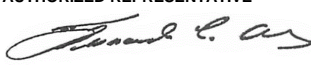
Webb County, TX 1000 Houston Street Laredo, TX 78040	SHOULD ANY OF THE ABOVE DESCRIBED POLICIES BE CANCELLED BEFORE THE EXPIRATION DATE THEREOF, NOTICE WILL BE DELIVERED IN ACCORDANCE WITH THE POLICY PROVISIONS.
	AUTHORIZED REPRESENTATIVE 

BIS Digital acknowledges Exhibit A and
Exhibit B - FCC Notices

Form 1295 will be completed as
required upon acceptance of included
proposal.

County of Webb

ADDENDUM No. 1 TO THE RFP DOCUMENTS

Addendum Date: April 11, 2023

RFP DOCUMENT NUMBER RFP 2023-007

ARPA Project No. 16

“Audio Video Broadcasting Equipment Streaming Services”

A. This Addendum shall be considered part of the RFP documents for the above-mentioned project as though it had been issued at the same time and shall be incorporated integrally therewith. Where provisions of the following supplementary data differ from those of the original bid documents, this Addendum shall govern and take precedence. **RESPONDENTS MUST SIGN THE ADDENDUM AND SUBMIT IT WITH THEIR BIDS/PROPOSALS.**

B. Respondent are hereby notified that they shall make any necessary adjustments in their estimates as a result of this Addendum. It will be construed that each bidder's proposal is submitted with full knowledge of all modifications and supplemental data specified herein.

Except as described below, the original RFP document remains unchanged. The RFP documents are modified and/or clarified, as follows:

- **The Pre-Proposal meeting has been modified and is no longer mandatory. Interested parties will now be able to join via Webex. The link to the meeting has been issued with the link below:**

Join from the meeting link

<https://webbcountytexas.webex.com/webbcountytexas/j.php?MTID=m590448c36f976861dc51b5fe23a11aac>

Join by meeting number

Meeting number (access code): 2465 162 2528

Meeting password: xwJFVPEt882

Tap to join from a mobile device (attendees only)

+1-415-655-0002,,24651622528## US Toll

Join by phone

+1-415-655-0002 US Toll

Global call-in numbers

Join from a video system or application
Dial 24651622528@webbcountytx.webex.com

You can also dial 173.243.2.68 and enter your meeting number.

- **The ARPA Project No. has been revised as follows:**

RFP 2023-007 **ARPA Project No. 16** Audio Video Broadcasting Equipment Streaming Services

RESPONDENT MUST ACKNOWLEDGE THIS ADDENDUM BY SIGNING BELOW AND ATTACHING THE SIGNED ADDENDUM TO THE PROPOSAL FORM(S):

Company Name BIS Digital

Contact Person Brandy Johnson

Signature *Brandy Johnson*

Date 4/25/23

THIS CONCLUDES ADDENDUM NO. 1 IN ITS ENTIRETY.

This Addendum is being transmitted electronically via our E-Bid site @ <https://webbcountyebid.ionwave.net/Login.aspx> . If you have any questions, please direct them to; Juan Guerrero Jr. (956) 523-4149 or email at juguerrero@webbcountytx.gov .

County of Webb

ADDENDUM No. 2 TO THE RFP DOCUMENTS

Addendum Date: April 17, 2023

RFP DOCUMENT NUMBER RFP 2023-007

ARPA Project No. 16

“Audio Video Broadcasting Equipment Streaming Services”

A. This Addendum shall be considered part of the RFP documents for the above-mentioned project as though it had been issued at the same time and shall be incorporated integrally therewith. Where provisions of the following supplementary data differ from those of the original bid documents, this Addendum shall govern and take precedence. **RESPONDENTS MUST SIGN THE ADDENDUM AND SUBMIT IT WITH THEIR BIDS/PROPOSALS.**

B. Respondent are hereby notified that they shall make any necessary adjustments in their estimates as a result of this Addendum. It will be construed that each bidder's proposal is submitted with full knowledge of all modifications and supplemental data specified herein.

Except as described below, the original RFP document remains unchanged. The RFP documents are modified and/or clarified, as follows:

- **Photos of the Webb County Courthouse have been added under the “Attachments” tab in a Zip file by the name *Courthouse Photos*.**

RESPONDENT MUST ACKNOWLEDGE THIS ADDENDUM BY SIGNING BELOW AND ATTACHING THE SIGNED ADDENDUM TO THE PROPOSAL FORM(S):

Company Name BIS Digital

Contact Person Brandy Johnson

Signature 

Date 4/25/2023

THIS CONCLUDES ADDENDUM NO. 2 IN ITS ENTIRETY.

This Addendum is being transmitted electronically via our E-Bid site @ <https://webbcountyebid.ionwave.net/Login.aspx>. If you have any questions, please direct them to; Juan Guerrero Jr. (956) 523-4149 or email at juguerrero@webbcountytx.gov.