



Preliminary Total Project Cost Outline (County ROW)

Webb County: US 59 - SH 359 Connector Project
US 59 to SH 359 (3.5 mi approx.)



Roadway Project	US 59 - SH359 Connector
Limits	
From	US 59
To	SH 359
Roadway Length (mi.)	3.5 (approx.)
Existing Roadway Section	NEW LOCATION
Existing ROW Width	n/a
Proposed Roadway Section	84 ft B-B Roadway w/ sidewalks
Proposed ROW Width	120 ft.
Estimated Parcel Count	9
Estimated ROW Area (sq. ft.)	2328480
Estimated ROW Area (Ac.)	53.45454545

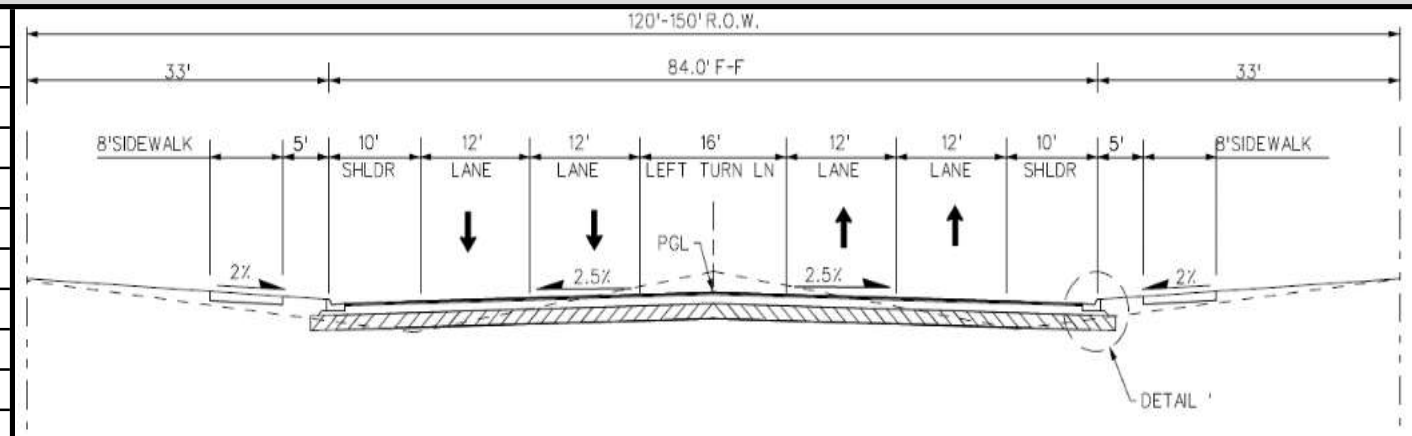

Proposed 84 ft Typical Section

Estimated Project Costs

		Estimated Local %	Estimated Local Cost	Future Funding	Future Funding Breakdown	
					Future Funding (80/20)	Estimated State Participation TxDOT EDC ** 20%-EDC
Estimated Roadway Construction Cost (CAT 7)	\$ 26,250,000.00	6%	\$ 1,522,500.00	\$ 26,250,000.00	\$ 21,000,000.00	\$ 3,727,500.00
Estimated Construction Engineering (CEI) Cost	\$ 2,231,250.00	6%	\$ 129,412.50	\$ 2,231,250.00	\$ 1,785,000.00	\$ 316,837.50
Estimated Project Engineering and Environmental Cost	\$ 2,755,504.00	100%	\$ 2,755,504.00	\$ -	\$ -	\$ -
Estimated ROW Cost	\$ -		\$ -	\$ -	\$ -	\$ -
Estimated ROW Mapping & Acquisition Cost	\$ 31,500.00		\$ 31,500.00	\$ -	\$ -	\$ -
Subtotal(s)	\$ 31,268,254.00		\$ 4,438,916.50	\$ 28,481,250.00	\$ 22,785,000.00	\$ 4,044,337.50
Total Estimated Project Cost	\$ 31,268,254.00					
Total Potential Future Federal and State Involvement	\$ 28,481,250.00					
Total Estimated Local Cost	\$ 4,438,916.50					
Local % of Total Project Cost		14%				
		WA #2	Proj. Engineering \$ 2,755,504.00	ROW Services \$ 31,500.00	Total WA Amt \$ 2,787,004.00	

* TxDOT EDC participation contingent on EDC rate applicable upon execution of TxDOT EDC Agreement (subject to change), estimate based on FY 2023 EDC rate of 71%.