

MARGIE R IBARRA  
COUNTY CLERK  
FILED

2023 MAY -3 AM 10:46

WEBB COUNTY, TEXAS

STATE OF TEXAS §

KNOW ALL MEN BY THESE PRESENTS:

COUNTY OF WEBB §

**Construction Contract**

**Pueblo Nuevo Street Improvement Project Contract CDV21-0485**

BY *all* DEPUTY

This Agreement is made and entered into by and between **WEBB COUNTY, TEXAS**, a Political Subdivision of the State of Texas (hereinafter "Owner") and Anderson Columbia Co., Inc. (hereinafter "Contractor").

**WHEREAS** at the Webb County Commissioner's Court Meeting held on April 26, 2023, the Court, pursuant to Webb County's Invitation to Bid (I.T.B.) 2023-004 entitled "**Pueblo Nuevo Street Improvement Project Contract CDV21-0485**", and Contractor's responsive bid proposal, attached hereto as Exhibit "A", awarded this Project to Anderson Columbia Co., Inc..

For and in consideration of the mutual covenants herein set forth, and other good and valuable consideration, the Parties do hereby agree as follows:

1. **DESCRIPTION OF PROJECT:** The project consists of constructing West Meirs Street approximately one thousand three hundred seventy-five linear feet (1,375 LF) of first-time street utilizing five-inch (5 in.) base and one and one-half inch (1 1/2 in.) HMAC and all associated appurtenances and constructing approximately one thousand two hundred linear feet (1,200 LF) of first-time street utilizing five-inch (5 in.) base and one and one-half inch (1 1/2 in.) HMAC and all associated appurtenances in accordance with the attached Construction Plans / Specifications and general notes prepared by the Webb County Engineer's Office.
2. **PREMISES DEFINED:** The project lies within the Pueblo Nuevo Colonia located on State Highway 359 east of the City of Laredo and is further described in the Construction Plans (Exhibit B) pages 3, 4 and 5.
3. **SCOPE OF WORK:** The Scope of Work is all of the Work, including all appurtenances and all incidentals, all labor and materials, as shown and required by the construction documents, which are hereby incorporated by reference. Contractor agrees that all work shall be performed in a good and workmanlike manner and all materials incorporated into the work shall be new materials.
4. **CONTRACT SUM:** In exchange for Contractor's performance of services under this Agreement, Owner shall pay Contractor the following amount(s): **Four Hundred Four Thousand Four Hundred Ninety Dollars (\$404,490.00)**. Any and all payments/disbursements by Webb County shall be made payable to contractor based on an numbered and itemized payment application for percentage of completion of the various base bid item(s), less retainage, for the project as agreed to and made by Contractor to Owner, which shall be approved by **Luis Perez-Garcia, P.E., Webb County Engineer, and/or Guillermo Cuellar, P.E., Webb County Engineering Dept.**, after inspecting the progress of completed

Rev.101520

work and materials on site at the Premises. Said approvals shall not be unduly withheld or delayed.

5. Owner shall make final payment (including the costs and expenses incurred due to change order(s) completed during this project and completion of the Work and then release the **Five percent (5%) retainage** that OWNER previously retained) to Contractor on the day the Project is completed approved and accepted by OWNER. Said approvals shall not be unreasonably withheld or delayed.
6. *It is hereby expressly acknowledged, consented and agreed to by Contractor that the final payment due for the services rendered pursuant to this Agreement shall not be issued to Contractor until Contractor has submitted a signed and sworn "Final Bills Paid Affidavit" confirming payment to each of its subcontractors, laborers, suppliers, and materialmen in full for all labor and materials furnished to Contractor for or in connection with, renovation of, or repair of improvements on or relating to the subject project/property or any portion thereof, pursuant to and in accordance with Sections 53.085 and 53.259 of the Texas Property Code, and that the intentional, knowing, or reckless making of a false or misleading statement in the Affidavit constitutes a criminal offense under said sections cited herein-above and is a Class A Misdemeanor.*
7. **RETAINAGE:** OWNER shall withhold from each installment payment to CONTRACTOR a retainage of FIVE (5%) percent. The retainage shall be paid to CONTRACTOR upon final completion of the work. Completion of the work shall be considered final upon acceptance and written approval by OWNER or his designated representative of the project.
8. **CHANGE ORDERS** In the event either party requests a change from the agreed Scope of Work or Quote in this Agreement, a written change order making such a request shall be prepared by Contractor in accordance with the proposed change. If the Owner or a Third-Party Inspector ("Inspector") requests a change be executed, Owner or Inspector shall, in a timely manner, inform Contractor (via email) of the request. Contractor shall then prepare a written change order in accordance with said request and submit to Owner for Owner's approval and signature. As soon as Owner signs the change order approving the proposed change, Owner shall submit, via email, the approved/signed order to Contractor. Contractor shall begin performance in accordance with the change order only after Contractor receives the written and approved/signed change order. If Contractor requests a change order, Contractor shall prepare a written change order, submit it to Owner for its approval and signature, and the resultant change will only begin on the approved change after Contractor receives the signed change order. Change orders may increase the payment the Owner must pay to Contractor. **IN NO EVENT SHALL THE TOTAL COST OF CHANGE ORDERS EXCEED TWENTY-FIVE PERCENT (25%) OF THE TOTAL AMOUNT OF THIS AGREEMENT.**
9. **NOTICES/CONTACT PERSONS:** Any notice or communication required or permitted to be given hereunder shall be sufficient if sent via electronic transmission to the contact persons for CONTRACTOR and/or OWNER as follows:



To Contractor at: Anderson Columbia Co., Inc.  
2210 VO Tech Drive  
Weslaco, TX 78596-9024  
Phone: (956) 969-4614  
[Mary.Hernandez@andersoncolumbia.com](mailto:Mary.Hernandez@andersoncolumbia.com)

To Webb Engineer at: WEBB COUNTY, TEXAS  
Luis Perez-Garcia, P.E./Webb County Engineer  
Webb County Engineering Dept.  
(956) 523-4054  
[lperezgarcia@webbcountytx.gov](mailto:lperezgarcia@webbcountytx.gov)

10. **DATE OF COMMENCEMENT:** Contractor shall begin construction within **SEVEN (7) CALENDAR DAYS** of being issued a Notice to Proceed from the County.
11. **SUBSTANTIAL COMPLETION:** Substantial Completion is the stage in the progress of the completion of the work covered by this Agreement where the work on the Premises is sufficiently complete in accordance with the work specified in “Scope of Work” as set forth in Section 3. above, including completion of all post-construction clean-up on and about the Premises, which shall be required to be confirmed in writing as being substantially completed, by the execution and issuance of a Certificate of Substantial Completion that is dated and signed by both the Webb County Project Engineer and Owner, so that the Owner (or Owner’s tenant) can occupy and/or utilize the Premises for its intended use.
12. **DATE FOR FINAL COMPLETION/LIQUIDATED DAMAGES:** The date of final completion of this construction project shall be **SIXTY (60) CALENDAR DAYS** after the date of commencement of construction as set forth in the written and dated notice to proceed issued by Owner to Contractor.
13. The time set forth in the proposal for the completion of the Work is an essential element of the Agreement. For each working day under the conditions described in the preceding Paragraph that any work shall remain uncompleted after the expiration of the working days specified in the Agreement, together with any additional working days allowed, the amount per day given in Section B-1 will be deducted from the money due or to become due the Contractor, not as a penalty but as liquidated damages.
14. Said Contractor further agrees to **CONTINUOUSLY PURSUE AND COMPLETE THE WORK** within **SIXTY (60) CALENDAR DAYS** from the date set forth in the Notice to Proceed (Date of Commencement).
15. **Contractor and Owner do hereby acknowledge that “actual damages are uncertain and would be difficult to ascertain” and therefore both parties do hereby mutually agree that the following stipulated sum of per diem liquidated damages is a reasonable amount. The parties further express and acknowledge that the amount of liquidated damages is meant to be “compensatory” and not “punitive”, and Contractor further agrees to pay, as liquidated damages, the sum of Eight hundred fifty dollars (\$850.00) per day for each consecutive calendar day there-in-after the date of Substantial Completion and after the date of Final**

Completion.

**16. INSURANCE: Contractor and Subcontractor Insurance:** The financial integrity of Contractor is of interest to the Owner, therefore, subject to the right of Contractor to maintain reasonable insurance deductibles in such amounts as are approved by the Owner. Contractor shall obtain and maintain in full force and effect for the entire duration of this agreement, and any extension hereof, at Contractor's sole expense, insurance coverage written on an occurrence basis, by companies authorized and admitted to do business in the State of Texas and rated A- (VII) or better by A.M. Best Company (Best's Key Insurance Company Rating Guide, current edition and/or as amended) and/or otherwise acceptable to Webb County/Webb County Risk Manager, the following types and amounts:

- a. The Contractor shall not commence work under this Agreement until it has obtained all the insurance required and such insurance has been approved by the Owner, nor shall the Contractor allow any subcontractor to commence work on its Subcontract until the insurance required of the Subcontractor has been so obtained and approved. The Contractor shall procure and shall maintain during the life of his Contract, insurance in the amounts required.

**17. PAYMENT AND PERFORMANCE BONDS: \*\*\*PLEASE BE ADVISED THAT THIS PROJECT REQUIRES BOTH A PAYMENT & PERFORMANCE BOND FROM THE CONTRACTOR.\*\*\***

**18. Contractor shall supply the required Performance/Payment bonds to Webb County within Seven (7) days of execution of this Agreement or not later than Two (2) working days prior the date of the scheduled pre-construction meeting which shall be the "DEADLINE" for compliance herewith and which both parties have mutually agreed to as an "Express Condition Precedent" to this contract.**

- a. Bonds must be issued by companies authorized and admitted to do business in the State of Texas and rated A-VII or better by A.M. Best Company (Best's Key Rating Guide, current Edition, and as amended) and/or otherwise acceptable to the Owner.

**19. NOTICE TO PROCEED SHALL NOT BE ISSUED TO THE CONTRACTOR BY WEBB COUNTY WITHOUT THE DELIVERY OF ALL STATUTORILY REQUIRED PERFORMANCE AND/OR PAYMENT BONDS AND PROOF OF ALL REQUIRED INSURANCE POLICIES TO WEBB COUNTY BY CONTRACTOR NOT LATER THAN TWO (2) WORKING DAYS PRIOR THE DATE OF THE SCHEDULED PRE-CONSTRUCTION MEETING "DEADLINE". FAILURE OF CONTRACTOR TO PROVIDE SAID BONDS AND/OR INSURANCE POLICIES BY THE DEADLINE SHALL CONSTITUTE A DEFAULT OF YOUR CONTRACT AND WEBB COUNTY SHALL AT THEIR SOLE OPTION AWARD THE CONTRACT TO THE NEXT LOWEST BIDDER OR RE-ADVERTISE THIS PROJECT FOR NEW BIDS/PROPOSALS.**

**20. RELATIONSHIP OF PARTIES:** Contractor is engaged under this Agreement as an



***“INDEPENDENT CONTRACTOR”*** and not as an agent or employee of Owner. Contractor is not entitled to benefits of any kind to which Owner’s employees are entitled, including but not limited to unemployment compensation, workers’ compensation, health insurance, or retirement benefits. Contractor assumes full responsibility for payment of all federal, state and local taxes or contributions, including but not limited to, unemployment insurance, social security, Medicare, and income taxes with respect to Contractor and Contractor’s employees. This Agreement does not create a partnership or a joint venture between the parties hereto, nor does it authorize either party to serve as the legal representative or agent of the other. Neither party has any right or authority to assume, create, or incur any liability or any obligation of any kind, express or implied, against, or in the name of, or on behalf of the other party.

21. **SUCCESSORS AND ASSIGNS:** This Agreement may not be assigned or subcontracted, in full or in part, by either party without first obtaining written consent of the other party. The parties shall not be relieved of its full responsibility for completion of work because of subletting of any portion of the work. This Agreement shall be binding upon and shall ensue to the benefit of the parties hereto and their respective successors, transferees, and assigns.
22. **INDEMNITY:** CONTRACTOR SHALL DEFEND, INDEMNIFY, AND HOLD WEBB COUNTY, IT’S COMMISSIONERS COURT, DIRECTORS, EMPLOYEES, AND AGENTS HARMLESS FROM ANY AND ALL LOSS, EXPENSE, COST, OR LIABILITY (INCLUDING REASONABLE LEGAL FEES AND EXPENSES), ARISING FROM ANY CLAIM OR CAUSE OF ACTION FOR ANY LOSS OR DAMAGE CAUSED BY OR ARISING FROM THE PERFORMANCE OF CONTRACTOR’S OBLIGATIONS UNDER THIS AGREEMENT, INCLUDING, BUT NOT LIMITED TO, THE CONDUCT OF CONTRACTOR’S EMPLOYEES AND/OR ANY ACTS PERFORMED UNDER THIS CONTRACT AND THAT RESULT FROM ANY NEGLIGENT ACT, ERROR, OR OMISSION OF THE CONTRACTOR OR OF ANY PERSON EMPLOYED BY THE CONTRACTOR. IN CASE OF ANY SUCH CLAIM, CONTRACTOR, UPON NOTICE FROM OWNER, COVENANTS TO DEFEND ANY SUCH ACTION OR PROCEEDING. THE CONTRACTOR SHALL ALSO SAVE AND HOLD HARMLESS THE OWNER FROM AND AGAINST ANY AND ALL EXPENSES, COURT COSTS, INCLUDING, BUT NOT LIMITED TO, ATTORNEY’S FEES THAT MIGHT BE INCURRED IN LITIGATION OR OTHERWISE DEFENDING OR PROSECUTING THE CLAIMS.
23. **COMPLIANCE WITH LAWS:** Contractor agrees that it will, in its performance of its obligations hereunder, fully comply with all applicable laws, regulations and ordinances of all relevant authorities, including, but not limited to, those pertaining to safety, and shall obtain all licenses, registrations, or other approvals required in order to fully perform its obligations hereunder. Contractor represents and warrants that all improvements made to the property shall comply with the Americans with Disabilities Act (ADA) and all other applicable Federal/State Codes, regulations, and laws.
24. **SEVERABILITY:** Should any part of this Agreement be rendered or declared invalid by a court of competent jurisdiction of the State of Texas, such invalidation of such part or portion

of this Agreement shall not invalidate the remaining portions thereof, and they shall remain in full force and effect.

25. **GOVERNING LAW/VENUE:** This agreement shall be governed by and construed and interpreted in accordance with the laws of the State of Texas, without regard to choice of law rules of any jurisdiction. The parties hereby further agree that for any litigation regarding this agreement that venue lies exclusively in the State Courts of Webb County, Texas.
26. **OWNER'S RIGHT TO TERMINATE.** Owner may terminate this this Agreement upon thirty (30) days prior written notice. If Owner terminates this Agreement then Contractor shall only be paid for the work performed or expenses incurred prior to the receipt of notice of termination.
27. **DEFAULT AND TERMINATION:** In the event either party interferes with the general progress of this Project intentionally, or by negligence, or intentional or negligent delay, the non-defaulting party may complete the same or cause the same to be completed and charge all sums of money so expended for the completion of this Agreement against the defaulting party, and the defaulting party shall reimburse the non-defaulting Party for any loss sustained thereby.
28. **ATTORNEY'S FEES:** In the event either party breaches any of the terms of this Agreement whereby the party not in default employs attorneys to protect or enforce its rights hereunder and prevails, then the defaulting party agrees to pay the other party reasonable attorney's fees incurred by such other party.
29. **ENTIRE AGREEMENT:** This Agreement and its Exhibits shall constitute the complete and exclusive written expression of the intentions of the parties hereto and shall supersede all previous communications, representations, agreements, promises or statements, either oral or written, by and between the parties. Any modifications to this Agreement must be in writing and signed by the party sought to be bound.
30. **EXHIBITS:** The following documents are attached hereto and fully incorporated herein by reference and made a part of this agreement as if fully set forth herein:
  1. Contractor's Bid Proposal attached hereto as **Exhibit "A"**.
  2. Construction/Plans/Drawings **Exhibit "B"**.
  3. Webb County's General Conditions, **Exhibit "C"**.
  4. Payment Bond - See sample form: (To be provided by Contractor Prior to Issuance of Notice to Proceed). (See Section 17\*\*), **"Exhibit D"**.
  5. Performance Bond – See sample form: (To be provided by Contractor Prior to Issuance of Notice to Proceed). (See Section 17\*\*), **"Exhibit E"**.
  6. Webb County's Notice to Proceed Letter - See sample form **"Exhibit F"**.

7. Federal Requirements, “Exhibit G”.

- 31. OMISSIONS:** If any punctuation, word, clause, sentence, or provision necessary to give meaning, validity, or effect to any portion of this Agreement shall be omitted here-from, then it is hereby declared that such omission was unintentional and that the omitted element shall be included in order to give meaning, validity, and/or effect to any portion of this Agreement.
- 32. MATERIALMEN/SUPPLIERS:** Contractor within 10 days from the date of the execution of this agreement shall provide an updated and current listing of all Subcontractors and/or Materialmen or Suppliers, and all laborers, used by the Contactor to Webb County and Contractor shall notify the Owner in writing whenever changes occur, and Contractor shall provide the Owner with an updated listing within FIVE (5) working days of upon request for an updated listing. Contractor will immediately notify the Owner in writing of any Subcontractors and/or Materialmen or Suppliers, and all laborers, independent contractors, and/or other such materialmen and/or suppliers services that are discontinued and/or that have been added to their workforce.
- 33. REQUEST FOR PAYMENT SUBMISSION:** All request for payments are to be made payable to Contractor by dated and signed invoice(s). Said invoice and/or request for progress payments shall be submitted in writing to **Luis Perez-Garcia, P.E., Webb County Engineer**, or its designated and authorized representative, on behalf of Owner for review and approval of same. Upon review and approval of the request for payment by **Luis Perez-Garcia, P.E., Webb County Engineer**, on behalf of Owner, the Webb County Engineer shall then forward the approved request for the payment amount [less Five percent (5%) retainage] to the Webb County Business Office to process the progress payment request. Payment will be mailed to Contractor or made available for pick up at the Webb County Business Office.
- 34. COMPLIANCE WITH APPLICABLE LAWS AND ORDINANCES:** Contractor agrees to comply at all times with all federal, state, county, and/or City of Laredo building, development codes, city building permits, rules, regulations, ordinances and laws, and Contractor shall not permit the Premises or any part thereof to be used for (a) any offensive, noisy, or dangerous activity that would pose a health or safety risk; (b) the creation or maintenance of a public nuisance, (c) anything which is against public regulations or rules of any public authority at any time applicable to the Premises; or (d) any purpose or any manner which will obstruct, interfere with, or infringe on the rights of other tenants or adjoining properties.
- 35. LEGAL CONSTRUCTION:** In case any one or more of the provisions contained in the Agreement shall for any reason be held to be invalid, illegal, or unenforceable in any respect, such invalidity, illegality, or unenforceability shall not affect any other provision thereof and this Agreement shall be construed as if such invalid, illegal, or unenforceable provision had never been contained herein.
- 36. AMENDMENT:** No amendment, modification, or alteration of the terms of this Agreement hereof shall be binding unless the same be in writing, dated subsequent to the date hereof, and approved by the Webb County Commissioner’s Court and duly executed by both of the parties



hereto.

**37. TIME OF ESSENCE:** Time is of the essence of this Agreement and each and every covenant, condition, and provision herein contained.

**38. ADDITIONAL PROVISIONS:**

- a. **Inconsistencies.** Where there exists any inconsistency between this Agreement and other provisions of collateral contractual agreements that are made a part hereof by reference or otherwise, the provisions of this Agreement shall control.
- b. **Entire Agreement.** This Agreement incorporates all the agreements, covenants, and understandings between the parties hereto concerning the subject matter hereof, and all such covenants, agreements, and understandings have been merged into this written Agreement. No other prior agreement or understandings, verbal or otherwise, of the parties or their agents shall be valid or enforceable unless signed by both parties and attached hereto and/or embodied herein.
- c. **No rights created.** This Agreement is not intended and does not create any rights or interest in persons not a party hereto.
- d. **Confidentiality.** Any confidential information provided to or developed by Consultant in the performance of this Agreement shall be kept confidential, unless otherwise provided by law, and shall not be made available to any individual or organization without the prior approval of **WEBB COUNTY**.
- e. **Headings.** The headings used herein are for convenience of reference only and shall not constitute a part hereof or affect the construction or interpretation hereof.
- f. **Waiver.** The failure on the part of any party to exercise or to delay in exercising, and no course of dealing with respect to any right hereunder shall operate as a waiver thereof; nor shall any single or partial exercise of any right hereunder preclude any other or further exercise thereof or the exercise of any other right. The remedies provided herein are cumulative and not exclusive of any remedies provided by law or in equity, except as expressly set forth herein.
- g. **Consequential Damages.** Neither party shall be liable to the other for consequential damages, including, without limitation, loss of use or loss of profits, incurred by one another or their subsidiaries or successors, regardless of whether such damages are caused by breach of contract, will-full misconduct, negligent act or omission, or other wrongful act of either of them.
- h. **Counterparts.** This Agreement may be executed in any number of and by the different parties hereto on separate counterparts, each of which when so executed shall be deemed

to be an original, and such counterparts shall together constitute but one and the same document.

- i. **Terminology and Definitions.** All personal pronouns used herein, whether used in the masculine, feminine, or neutral, shall include all other genders; the singular shall include the plural and the plural shall include the singular.
- j. **Rule of Construction.** The parties hereto acknowledge that each party and its legal counsel have reviewed and revised this agreement, and the parties hereby agree that the normal rule of construction to the effect that any ambiguities are to be resolved against the drafting party shall not be employed in the interpretation of this agreement or any amendments or exhibits hereto.

This Agreement becomes effective when signed by the last party whose signing makes the Agreement fully executed.

**IN WITNESS WHEREOF**, the parties aforesaid have duly executed the foregoing instrument, or caused the same to be executed in duplicate originals on the dates set forth below.

**[Remainder of Page Intentionally Left Blank – Signature Page to Follow]**

**WEBB COUNTY**

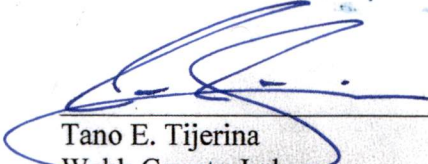
  
\_\_\_\_\_  
Tano E. Tijerina  
Webb County Judge

Date: May 2, 2023

**ATTESTED:**

  
\_\_\_\_\_  
Margie Ramirez-Ibarra  
Webb County Clerk

**APPROVED AS TO FORM:**

  
\_\_\_\_\_  
Nathan R. Bratton  
Webb County Civil Legal Division

\*By law, this office may only advise or approve contracts or legal documents on behalf of its clients. It may not advise or approve a contract or legal document on behalf of other parties. Our review of this document was conducted solely from the legal perspective of our client. Our approval of this document was offered solely for the benefit of our client. Other parties should not rely on this approval, and should seek review and approval of their own respective attorney(s).

**CONTRACTOR**  
ANDERSON COLUMBIA CO., INC.

  
\_\_\_\_\_  
Berry O'Brian  
Vice President

Date: May 2, 2023





**ITB 2023-004 Pueblo Nuevo Street Improvement Addendum 2**

**Project Contract CDV21-0485**

**Issue Date: 3/24/2023**

**Questions Deadline: 4/4/2023 05:00 PM (CT)**

**Response Deadline: 4/11/2023 10:00 AM (CT)**

### **Contact Information**

**Contact: Mr. Juan Guerrero Contract Administrator**

**Address: 1110 Washington St.**

**Suite 101**

**Laredo, TX 78040**

**Phone: (956) 523-4149**

**Email: [jguerrero@webbcountytx.gov](mailto:jguerrero@webbcountytx.gov)**

## Event Information

Number: ITB 2023-004 Pueblo Nuevo Street Improvement Addendum 2  
Title: Project Contract CDV21-0485  
Type: Invitation To Bid  
Issue Date: 3/24/2023  
Question Deadline: 4/4/2023 05:00 PM (CT)  
Response Deadline: 4/11/2023 10:00 AM (CT)  
Notes: **Download All Attachments** Please upload your response documents in the "Response Attachments" tab before completing your submission.

## Bid Activities

### Pre-Bid Meeting / Site Visit

4/4/2023 10:00:00 AM (CT)

A Pre-Bid meeting will be held on April 4, 2023 at 10 am at the Webb County Purchasing Department located on 1110 Washington St. Ste. 101, Laredo, TX 78040.

## Bid Attachments

<b>ITB 2023-004 Pueblo Nuevo Street Improvement Project Contract CDV21-0485.pdf</b> ITB 2023-004	<a href="#">Download</a>
<b>Pueblo Nuevo Bid Price Sheet.xlsx</b> Bid Price Sheet	<a href="#">Download</a>
<b>Pueblo Nuevo Construction Plans 2023.pdf</b> Construction Plans	<a href="#">Download</a>
<b>Figure A1.pdf</b> A1	<a href="#">Download</a>
<b>Figure A2.pdf</b> A2	<a href="#">Download</a>
<b>Attachment A Minumum Wage Requirements.pdf</b> Attachment A	<a href="#">Download</a>
<b>Additional Forms.pdf</b> Additional Forms	<a href="#">Download</a>
<b>General Affidavit Purchasing Ethics.pdf</b> Affidavit	<a href="#">Download</a>
<b>Addendum 1.pdf</b> Addendum 1	<a href="#">Download</a>
<b>Addendum 2.pdf</b> Addendum 2	<a href="#">Download</a>





**ADDENDUM NUMBER 1 TO THE BID DOCUMENTS**

Addendum Date: March 27, 2023

**BID DOCUMENT NUMBER ITB 2023-004**

**“Pueblo Nuevo Street Improvement Project Contract CDV21-0485”**

A. This Addendum shall be considered part of the bid documents for the above-mentioned project as though it had been issued at the same time and shall be incorporated integrally therewith. Where provisions of the following supplementary data differ from those of the original bid documents, this Addendum shall govern and take precedence. **BIDDERS MUST SIGN THE ADDENDUM AND SUBMIT IT WITH THEIR BIDS/PROPOSALS.**

B. Bidders are hereby notified that they shall make any necessary adjustments in their estimates as a result of this Addendum. It will be construed that each bidder's proposal is submitted with full knowledge of all modifications and supplemental data specified herein.

Except as described below, the original bid document remains unchanged. The bid documents are modified and/or clarified, as follows:

- **The deadline to submit bids has been modified from Monday April 17 to Tuesday April 11, 2023 at 10 am. See updated ITB Schedule of Events below.**
- **The Pre-Bid meeting date has been modified from Thursday April 6 to Tuesday April 4, 2023 at 10 a.m. See updated ITB Schedule of Events below.**
- **The Question deadline date has been modified from Thursday April 6 to Tuesday April 4, 2023 at 5 p.m. See updated ITB Schedule of Events below.**

Activity	Time	Date	Responsible Party
Public Notice/Newspaper	n/a	Mar. 28 <sup>th</sup> , Apr. 4 <sup>th</sup>	County Purchasing Office
Posted ITB on Website	n/a	Mar. 24 <sup>th</sup> - Until awarded	County Purchasing Office
Pre-Bid Meeting	10 am	Apr. 4 <sup>th</sup>	County Purchasing Office
Questions Due to County	No later than 5pm	Apr. 4 <sup>th</sup>	Respondent
Posting of Answers	No later than 5pm	Apr. 5 <sup>th</sup>	County Purchasing Office
Sealed Bids Due	10 am (CT)	Apr. 11 <sup>th</sup>	Respondent
Evaluation of Proposals	TBD	Apr. 11 <sup>th</sup> – Apr. 14 <sup>th</sup>	Scoring Committee
Award of Contract	TBD	TBD	Governing Body
Finalization of Contract	TBD	TBD	Governing Body

*Footnote: County reserves the right to adjust time and dates on above projected schedule if it is in the best interest for Webb County. Addendum will be issued to inform the Public and all interested parties.*

**A Pre-Bid meeting will be held on April 4, 2023 at 10 am at the Webb County Purchasing Department located on 1110 Washington St. Ste. 101, Laredo, TX 78040.**

**BIDDER MUST ACKNOWLEDGE THIS ADDENDUM BY SIGNING BELOW AND ATTACHING THE SIGNED ADDENDUM TO THE BID FORM(s):**

Company Name ANDERSON COLUMBIA CO., INC.

Contact Person BERRY O'BRYAN

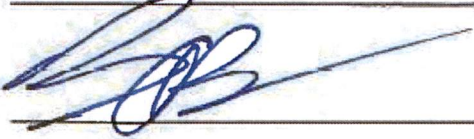
Signature 

Date APRIL 11, 2023

**THIS CONCLUDES ADDENDUM NO. 1 IN ITS ENTIRETY.**

This Addendum is being transmitted electronically via our E-Bid site @ <https://webbcountyebid.ionwave.net/Login.aspx> . If you have any questions, please direct them to; Juan Guerrero Jr. (956) 523-4149 or email at [juguerrero@webbcountytexas.gov](mailto:juguerrero@webbcountytexas.gov) .

County of Webb

**ADDENDUM NUMBER 2 TO THE BID DOCUMENTS**

Addendum Date: March 27, 2023

**BID DOCUMENT NUMBER ITB 2023-004**

**“Pueblo Nuevo Street Improvement Project Contract CDV21-0485”**

---

A. This Addendum shall be considered part of the bid documents for the above-mentioned project as though it had been issued at the same time and shall be incorporated integrally therewith. Where provisions of the following supplementary data differ from those of the original bid documents, this Addendum shall govern and take precedence. **BIDDERS MUST SIGN THE ADDENDUM AND SUBMIT IT WITH THEIR BIDS/PROPOSALS.**

B. Bidders are hereby notified that they shall make any necessary adjustments in their estimates as a result of this Addendum. It will be construed that each bidder's proposal is submitted with full knowledge of all modifications and supplemental data specified herein.

Except as described below, the original bid document remains unchanged. The bid documents are modified and/or clarified, as follows:

- **The Insurance Requirements for this project are as follows:**

**Section 1.34 Insurance Requirements**

**Commercial General Liability:** \$1,000,000 per occurrence combined single limit for bodily injury and property damage, \$2,000,000 general aggregate, and a separate products/completed operations aggregate of \$2,000,000. Coverage for Personal Injury and Advertising Injury should also be included in the amount of \$1,000,000 per occurrence. The County will be added as a primary and non-contributory additional insured. The Contractor's carrier will agree to Waive Their Right to Subrogate against the County and 60 Days' notice of cancellation to the County directly from the Carrier.

**Commercial automobile:** \$1M Combined Single Limit BUI & PD per Accident (Occurrence) - The County will be added as a primary and non-contributory Additional Insured. The Contractor's carrier will agree the Waive Their Rights to Subrogate against the County and 60 Days' Notice of Cancellation to the County directly from the Carrier.

**Workers Compensation:** Coverage A: Statutory Texas Medical, Accidental Death or Dismemberment and Lost time as mandated by the Texas Workers' Compensation Statute; Coverage B: Employers Liability - \$1M Per Employee Per Accident/ \$1M Per Employee - Disease/ \$1M Policy Aggregate - The Contractor's carrier will agree the Waive Their Rights to Subrogate Against the County and 60 Days' Notice of Cancellation to the County directly from the Carrier.

Webb County as primary, non-contributory additional insured on GL and auto  
Waiver of subrogation in favor of Webb County for all required insurance policies  
Webb County as Obligee on the payment/performance bond.

Addendum No. 2 - Page 1 of 2

Exhibit A

Construction Contract Pueblo Nuevo Street Improvement Project Contract CDV21-0485 (I.T.B. 2023-004)

Webb County, Owner – Anderson Columbia Co., Inc., Contractor

Page 6 of 35

**BIDDER MUST ACKNOWLEDGE THIS ADDENDUM BY SIGNING BELOW AND ATTACHING THE SIGNED ADDENDUM TO THE BID FORM(s):**

Company Name ANDERSON COLUMBIA CO., INC.

Contact Person BERRY O'BRYAN

Signature 

Date APRIL 11, 2023

**THIS CONCLUDES ADDENDUM NO. 2 IN ITS ENTIRETY.**

This Addendum is being transmitted electronically via our E-Bid site @ <https://webbcountyebid.ionwave.net/Login.aspx>. If you have any questions, please direct them to; Juan Guerrero Jr. (956) 523-4149 or email at [juguerrero@webbcountytx.gov](mailto:juguerrero@webbcountytx.gov).

**THIS FORM MUST BE INCLUDED WITH ITB PACKAGE; PLEASE CHECK OFF EACH ITEM INCLUDED WITH ITB PACKAGE AND SIGN BELOW TO COMPLETE SUBMITTAL / COMPLETION OF EACH REQUIRED ITEM.**

**Invitation to Bid (ITB)  
ITB 2023-004**

**“Pueblo Nuevo Street Improvement Project Contract CDV21-0485”**

- Pueblo Nuevo Bid Price Sheet
  
- Reference Form
  
- Conflict of Interest Form (CIQ)
  
- Certification regarding Debarment (Form H2048)
  
- Certification regarding Federal lobbying (Form 2049)
  
- Code of Ethics Affidavit
  
- House Bill 89 Form
  
- Senate Bill 252 Form
  
- SAMs Registration completed by Offeror (See Section 1.13)
  
- Proof of No Delinquent Tax Owed to Webb County

  
**Signature of Person Completing this Package**

4/11/23  
**Date**



WEST MEIRS					
ITEM NO.	ITEM DESCRIPTION	UNITS	QUANTITY	UNIT PRICE	EXTENDED PRICE
1	EXCAVATION (ROADWAY)	CY	785	\$ 42.00	\$ 32,970.00
2	FL BS (CMP IN PLC) (TY A GR 4) (FINAL POS)	CY	785	\$ 125.00	\$ 98,125.00
3	D-GR HMA (SQ) TY-D SAC-B PG70-22	TON	420	\$ 180.00	\$ 75,600.00
4	PRIME COAT MC-30	GAL	900	\$ 08.00	\$ 7,200.00
5	MOBILIZATION	LS	1	\$45,000.00	\$ 45,000.00
6	BARRICADES, SIGNS AND TRAFFIC HANDLING	MO	1	\$ 5,000.00	\$ 5,000.00
7	ALUMINUM SIGNS (TY A)	EA	1	\$ 1,800.00	\$ 1,800.00
8	REFL PAV MRK TY I (W)24" (SLD)(090MIL)	LF	12	\$ 50.00	\$ 600.00
9	4'X8' PROJECT SIGN	EA	1	\$ 2,000.00	\$ 2,000.00
<b>SUB-TOTAL BID AMOUNT FOR WEST MEIRS</b>					<b>\$ 268,295.00</b>

WEST PAREDES					
ITEM NO.	ITEM DESCRIPTION	UNITS	QUANTITY	UNIT PRICE	EXTENDED PRICE
1	EXCAVATION (ROADWAY)	CY	685	\$ 42.00	\$ 28,770.00
2	FL BS (CMP IN PLC) (TY A GR 4) (FINAL POS)	CY	685	\$ 125.00	\$ 85,625.00
3	D-GR HMA (SQ) TY-D SAC-B PG70-22	TON	380	\$ 180.00	\$ 68,400.00
4	PRIME COAT MC-30	GAL	750	\$ 08.00	\$ 6,000.00
5	BARRICADES, SIGNS AND TRAFFIC HANDLING	LS	1	\$ 5,000.00	\$ 5,000.00
6	ALUMINUM SIGNS (TY A)	EA	1	\$ 1,800.00	\$ 1,800.00
7	REFL PAV MRK TY I (W)24" (SLD)(090MIL)	LF	12	\$ 50.00	\$ 600.00
<b>SUB-TOTAL BID AMOUNT FOR WEST MEIRS</b>					<b>\$ 196,195.00</b>

**Total Base Bid Amount \$ 464,490.00**

**Total Base Bid Amount in Words**

**ANDERSON COLUMBIA CO., INC.**

Contractor Name



Signature of Authorized Bidder

**VICE PRESIDENT**

Title

**P.O BOX 565**

Address

**WESLACO, TEXAS**

City, State

**78599**

Zip Code



### References Form

Please list at minimum five (5) local governmental entities where similar scope of work was provided.

**THIS FORM MUST BE RETURNED WITH YOUR OFFER.**

**REFERENCE ONE**

Government/Company Name: Texas Department of Transportation

Address: 1817 Bob Bullock Loop, Laredo, TX 78043

Contact Person and Title: Jose Vargas, P.E., Area Engineer

Phone: (956) 712-7400 Fax: (956) 712-7401

Email Address: Jose.Vargas@txdot.gov Contract Period: September 2019

Description of Construction Services Provided: \_\_\_\_\_

Construction of of rehabilitation of existing highway, intersection  
improvements and passing lanes at US83.

**REFERENCE TWO**

Government/Company Name: Texas Department of Transportation

Address: 1817 Bob Bullock Loop, Laredo, TX 78043

Contact Person and Title: Jose Vargas, P.E., Area Engineer

Phone: (956) 712-7400 Fax: (956) 712-7401

Email Address: Jose.Vargas@txdot.gov Contract Period: March 2022

Description of Construction Services Provided: \_\_\_\_\_

Construction of overlay consisting of planing, overlaying, rail  
upgrades & pavement markings on IH35.

**REFERENCE THREE**

Government/Company Name: Webb County

Address: 1110 Washington Street, Suite 101

Contact Person and Title: Guillermo Cuellar, Webb County Engineer

Phone: (956) 523-4185 Fax: (956) 523-5158

Email Address: gbcuellar@webbcountytexas.gov Contract Period: February 2022

Description of Construction Services Provided: \_\_\_\_\_

Pueblo Nuevo Road overlay and striping from SH359 to Ozuna Ave.

\_\_\_\_\_

\_\_\_\_\_

**REFERENCE FOUR**

Government/Company Name: Webb County

Address: 1110 Washington Street, Suite 101

Contact Person and Title: Guillermo Cuellar, Webb County Engineer

Phone: (956) 523-4185 Fax: (956) 523-5158

Email Address: gbcuellar@webbcountytexas.gov Contract Period: March 2022

Description of Construction Services Provided: \_\_\_\_\_

Penitas Road overlay and striping from FM 3338 to end of pavement.

\_\_\_\_\_

\_\_\_\_\_

REFERENCE Five

Government/Company Name: Webb County

Address: 1110 Washington Street, Suite 101

Contact Person and Title: Guillermo Cuellar, Webb County Engineer

Phone: (956) 523-4185 Fax: (956) 523-5158

Email Address: gbcuellar@webbcountytexas.gov Contract Period: March 2022

Description of Construction Services Provided: \_\_\_\_\_

Las Lomas Road overlay and striping from US 59 to 7152Q.

\_\_\_\_\_  
\_\_\_\_\_

• **\*\*Additional pages are permitted if more space is required\*\***

Space intentionally left Blank

**CONFLICT OF INTEREST QUESTIONNAIRE**  
For vendor doing business with local governmental entity

**FORM CIQ**

This questionnaire reflects changes made to the law by H.B. 23, 84th Leg., Regular Session.  
This questionnaire is being filed in accordance with Chapter 176, Local Government Code, by a vendor who has a business relationship as defined by Section 176.001(1-a) with a local governmental entity and the vendor meets requirements under Section 176.006(a).  
By law this questionnaire must be filed with the records administrator of the local governmental entity not later than the 7th business day after the date the vendor becomes aware of facts that require the statement to be filed. See Section 176.006(a-1), Local Government Code.  
A vendor commits an offense if the vendor knowingly violates Section 176.006, Local Government Code. An offense under this section is a misdemeanor.

**OFFICE USE ONLY**

Date Received

1 Name of vendor who has a business relationship with local governmental entity.  
ANDERSON COLUMBIA CO., INC.

2  Check this box if you are filing an update to a previously filed questionnaire. (The law requires that you file an updated completed questionnaire with the appropriate filing authority not later than the 7th business day after the date on which you became aware that the originally filed questionnaire was incomplete or inaccurate.) N/A

3 Name of local government officer about whom the information is being disclosed.  
N/A  
Name of Officer

4 Describe each employment or other business relationship with the local government officer, or a family member of the officer, as described by Section 176.003(a)(2)(A). Also describe any family relationship with the local government officer. Complete subparts A and B for each employment or business relationship described. Attach additional pages to this Form CIQ as necessary.

A. Is the local government officer or a family member of the officer receiving or likely to receive taxable income, other than investment income, from the vendor?

Yes  No N/A

B. Is the vendor receiving or likely to receive taxable income, other than investment income, from or at the direction of the local government officer or a family member of the officer AND the taxable income is not received from the local governmental entity?

Yes  No N/A

5 Describe each employment or business relationship that the vendor named in Section 1 maintains with a corporation or other business entity with respect to which the local government officer serves as an officer or director, or holds an ownership interest of one percent or more.

N/A

6  Check this box if the vendor has given the local government officer or a family member of the officer one or more gifts as described in Section 176.003(a)(2)(B), excluding gifts described in Section 176.003(a-1). N/A

7  APRIL 11, 2023  
Signature of Vendor doing business with the governmental entity Date

**CONFLICT OF INTEREST QUESTIONNAIRE**  
**For vendor doing business with local governmental entity**

A complete copy of Chapter 176 of the Local Government Code may be found at <http://www.statutes.legis.state.tx.us/Docs/LG/htm/LG.176.htm>. For easy reference, below are some of the sections cited on this form.

**Local Government Code § 176.001(1-a):** "Business relationship" means a connection between two or more parties based on commercial activity of one of the parties. The term does not include a connection based on:

- (A) a transaction that is subject to rate or fee regulation by a federal, state, or local governmental entity or an agency of a federal, state, or local governmental entity;
- (B) a transaction conducted at a price and subject to terms available to the public; or
- (C) a purchase or lease of goods or services from a person that is chartered by a state or federal agency and that is subject to regular examination by, and reporting to, that agency.

**Local Government Code § 176.003(a)(2)(A) and (B):**

(a) A local government officer shall file a conflicts disclosure statement with respect to a vendor if:

(2) the vendor:

(A) has an employment or other business relationship with the local government officer or a family member of the officer that results in the officer or family member receiving taxable income, other than investment income, that exceeds \$2,500 during the 12-month period preceding the date that the officer becomes aware that

(i) a contract between the local governmental entity and vendor has been executed;

or

(ii) the local governmental entity is considering entering into a contract with the vendor;

(B) has given to the local government officer or a family member of the officer one or more gifts that have an aggregate value of more than \$100 in the 12-month period preceding the date the officer becomes aware that:

(i) a contract between the local governmental entity and vendor has been executed; or

(ii) the local governmental entity is considering entering into a contract with the vendor.

**Local Government Code § 176.006(a) and (a-1)**

(a) A vendor shall file a completed conflict of interest questionnaire if the vendor has a business relationship with a local governmental entity and:

(1) has an employment or other business relationship with a local government officer of that local governmental entity, or a family member of the officer, described by Section 176.003(a)(2)(A);

(2) has given a local government officer of that local governmental entity, or a family member of the officer, one or more gifts with the aggregate value specified by Section 176.003(a)(2)(B), excluding any gift described by Section 176.003(a-1); or

(3) has a family relationship with a local government officer of that local governmental entity.

(a-1) The completed conflict of interest questionnaire must be filed with the appropriate records administrator not later than the seventh business day after the later of:

(1) the date that the vendor:

(A) begins discussions or negotiations to enter into a contract with the local governmental entity; or

(B) submits to the local governmental entity an application, response to a request for proposals or bids, correspondence, or another writing related to a potential contract with the local governmental entity; or

(2) the date the vendor becomes aware:

(A) of an employment or other business relationship with a local government officer, or a family member of the officer, described by Subsection (a);

(B) that the vendor has given one or more gifts described by Subsection (a); or

(C) of a family relationship with a local government officer.

**CERTIFICATION  
REGARDING DEBARMENT, SUSPENSION, INELIGIBILITY AND VOLUNTARY  
EXCLUSION FOR COVERED CONTRACTS**

**PART A.**

Federal Executive Orders 12549 and 12689 require the Texas Department of Agriculture (TDA) to screen each covered potential contractor to determine whether each has a right to obtain a contract in accordance with federal regulations on debarment, suspension, ineligibility, and voluntary exclusion. Each covered contractor must also screen each of its covered subcontractors.

In this certification "contractor" refers to both contractor and subcontractor; "contract" refers to both contract and subcontract.

By signing and submitting this certification the potential contractor accepts the following terms:

1. The certification herein below is a material representation of fact upon which reliance was placed when this contract was entered into. If it is later determined that the potential contractor knowingly rendered an erroneous certification, in addition to other remedies available to the federal government, the Department of Health and Human Services, United States Department of Agriculture or other federal department or agency, or the TDA may pursue available remedies, including suspension and/or debarment.
2. The potential contractor will provide immediate written notice to the person to which this certification is submitted if at any time the potential contractor learns that the certification was erroneous when submitted or has become erroneous by reason of changed circumstances.
3. The words "covered contract", "debarred", "suspended", "ineligible", "participant", "person", "principal", "proposal", and "voluntarily excluded", as used in this certification have meanings based upon materials in the Definitions and Coverage sections of federal rules implementing Executive Order 12549. Usage is as defined in the attachment.
4. The potential contractor agrees by submitting this certification that, should the proposed covered contract be entered into, it will not knowingly enter into any subcontract with a person who is debarred, suspended, declared ineligible, or voluntarily excluded from participation in this covered transaction, unless authorized by the Department of Health and Human Services, United States Department of Agriculture or other federal department or agency, and/or the TDA, as applicable.

Do you have or do you anticipate having subcontractors under this proposed contract?

Yes

No



5. The potential contractor further agrees by submitting this certification that it will include this certification titled "Certification Regarding Debarment, Suspension, Ineligibility, and Voluntary Exclusion for Covered Contracts" without modification, in all covered subcontracts and in solicitations for all covered subcontracts.
6. A contractor may rely upon a certification of a potential subcontractor that it is not debarred, suspended, ineligible, or voluntarily excluded from the covered contract, unless it knows that the certification is erroneous. A contractor must, at a minimum, obtain certifications from its covered subcontractors upon each subcontract's initiation and upon each renewal.
7. Nothing contained in all the foregoing will be construed to require establishment of a system of records in order to render in good faith the certification required by this certification document. The knowledge and information of a contractor is not required to exceed that which is normally possessed by a prudent person in the ordinary course of business dealings.
8. Except for contracts authorized under paragraph 4 of these terms, if a contractor in a covered contract knowingly enters into a covered subcontract with a person who is suspended, debarred, ineligible, or voluntarily excluded from participation in this transaction, in addition to other remedies available to the federal government, Department of Health and Human Services, United States Department of Agriculture, or other federal department or agency, as applicable, and/or the TDA may pursue available remedies, including suspension and/or debarment.

**PART B. CERTIFICATION REGARDING DEBARMENT, SUSPENSION, INELIGIBILITY AND VOLUNTARY EXCLUSION FOR COVERED CONTRACTS**

Indicate in the appropriate box which statement applies to the covered potential contractor.

- The potential contractor certifies, by submission of this certification, that neither it nor its principals is presently debarred, suspended, proposed for debarment, declared ineligible, or voluntarily excluded from participation in this contract by any federal department or agency or by the State of Texas.
- The potential contractor is unable to certify to one or more of the terms in this certification. In this instance, the potential contractor must attach an explanation for each of the above terms to which he is unable to make certification. Attach the explanation(s) to this certification.

Name of Contractor	Vendor ID No. or Social Security No.	Program No.
Anderson Columbia Co., Inc.	59-2871935	

  
Signature of Authorized Representative

April 11, 2023  
Date

Berry O'Bryan, Vice President  
Printed/Typed Name and Title of  
Authorized Representative

**CERTIFICATION REGARDING FEDERAL LOBBYING**  
**(Certification for Contracts, Grants, Loans, and Cooperative Agreements)**

**PART A. PREAMBLE**

Federal legislation. Section 319 of Public Law 101-121 generally prohibits entities from using federally appropriated funds to lobby the executive or legislative branches of the federal government. Section 319 specifically requires disclosure of certain lobbying activities. A federal government-wide rule, "New Restrictions on Lobbying", published in the Federal Register, February 26, 1990, requires certification and disclosure in specific instances.

**PART B. CERTIFICATION**

This certification applies only to the instant federal action for which the certification is being obtained and is a material representation of fact upon which reliance was placed when this transaction was made or entered into. Submission of this certification is a prerequisite for making or entering into this transaction imposed by section 1352, title 31, U.S. Code. Any person who fails to file the required certification shall be subject to a civil penalty of not less than \$100,000 for each such failure.

The undersigned certifies, to the best of his or her knowledge and belief, that:

1. No federally appropriated funds have been paid or will be paid, by or on behalf of the undersigned, to any person for influencing or attempting to influence an officer or employee of any agency, a member of Congress, an officer or employee of Congress, or an employee of a member of Congress in connection with the awarding of any federal contract, the making of any federal grant, the making of any federal loan, the entering into of any cooperative agreement, or the extension, continuation, renewal, amendment, or modification of any federal contract, grant, loan, or cooperative agreement.
2. If any funds other than federally appropriated funds have been paid or will be paid to any person for influencing or attempting to influence an officer or employee of any agency, a member of Congress, an officer or employee of Congress, or an employee of a member of Congress in connection with these federally funded contract, subcontract, subgrant, or cooperative agreement, the undersigned shall complete and submit Standard Form-LLL, "Disclosure Form to Report Lobbying", in accordance with its instructions. (If needed, contact the Texas Department of Agriculture to obtain a copy of Standard Form-LLL.)

3. The undersigned shall require that the language of this certification be included in the award documents for all covered subawards at all tiers (including subcontracts, subgrants, and contracts under grants, loans, and cooperative agreements) and that all covered subrecipients will certify and disclose accordingly.

Do you have or do you anticipate having covered subawards under this transaction?

Yes

No

Name of Contractor/Potential Contractor	Vendor ID No. or Social Security No.	Program No.
Anderson Columbia Co., Inc.	59-2871935	

Name of Authorized Representative	Title
Berry O'Bryan	Vice President

  
\_\_\_\_\_  
Signature – Authorized Representative

April 11, 2023  
\_\_\_\_\_  
Date



**WEBB COUNTY PURCHASING DEPT.  
QUALIFIED PARTICIPATING VENDOR CODE OF ETHICS  
AFFIDAVIT FORM**

STATE OF TEXAS \*

KNOW ALL MEN BY THESE PRESENTS:

COUNTY OF WEBB \*

BEFORE ME the undersigned Notary Public, appeared Berry O'Bryan, the herein-named "Affiant", who is a resident of Hidalgo County, State of Texas, and upon his/her respective oath, either individually and/or behalf of their respective company/entity, do hereby state that I have personal knowledge of the following facts, statements, matters, and/or other matters set forth herein are true and correct to the best of my knowledge.

*I personally, and/or in my respective authority/capacity on behalf of my company/entity do hereby confirm that I have reviewed and agree to fully comply with all the terms, duties, ethical policy obligations and/or conditions as required to be a qualified participating vendor with Webb County, Texas as set forth in the Webb County Purchasing Code of Ethics Policy posted at the following address: <http://www.webbcountytexas.gov/PurchasingAgent/PurchasingEthicsPolicy.pdf>*

*I personally, and/or in my respective authority/capacity on behalf of my company/entity do hereby further acknowledge, agree and understand that as a participating vendor with Webb County, Texas on any active solicitation/proposal/qualification that I and/or my company/entity failure to comply with the Code of Ethics policy may result in my and/or my company/entity disqualification, debarment or make void my contract awarded to me, my company/entity by Webb County. I agree to communicate with the Purchasing Agent or his designees should I have questions or concerns regarding this policy to ensure full compliance by contacting the Webb County Purchasing Dept. via telephone at (956) 523-4125 or e-mail to the Webb County Purchasing Agent to [joel@webbcountytexas.gov](mailto:joel@webbcountytexas.gov).*

Executed and dated this 11th day of April, 2023.

  
Signature of Affiant

Berry O'Bryan, Anderson Columbia Co., Inc.  
Printed Name of Affiant/Company/Entity

SWORN to and subscribed before me, this 11th day April, 2023

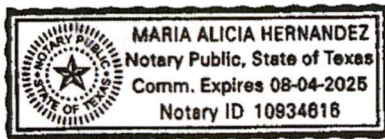

  
NOTARY PUBLIC, STATE OF TEXAS

**Offeror: Complete & Return this Form with Response Submission.  
Senate Bill 252 Certification**

SB 252 CHAPTER 2252 CERTIFICATION I, Berry O'Bryan, the undersigned representative of Anderson Columbia Co., Inc. (Company or business name) being an adult over the age of eighteen (18) years of age, pursuant to Texas Government Code, Chapter 2252, Section 2252.152 and Section 2252.153, certify that the company named above is not listed on the website of the Comptroller of the State of Texas concerning the listing of companies that are identified under Section 806.051, Section 807.051 or Section 2253.153. I further certify that should the above-named company enter into a contract that is on said listing of companies on the website of the Comptroller of the State of Texas which do business with Iran, Sudan or any Foreign Terrorist Organization, I will immediately notify Mr. Jose Angel Lopez III, Webb County Purchasing Agent at (956) 523-4125 or via email at [joel@webbcountytexas.gov](mailto:joel@webbcountytexas.gov)

Berry O'Bryan Name of Company Representative (Print)

 Signature of Company Representative

April 11, 2023 Date



**Offeror: Complete & Return this Form with Response Submission.**

**House Bill 89 Verification**

I, Berry O'Bryan, the undersigned representative of (company or business name) Anderson Columbia Co., Inc. (heretofore referred to as company) being an adult over the age of eighteen (18) years of age, after being duly sworn by the undersigned notary, do hereby depose and verify under oath that the company named above, under the provisions of Subtitle F, Title 10, Government Code Chapter 2270:

1. Does not boycott Israel currently; and
2. Will not boycott Israel during the term of the contract.

Pursuant to Section 2270.001, Texas Government Code:

1. "Boycott Israel" means refusing to deal with, terminating business activities with, or otherwise taking any action that is intended to penalize, inflict economic harm on, or limit commercial relations specifically with Israel, or with a person or entity doing business in Israel or in an Israeli-controlled territory, but does not include an action made ordinary business purposes; and
2. "Company" means a for-profit sole proprietorship, organization, association, corporation, partnership, joint venture, limited partnership, limited liability partnership, or an limited liability company, including a wholly owned subsidiary, majority-owned subsidiary, parent company or affiliate of those entities or business association that exist to make a profit.

  
\_\_\_\_\_  
Signature of Company Representative

April 11, 2023  
\_\_\_\_\_  
Date

On this 11th day of April, 2023, personally appeared  
Berry O'Bryan, the above named person, who after by me  
being duly sworn, did swear and confirm that the above is true and correct.

Notary Seal

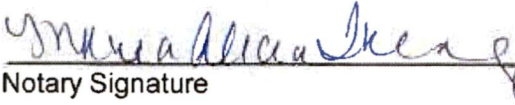
  
\_\_\_\_\_  
Notary Signature

April 11, 2023  
\_\_\_\_\_  
Date

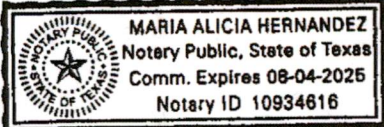





# ANDERSON COLUMBIA CO., INC.

Unique Entity ID HNGFAMR1SW75	CAGE / NCAGE 1RDX9	Purpose of Registration All Awards
Registration Status Active Registration	Expiration Date Dec 2, 2023	
Physical Address 2316 Highway 71 Marianna, Florida 32448-2534 United States	Mailing Address PO Box 1829 Lake City, Florida 32056-1829 United States	

## Business Information

Doing Business as (blank)	Division Name (blank)	Division Number (blank)
Congressional District Florida 02	State / Country of Incorporation Florida / United States	URL <a href="http://www.andersoncolumbia.com">http://www.andersoncolumbia.com</a>

## Registration Dates

Activation Date Dec 6, 2022	Submission Date Dec 2, 2022	Initial Registration Date Sep 4, 2001
--------------------------------	--------------------------------	--

## Entity Dates

Entity Start Date Mar 7, 1988	Fiscal Year End Close Date Dec 31
----------------------------------	--------------------------------------

## Immediate Owner

CAGE (blank)	Legal Business Name (blank)
-----------------	--------------------------------

## Highest Level Owner

CAGE (blank)	Legal Business Name (blank)
-----------------	--------------------------------

## Executive Compensation

In your business or organization's preceding completed fiscal year, did your business or organization (the legal entity to which this specific SAM record, represented by a Unique Entity ID, belongs) receive both of the following: 1. 80 percent or more of your annual gross revenues in U.S. federal contracts, subcontracts, loans, grants, subgrants, and/or cooperative agreements and 2. \$25,000,000 or more in annual gross revenues from U.S. federal contracts, subcontracts, loans, grants, subgrants, and/or cooperative agreements?

No

Does the public have access to information about the compensation of the senior executives in your business or organization (the legal entity to which this specific SAM record, represented by a Unique Entity ID, belongs) through periodic reports filed under section 13(a) or 15(d) of the Securities Exchange Act of 1934 (15 U.S.C. 78m(a), 78o(d)) or section 6104 of the Internal Revenue Code of 1986?

Not Selected

## Proceedings Questions

Is your business or organization, as represented by the Unique Entity ID on this entity registration, responding to a Federal procurement opportunity that contains the provision at FAR 52.209-7, subject to the clause in FAR 52.209-9 in a current Federal contract, or applying for a Federal grant opportunity which contains the award term and condition described in 2 C.F.R. 200 Appendix XII?

No

Does your business or organization, as represented by the Unique Entity ID on this specific SAM record, have current active Federal contracts and/or grants with total value (including any exercised/unexercised options) greater than \$10,000,000?

Not Selected

Within the last five years, had the business or organization (represented by the Unique Entity ID on this specific SAM record) and/or any of its principals, in connection with the award to or performance by the business or organization of a Federal contract or grant, been the subject of a Federal or State (1) criminal proceeding resulting in a conviction or other acknowledgment of fault; (2) civil proceeding resulting in a finding of fault with a monetary fine, penalty, reimbursement, restitution, and/or damages greater than \$5,000, or other acknowledgment of fault; and/or (3) administrative proceeding resulting in a finding of fault with either a monetary fine or penalty greater than \$5,000 or reimbursement, restitution, or damages greater than \$100,000, or other acknowledgment of fault?

Not Selected

## Exclusion Summary

Active Exclusions Records?

No

**SAM Search Authority**

I authorize my entity's non-sensitive information to be displayed in SAM public search results:

Yes

**Entity Types**

**Business Types**

Entity Structure Corporate Entity (Not Tax Exempt)	Entity Type Business or Organization	Organization Factors (blank)
Profit Structure For Profit Organization		

**Socio-Economic Types**

Check the registrant's Reps & Certs, if present, under FAR 52.212-3 or FAR 52.219-1 to determine if the entity is an SBA-certified HUBZone small business concern. Additional small business information may be found in the SBA's Dynamic Small Business Search if the entity completed the SBA supplemental pages during registration.

**Financial Information**

Accepts Credit Card Payments Yes	Debt Subject To Offset Yes	
EFT Indicator 0000	CAGE Code 1RDK9	
<b>Electronic Funds Transfer</b>		
Account Type Checking	Routing Number ****0021	Lock Box Number (blank)
Financial Institution WELLS FARGO BANK	Account Number ****40039546	
<b>Automated Clearing House</b>		
Phone (U.S.) 9044893013	Email (blank)	Phone (non-U.S.) (blank)
Fax (blank)		
<b>Remittance Address</b>		
BERT MYERS PO Box 1829 Lake City, Florida 32056 United States		

**Taxpayer Information**

EIN ****1935	Type of Tax Applicable Federal Tax	Taxpayer Name ANDERSON COLUMBIA CO INC
Tax Year (Most Recent Tax Year) 2021	Name/Title of Individual Executing Consent Comptroller	TIN Consent Date Dec 2, 2022
Address PO Box 1829 Lake City, Florida 32056	Signature BERT MYERS	

**Points of Contact**

**Accounts Receivable POC**

2  
BERT MYERS  
bert@andersoncolumbia.com  
3867527585

**Electronic Business**

♂ JOSEPH G FIORE, PROJECT MANAGER joe.fiore@andersoncolumbia.com 8505753060	780 Business Park RD Midway, Florida 32343 United States
BERT MYERS bert@andersoncolumbia.com 3867527585	PO Box 1829 Lake City, Florida 32058 United States

**Government Business**

♂ JOSEPH G FIORE, PROJECT MANAGER joe.fiore@andersoncolumbia.com 8505752010	780 Business Park RD Midway, Florida 32343 United States
BERT MYERS bert@andersoncolumbia.com 3867527585	PO Box 1829 Lake City, Florida 32058 United States

**Past Performance**

♂ JOSEPH G FIORE, PROJECT MANAGER joe.fiore@andersoncolumbia.com 8505752010	780 Business Park RD Midway, Florida 32343 United States
BERT MYERS bert@andersoncolumbia.com 3867527585	PO Box 1829 Lake City, Florida 32058 United States

**Service Classifications**

**NAICS Codes**

Primary Yes	NAICS Codes 237310 324121	NAICS Title Highway, Street, And Bridge Construction Asphalt Paving Mixture And Block Manufacturing
----------------	---------------------------------	---

**Size Metrics**

**IGT Size Metrics**

Annual Revenue (from all IGTs)  
(blank)

**Worldwide**

Annual Receipts (in accordance with 13 CFR 121)	Number of Employees (in accordance with 13 CFR
\$300,000,000.00	121) 1200

**Location**

Annual Receipts (in accordance with 13 CFR 121)	Number of Employees (in accordance with 13 CFR
(blank)	121) (blank)

**Industry-Specific**

Barrels Capacity (blank)	Megawatt Hours (blank)	Total Assets (blank)
-----------------------------	---------------------------	-------------------------

**Electronic Data Interchange (EDI) Information**

This entity did not enter the EDI information

**Disaster Response**

Yes, this entity appears in the disaster response registry.

Bonding Levels	Dollars
(blank)	(blank)

States  
Alabama  
Florida  
Georgia

Counties  
(blank)

Metropolitan Statistical Areas  
(blank)

PROOF OF NO DELINQUENT TAXES OWED TO WEBB COUNTY

Name Berry O'Bryan owes no delinquent property taxes to Webb County.

Anderson Columbia Co., Inc. owes no property taxes as a business in Webb County.  
(Business Name)

Joe H. Anderson, III owes no property taxes as a resident of Webb County.  
(Business Owner)

  
Person who can attest to the above information

**\* SIGNED NOTORIZED DOCUMENT AND PROOF OF NO DELINQUENT TAXES TO WEBB COUNTY.**

The State of Texas  
County of Webb

Before me, a Notary Public, on this day personally appeared Berry O'Bryan, know to me (or proved to me on the oath of \_\_\_\_\_) to be the person whose name is subscribed to the forgoing instrument and acknowledged to me that he executed the same for the purpose and consideration therein expressed.

Given under my hand and seal of office this 11th day of April, 2023.

Notary Public, State of Texas

  
Maria Alicia Hernandez  
(Print name of Notary Public here)

My commission expires the 11th day of April, 2023.

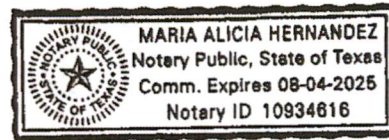

# Document A310™ – 2010

Conforms with The American Institute of Architects AIA Document 310

## Bid Bond

### CONTRACTOR:

(Name, legal status and address)

Anderson Columbia Co., Inc.  
2210 Vo Tech Dr.  
Weslaco, TX 78596-9024

### OWNER:

(Name, legal status and address)

Webb County TX  
1110 Washington Street  
Laredo, TX 78040

### SURETY:

(Name, legal status and principal place of business)

Travelers Casualty and Surety Company of America /  
Berkshire Hathaway Specialty Insurance Company

One Tower Square / 1314 Douglas Street, Suite 1400  
Hartford / Omaha, CT / NE 06183 / 68102-1944

### Mailing Address for Notices

same as above

This document has important legal consequences. Consultation with an attorney is encouraged with respect to its completion or modification.

Any singular reference to Contractor, Surety, Owner or other party shall be considered plural where applicable.

**BOND AMOUNT:** 5% Five Percent of Amount Bid

### PROJECT:

(Name, location or address, and Project number, if any)

ITB 2023-004 PUEBLO NUEVO STREET IMPROVEMENT PROJECT CONTRACT CDV21-0485, WEBB COUNTY, TX

The Contractor and Surety are bound to the Owner in the amount set forth above, for the payment of which the Contractor and Surety bind themselves, their heirs, executors, administrators, successors and assigns, jointly and severally, as provided herein. The conditions of this Bond are such that if the Owner accepts the bid of the Contractor within the time specified in the bid documents, or within such time period as may be agreed to by the Owner and Contractor, and the Contractor either (1) enters into a contract with the Owner in accordance with the terms of such bid, and gives such bond or bonds as may be specified in the bidding or Contract Documents, with a surety admitted in the jurisdiction of the Project and otherwise acceptable to the Owner, for the faithful performance of such Contract and for the prompt payment of labor and material furnished in the prosecution thereof; or (2) pays to the Owner the difference, not to exceed the amount of this Bond, between the amount specified in said bid and such larger amount for which the Owner may in good faith contract with another party to perform the work covered by said bid, then this obligation shall be null and void, otherwise to remain in full force and effect. The Surety hereby waives any notice of an agreement between the Owner and Contractor to extend the time in which the Owner may accept the bid. Waiver of notice by the Surety shall not apply to any extension exceeding sixty (60) days in the aggregate beyond the time for acceptance of bids specified in the bid documents, and the Owner and Contractor shall obtain the Surety's consent for an extension beyond sixty (60) days.

If this Bond is issued in connection with a subcontractor's bid to a Contractor, the term Contractor in this Bond shall be deemed to be Subcontractor and the term Owner shall be deemed to be Contractor.

When this Bond has been furnished to comply with a statutory or other legal requirement in the location of the Project, any provision in this Bond conflicting with said statutory or legal requirement shall be deemed deleted herefrom and provisions conforming to such statutory or other legal requirement shall be deemed incorporated herein. When so furnished, the intent is that this Bond shall be construed as a statutory bond and not as a common law bond.

Signed and sealed this 11th day of April, 2023.

Anderson Columbia Co., Inc.

(Principal)

(Seal)

(Witness)

By:

(Title)

Travelers Casualty and Surety Company of America / Berkshire Hathaway Specialty Insurance Company

(Surety)

By:

(Title) Kevin R. Wojtowicz, Attorney-in-Fact

  
(Witness) Amy Scott

S-0054/AS 8/10

Exhibit A

Construction Contract Pueblo Nuevo Street Improvement Project Contract CDV21-0485 (I.T.B. 2023-004)

Webb County, Owner – Anderson Columbia Co., Inc., Contractor

Page 27 of 35





**Travelers Casualty and Surety Company of America  
Travelers Casualty and Surety Company  
St. Paul Fire and Marine Insurance Company**

**POWER OF ATTORNEY**

**KNOW ALL MEN BY THESE PRESENTS**, That Travelers Casualty and Surety Company of America, Travelers Casualty and Surety Company, and St Paul Fire and Marine Insurance Company are corporations duly organized under the laws of the State of Connecticut (herein collectively called the "Companies"), and that the Companies do hereby make, constitute and appoint **KEVIN R WOJTOWICZ** of **ST PETERSBURG Florida** their true and lawful Attorney(s)-in-Fact to sign, execute, seal and acknowledge any and all bonds, recognizances, conditional undertakings and other writings obligatory in the nature thereof on behalf of the Companies in their business of guaranteeing the fidelity of persons, guaranteeing the performance of contracts and executing or guaranteeing bonds and undertakings required or permitted in any actions or proceedings allowed by law.

**IN WITNESS WHEREOF**, the Companies have caused this instrument to be signed, and their corporate seals to be hereto affixed, this **21st** day of **April**, 2021.



State of Connecticut

City of Hartford ss.

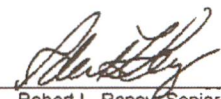
By:   
Robert L. Raney, Senior Vice President

On this the **21st** day of **April**, 2021, before me personally appeared **Robert L. Raney**, who acknowledged himself to be the Senior Vice President of each of the Companies, and that he, as such, being authorized so to do, executed the foregoing instrument for the purposes therein contained by signing on behalf of said Companies by himself as a duly authorized officer.

**IN WITNESS WHEREOF**, I hereunto set my hand and official seal.

My Commission expires the **30th** day of **June**, 2026



  
Anna P. Nowik, Notary Public

This Power of Attorney is granted under and by the authority of the following resolutions adopted by the Boards of Directors of each of the Companies, which resolutions are now in full force and effect, reading as follows:

**RESOLVED**, that the Chairman, the President, any Vice Chairman, any Executive Vice President, any Senior Vice President, any Vice President, any Second Vice President, the Treasurer, any Assistant Treasurer, the Corporate Secretary or any Assistant Secretary may appoint Attorneys-in-Fact and Agents to act for and on behalf of the Company and may give such appointee such authority as his or her certificate of authority may prescribe to sign with the Company's name and seal with the Company's seal bonds, recognizances, contracts of indemnity, and other writings obligatory in the nature of a bond, recognizance, or conditional undertaking, and any of said officers or the Board of Directors at any time may remove any such appointee and revoke the power given him or her; and it is

**FURTHER RESOLVED**, that the Chairman, the President, any Vice Chairman, any Executive Vice President, any Senior Vice President or any Vice President may delegate all or any part of the foregoing authority to one or more officers or employees of this Company, provided that each such delegation is in writing and a copy thereof is filed in the office of the Secretary; and it is

**FURTHER RESOLVED**, that any bond, recognizance, contract of indemnity, or writing obligatory in the nature of a bond, recognizance, or conditional undertaking shall be valid and binding upon the Company when (a) signed by the President, any Vice Chairman, any Executive Vice President, any Senior Vice President or any Vice President, any Second Vice President, the Treasurer, any Assistant Treasurer, the Corporate Secretary or any Assistant Secretary and duly attested and sealed with the Company's seal by a Secretary or Assistant Secretary; or (b) duly executed (under seal, if required) by one or more Attorneys-in-Fact and Agents pursuant to the power prescribed in his or her certificate or their certificates of authority or by one or more Company officers pursuant to a written delegation of authority; and it is

**FURTHER RESOLVED**, that the signature of each of the following officers: President, any Executive Vice President, any Senior Vice President, any Vice President, any Assistant Vice President, any Secretary, any Assistant Secretary, and the seal of the Company may be affixed by facsimile to any Power of Attorney or to any certificate relating thereto appointing Resident Vice Presidents, Resident Assistant Secretaries or Attorneys-in-Fact for purposes only of executing and attesting bonds and undertakings and other writings obligatory in the nature thereof, and any such Power of Attorney or certificate bearing such facsimile signature or facsimile seal shall be valid and binding upon the Company and any such power so executed and certified by such facsimile signature and facsimile seal shall be valid and binding on the Company in the future with respect to any bond or understanding to which it is attached.

I, **Kevin E. Hughes**, the undersigned, Assistant Secretary of each of the Companies, do hereby certify that the above and foregoing is a true and correct copy of the Power of Attorney executed by said Companies, which remains in full force and effect.

Dated this **11th** day of **April**, 2023



  
Kevin E. Hughes, Assistant Secretary

**To verify the authenticity of this Power of Attorney, please call us at 1-800-421-3880.  
Please refer to the above-named Attorney(s)-in-Fact and the details of the bond to which this Power of Attorney is attached.**





Power Of Attorney

BERKSHIRE HATHAWAY SPECIALTY INSURANCE COMPANY
NATIONAL INDEMNITY COMPANY / NATIONAL LIABILITY & FIRE INSURANCE COMPANY

Know all men by these presents, that BERKSHIRE HATHAWAY SPECIALTY INSURANCE COMPANY, a corporation existing under and by virtue of the laws of the State of Nebraska and having an office at One Lincoln Street, 23rd Floor, Boston, Massachusetts 02111, NATIONAL INDEMNITY COMPANY, a corporation existing under and by virtue of the laws of the State of Nebraska and having an office at 3024 Harney Street, Omaha, Nebraska 68131 and NATIONAL LIABILITY & FIRE INSURANCE COMPANY, a corporation existing under and by virtue of the laws of the State of Connecticut and having an office at 100 First Stamford Place, Stamford, Connecticut 06902 (hereinafter collectively the "Companies"), pursuant to and by the authority granted as set forth herein, do hereby name, constitute and appoint: Kevin R. Woltowicz, 1000 Central Avenue, Suite 200 of the city of St. Petersburg, State of Florida, their true and lawful attorney(s)-in-fact to make, execute, seal, acknowledge, and deliver, for and on their behalf as surety and as their act and deed, any and all undertakings, bonds, or other such writings obligatory in the nature thereof, in pursuance of these presents, the execution of which shall be as binding upon the Companies as if it has been duly signed and executed by their regularly elected officers in their own proper persons. This authority for the Attorney-in-Fact shall be limited to the execution of the attached bond(s) or other such writings obligatory in the nature thereof.

In witness whereof, this Power of Attorney has been subscribed by an authorized officer of the Companies, and the corporate seals of the Companies have been affixed hereto this date of December 20, 2018. This Power of Attorney is made and executed pursuant to and by authority of the Bylaws, Resolutions of the Board of Directors, and other Authorizations of BERKSHIRE HATHAWAY SPECIALTY INSURANCE COMPANY, NATIONAL INDEMNITY COMPANY and NATIONAL LIABILITY & FIRE INSURANCE COMPANY, which are in full force and effect, each reading as appears on the back page of this Power of Attorney, respectively. The following signature by an authorized officer of the Company may be a facsimile, which shall be deemed the equivalent of and constitute the written signature of such officer of the Company for all purposes regarding this Power of Attorney, including satisfaction of any signature requirements on any and all undertakings, bonds, or other such writings obligatory in the nature thereof, to which this Power of Attorney applies.

BERKSHIRE HATHAWAY SPECIALTY INSURANCE COMPANY,

[Signature of David Fields]

By: David Fields, Executive Vice President



NATIONAL INDEMNITY COMPANY, NATIONAL LIABILITY & FIRE INSURANCE COMPANY,

[Signature of David Fields]

By: David Fields, Vice President



NOTARY

State of Massachusetts, County of Suffolk, ss:

On this 20th day of December, 2018, before me appeared David Fields, Executive Vice President of BERKSHIRE HATHAWAY SPECIALTY INSURANCE COMPANY and Vice President of NATIONAL INDEMNITY COMPANY and NATIONAL LIABILITY & FIRE INSURANCE COMPANY, who being duly sworn, says that his capacity is as designated above for such Companies, that he knows the corporate seals of the Companies; that the seals affixed to the foregoing instrument are such corporate seals; that they were affixed by order of the board of directors or other governing body of said Companies pursuant to its Bylaws, Resolutions and other Authorizations, and that he signed said instrument in that capacity of said Companies.

[Notary Seal]

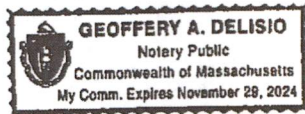

[Signature of Notary Public]

Notary Public

I, Ralph Tortorella, the undersigned, Officer of BERKSHIRE HATHAWAY SPECIALTY INSURANCE COMPANY, NATIONAL INDEMNITY COMPANY and NATIONAL LIABILITY & FIRE INSURANCE COMPANY, do hereby certify that the above and foregoing is a true and correct copy of the Power of Attorney executed by said Companies which is in full force and effect and has not been revoked. IN TESTIMONY WHEREOF, see hereunto affixed the seals of said Companies this April 11, 2023.



[Signature of Ralph Tortorella]
Officer

BHSIC, NICO & NLF POA (2018)

Exhibit A

Construction Contract Pueblo Nuevo Street Improvement Project Contract CDV21-0485 (I.T.B. 2023-004)

Webb County, Owner - Anderson Columbia Co., Inc., Contractor

Page 29 of 35

To verify the authenticity of this Power of Attorney please contact us at: BHSI Surety Department, Berkshire Hathaway Specialty Insurance Company, One Lincoln Street, 23rd Floor Boston, MA 02111 | (770) 625-2516 or by email at Jennifer.Porter@bhsispecialty.com THIS POWER OF ATTORNEY IS VOID IF ALTERED To notify us of a claim please contact us on our 24-hour toll free number at (855) 453-9675, via email at claims@bhsispecialty.com, via fax to (617) 507-8259, or via mail.

# Document A310™ – 2010

Conforms with The American Institute of Architects AIA Document 310

## Bid Bond

### CONTRACTOR:

(Name, legal status and address)

Anderson Columbia Co., Inc.  
2210 Vo Tech Dr.  
Weslaco, TX 78596-9024

### OWNER:

(Name, legal status and address)

Webb County TX  
1110 Washington Street  
Laredo, TX 78040

### SURETY:

(Name, legal status and principal place of business)

Travelers Casualty and Surety Company of America /  
Berkshire Hathaway Specialty Insurance Company

One Tower Square / 1314 Douglas Street, Suite 1400  
Hartford / Omaha, CT / NE 06183 / 68102-1944

### Mailing Address for Notices

same as above

This document has important legal consequences. Consultation with an attorney is encouraged with respect to its completion or modification.

Any singular reference to Contractor, Surety, Owner or other party shall be considered plural where applicable.

**BOND AMOUNT:** 5% Five Percent of Amount Bid

### PROJECT:

(Name, location or address, and Project number, if any)

ITB 2023-004 PUEBLO NUEVO STREET IMPROVEMENT PROJECT CONTRACT CDV21-0485, WEBB COUNTY, TX

The Contractor and Surety are bound to the Owner in the amount set forth above, for the payment of which the Contractor and Surety bind themselves, their heirs, executors, administrators, successors and assigns, jointly and severally, as provided herein. The conditions of this Bond are such that if the Owner accepts the bid of the Contractor within the time specified in the bid documents, or within such time period as may be agreed to by the Owner and Contractor, and the Contractor either (1) enters into a contract with the Owner in accordance with the terms of such bid, and gives such bond or bonds as may be specified in the bidding or Contract Documents, with a surety admitted in the jurisdiction of the Project and otherwise acceptable to the Owner, for the faithful performance of such Contract and for the prompt payment of labor and material furnished in the prosecution thereof; or (2) pays to the Owner the difference, not to exceed the amount of this Bond, between the amount specified in said bid and such larger amount for which the Owner may in good faith contract with another party to perform the work covered by said bid, then this obligation shall be null and void, otherwise to remain in full force and effect. The Surety hereby waives any notice of an agreement between the Owner and Contractor to extend the time in which the Owner may accept the bid. Waiver of notice by the Surety shall not apply to any extension exceeding sixty (60) days in the aggregate beyond the time for acceptance of bids specified in the bid documents, and the Owner and Contractor shall obtain the Surety's consent for an extension beyond sixty (60) days.

If this Bond is issued in connection with a subcontractor's bid to a Contractor, the term Contractor in this Bond shall be deemed to be Subcontractor and the term Owner shall be deemed to be Contractor.

When this Bond has been furnished to comply with a statutory or other legal requirement in the location of the Project, any provision in this Bond conflicting with said statutory or legal requirement shall be deemed deleted herefrom and provisions conforming to such statutory or other legal requirement shall be deemed incorporated herein. When so furnished, the intent is that this Bond shall be construed as a statutory bond and not as a common law bond.

Signed and sealed this 11th day of April, 2023.

Anderson Columbia Co., Inc.

(Principal)

(Seal)

(Witness)

By:

(Title)

Travelers Casualty and Surety Company of America / Berkshire Hathaway Specialty Insurance Company

(Surety)

(Seal)

Amy Scott

(Witness) Amy Scott

By:

(Title) Kevin R. Wojtowicz, Attorney-in-Fact

S-0054/AS 8/10

Exhibit A

Construction Contract Pueblo Nuevo Street Improvement Project Contract CDV21-0485 (I.T.B. 2023-004)

Webb County, Owner – Anderson Columbia Co., Inc., Contractor

Page 30 of 35





**Travelers Casualty and Surety Company of America**  
**Travelers Casualty and Surety Company**  
**St. Paul Fire and Marine Insurance Company**

**POWER OF ATTORNEY**

**KNOW ALL MEN BY THESE PRESENTS:** That Travelers Casualty and Surety Company of America, Travelers Casualty and Surety Company, and St. Paul Fire and Marine Insurance Company are corporations duly organized under the laws of the State of Connecticut (herein collectively called the "Companies"), and that the Companies do hereby make, constitute and appoint **KEVIN R WOJTOWICZ** of **ST PETERSBURG Florida** their true and lawful Attorney(s)-in-Fact to sign, execute, seal and acknowledge any and all bonds, recognizances, conditional undertakings and other writings obligatory in the nature thereof on behalf of the Companies in their business of guaranteeing the fidelity of persons, guaranteeing the performance of contracts and executing or guaranteeing bonds and undertakings required or permitted in any actions or proceedings allowed by law.

**IN WITNESS WHEREOF**, the Companies have caused this instrument to be signed, and their corporate seals to be hereto affixed, this **21st** day of **April**, 2021.



State of Connecticut

City of Hartford ss.

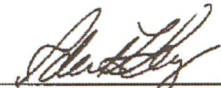
By:   
 Robert L. Raney, Senior Vice President

On this the **21st** day of **April**, 2021, before me personally appeared **Robert L. Raney**, who acknowledged himself to be the Senior Vice President of each of the Companies, and that he, as such, being authorized so to do, executed the foregoing instrument for the purposes therein contained by signing on behalf of said Companies by himself as a duly authorized officer.

**IN WITNESS WHEREOF**, I hereunto set my hand and official seal.

My Commission expires the **30th** day of **June**, 2026



  
 Anna P. Nowik, Notary Public

This Power of Attorney is granted under and by the authority of the following resolutions adopted by the Boards of Directors of each of the Companies, which resolutions are now in full force and effect, reading as follows:

**RESOLVED**, that the Chairman, the President, any Vice Chairman, any Executive Vice President, any Senior Vice President, any Vice President, any Second Vice President, the Treasurer, any Assistant Treasurer, the Corporate Secretary or any Assistant Secretary may appoint Attorneys-in-Fact and Agents to act for and on behalf of the Company and may give such appointee such authority as his or her certificate of authority may prescribe to sign with the Company's name and seal with the Company's seal bonds, recognizances, contracts of indemnity, and other writings obligatory in the nature of a bond, recognizance, or conditional undertaking, and any of said officers or the Board of Directors at any time may remove any such appointee and revoke the power given him or her; and it is

**FURTHER RESOLVED**, that the Chairman, the President, any Vice Chairman, any Executive Vice President, any Senior Vice President or any Vice President may delegate all or any part of the foregoing authority to one or more officers or employees of this Company, provided that each such delegation is in writing and a copy thereof is filed in the office of the Secretary; and it is

**FURTHER RESOLVED**, that any bond, recognizance, contract of indemnity, or writing obligatory in the nature of a bond, recognizance, or conditional undertaking shall be valid and binding upon the Company when (a) signed by the President, any Vice Chairman, any Executive Vice President, any Senior Vice President or any Vice President, any Second Vice President, the Treasurer, any Assistant Treasurer, the Corporate Secretary or any Assistant Secretary and duly attested and sealed with the Company's seal by a Secretary or Assistant Secretary; or (b) duly executed (under seal, if required) by one or more Attorneys-in-Fact and Agents pursuant to the power prescribed in his or her certificate or their certificates of authority or by one or more Company officers pursuant to a written delegation of authority; and it is

**FURTHER RESOLVED**, that the signature of each of the following officers: President, any Executive Vice President, any Senior Vice President, any Vice President, any Assistant Vice President, any Secretary, any Assistant Secretary, and the seal of the Company may be affixed by facsimile to any Power of Attorney or to any certificate relating thereto appointing Resident Vice Presidents, Resident Assistant Secretaries or Attorneys-in-Fact for purposes only of executing and attesting bonds and undertakings and other writings obligatory in the nature thereof, and any such Power of Attorney or certificate bearing such facsimile signature or facsimile seal shall be valid and binding upon the Company and any such power so executed and certified by such facsimile signature and facsimile seal shall be valid and binding on the Company in the future with respect to any bond or understanding to which it is attached.

I, **Kevin E. Hughes**, the undersigned, Assistant Secretary of each of the Companies, do hereby certify that the above and foregoing is a true and correct copy of the Power of Attorney executed by said Companies, which remains in full force and effect.

Dated this **11th** day of **April**, 2023



  
 Kevin E. Hughes, Assistant Secretary

**To verify the authenticity of this Power of Attorney, please call us at 1-800-421-3880.**  
**Please refer to the above-named Attorney(s)-in-Fact and the details of the bond to which this Power of Attorney is attached.**





Power Of Attorney

BERKSHIRE HATHAWAY SPECIALTY INSURANCE COMPANY NATIONAL INDEMNITY COMPANY / NATIONAL LIABILITY & FIRE INSURANCE COMPANY

Know all men by these presents, that BERKSHIRE HATHAWAY SPECIALTY INSURANCE COMPANY, a corporation existing under and by virtue of the laws of the State of Nebraska and having an office at One Lincoln Street, 23rd Floor, Boston, Massachusetts 02111, NATIONAL INDEMNITY COMPANY, a corporation existing under and by virtue of the laws of the State of Nebraska and having an office at 3024 Harney Street, Omaha, Nebraska 68131 and NATIONAL LIABILITY & FIRE INSURANCE COMPANY, a corporation existing under and by virtue of the laws of the State of Connecticut and having an office at 100 First Stamford Place, Stamford, Connecticut 06902 (hereinafter collectively the "Companies"), pursuant to and by the authority granted as set forth herein, do hereby name, constitute and appoint: Kevin R. Woltowicz, 1000 Central Avenue, Suite 200 of the city of St. Petersburg, State of Florida, their true and lawful attorney(s)-in-fact to make, execute, seal, acknowledge, and deliver, for and on their behalf as surety and as their act and deed, any and all undertakings, bonds, or other such writings obligatory in the nature thereof, in pursuance of these presents, the execution of which shall be as binding upon the Companies as if it has been duly signed and executed by their regularly elected officers in their own proper persons. This authority for the Attorney-in-Fact shall be limited to the execution of the attached bond(s) or other such writings obligatory in the nature thereof.

In witness whereof, this Power of Attorney has been subscribed by an authorized officer of the Companies, and the corporate seals of the Companies have been affixed hereto this date of December 20, 2018. This Power of Attorney is made and executed pursuant to and by authority of the Bylaws, Resolutions of the Board of Directors, and other Authorizations of BERKSHIRE HATHAWAY SPECIALTY INSURANCE COMPANY, NATIONAL INDEMNITY COMPANY and NATIONAL LIABILITY & FIRE INSURANCE COMPANY, which are in full force and effect, each reading as appears on the back page of this Power of Attorney, respectively. The following signature by an authorized officer of the Company may be a facsimile, which shall be deemed the equivalent of and constitute the written signature of such officer of the Company for all purposes regarding this Power of Attorney, including satisfaction of any signature requirements on any and all undertakings, bonds, or other such writings obligatory in the nature thereof, to which this Power of Attorney applies.

BERKSHIRE HATHAWAY SPECIALTY INSURANCE COMPANY,

[Signature of David Fields]

By: David Fields, Executive Vice President



NATIONAL INDEMNITY COMPANY, NATIONAL LIABILITY & FIRE INSURANCE COMPANY,

[Signature of David Fields]

By: David Fields, Vice President



NOTARY

State of Massachusetts, County of Suffolk, ss.

On this 20th day of December, 2018, before me appeared David Fields, Executive Vice President of BERKSHIRE HATHAWAY SPECIALTY INSURANCE COMPANY and Vice President of NATIONAL INDEMNITY COMPANY and NATIONAL LIABILITY & FIRE INSURANCE COMPANY, who being duly sworn, says that his capacity is as designated above for such Companies; that he knows the corporate seals of the Companies; that the seals affixed to the foregoing instrument are such corporate seals; that they were affixed by order of the board of directors or other governing body of said Companies pursuant to its Bylaws, Resolutions and other Authorizations, and that he signed said instrument in that capacity of said Companies.

[Notary Seal]

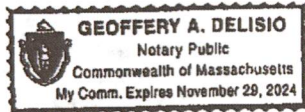

[Signature of Geoffrey A. Delisio]

Notary Public

I, Ralph Tortorella, the undersigned, Officer of BERKSHIRE HATHAWAY SPECIALTY INSURANCE COMPANY, NATIONAL INDEMNITY COMPANY and NATIONAL LIABILITY & FIRE INSURANCE COMPANY, do hereby certify that the above and foregoing is a true and correct copy of the Power of Attorney executed by said Companies which is in full force and effect and has not been revoked. IN TESTIMONY WHEREOF, see hereunto affixed the seals of said Companies this April 11, 2023.



[Signature of Ralph Tortorella]

Officer

To verify the authenticity of this Power of Attorney please contact us at: BHSISurety Department, Berkshire Hathaway Specialty Insurance Company, One Lincoln Street, 23rd Floor Boston, MA 02111 | (770) 625-2516 or by email at Jennifer.Porter@bhspecialty.com THIS POWER OF ATTORNEY IS VOID IF ALTERED To notify us of a claim please contact us on our 24-hour toll free number at (855) 453-9675, via email at claims@bhspecialty.com, via fax to (617) 507-8259, or via mail.



**Office of the Secretary of State**

**CERTIFICATE OF FILING  
OF**

**ANDERSON COLUMBIA CO., INC.**  
File Number: 10624006

The undersigned, as Secretary of State of Texas, hereby certifies that the application for reinstatement for the above named entity has been received in this office and has been found to conform to law. It is further certified that the entity has been reinstated to active status on the records of this office.

ACCORDINGLY the undersigned, as Secretary of State, and by virtue of the authority vested in the Secretary by law hereby issues this Certificate of Filing.

Dated: 07/08/2008

Effective: 07/08/2008



A handwritten signature in black ink that reads "Phil Wilson".

Phil Wilson  
Secretary of State

Phone: (512) 463-5555  
Prepared by: Lisa Jones

*Come visit us on the internet at <http://www.sos.state.tx.us/>*  
Fax: (512) 463-5709  
TID: 10011

Dial: 7-1-1 for Relay Services  
Document: 221475790002



CERTIFIED COPY OF RESOLUTION OF  
BOARD OF DIRECTORS OF  
ANDERSON COLUMBIA CO., INC.

I hereby certify that a meeting, duly called, of the Board of Directors of Anderson Columbia Co., Inc., a Florida Corporation, held the 1st day of March, 2010 at which said meeting a quorum was present and acting throughout, the following preamble and resolution was adopted and ever since has been and now is full force and effect and does not conflict with the by-laws of said Corporation:

Berry O'Bryan is hereby authorized to execute and submit proposals, supplemental, change orders, contracts, bid bonds and other related documents on behalf of Anderson Columbia Co., Inc. The proposals, bid bond, etc... and other such instruments signed by him shall be binding upon said corporation as it own acts and deeds.

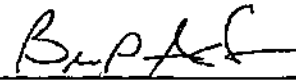

Brian P. Schreiber, Corporate Secretary

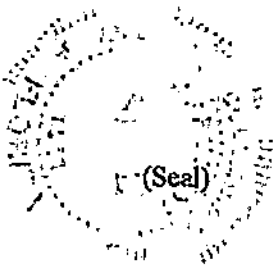

**Proposal**  
**ANDERSON COLUMBIA CO., INC.**

Job Code: TX 2023 04 11 Webb Pueblo Nuevo Paving REVISED1  
 Description: REVISED Flex Base 5 IN, HMA D 1.5 IN

Line No.	Pay Item No.	Description Subtotal Description	Quantity	Unit of Measure	Unit Price	Total Price
1	110 6001	WEST MEIRS - EXCAVATION (ROADWAY)	658.00	CY	47.00	30,926.00
2	247 6044	WEST MEIRS - FL BS (CMP IN PLC) (TY D) (FINAL POS)	658.00	CY	130.00	85,540.00
3	3076 6042	WEST MEIRS - D-GR HMA (SQ) TY-D SAC-B PG70-22	315.00	Ton	190.00	59,850.00
4	310 6009	WEST MEIRS - PRIME COAT MC-30	900.00	GAL	8.00	7,200.00
5	500 6001	WEST MEIRS - MOBILIZATION	1.00	LS	42,249	42,249
6	502 6001	WEST MEIRS - BARRICADES, SIGNS AND TRAFFIC HANDLING	1.00	MO	5,000.00	5,000.00
7	636 6001	WEST MEIRS - ALUMINUM SIGNS (TY A)	1.00	EA	1,800.00	1,800.00
8	666 6047	WEST MEIRS - REFL PAV MRK TY I (W)24" (SLD)(090MIL)	12.00	LF	50.00	600.00
9	690 0000	WEST MEIRS - 4'X8' PROJECT SIGN	1.00	EA	2,000.00	2,000.00
101	110 6001	WEST PAREDES - EXCAVATION (ROADWAY)	575.00	CY	47.00	27,025.00
102	247 6044	WEST PAREDES - FL BS (CMP IN PLC) (TY D) (FINAL POS)	575.00	CY	130.00	74,750.00
103	3076 6042	WEST PAREDES - D-GR HMA (SQ) TY-D SAC-B PG70-22	285.00	Ton	190.00	54,150.00
104	310 6009	WEST PAREDES - PRIME COAT MC-30	750.00	GAL	8.00	6,000.00
105	502 6001	WEST PAREDES - BARRICADES, SIGNS AND TRAFFIC HANDLING	1.00	LS	5,000.00	5,000.00
106	636 6001	WEST PAREDES - ALUMINUM SIGNS (TY A)	1.00	MO	1,800.00	1,800.00
107	666 6047	WEST PAREDES - REFL PAV MRK TY I (W)24" (SLD)(090MIL)	12.00	EA	50.00	600.00

**GRAND TOTAL: \$404,490**

**Proposal Certification**

Signed: \_\_\_\_\_

Title: \_\_\_\_\_

Date: \_\_\_\_\_

  
 Senior Project Manager

4/25/2023

# CONSTRUCTION PLANS FOR PUEBLO NUEVO PAVING PROJECT

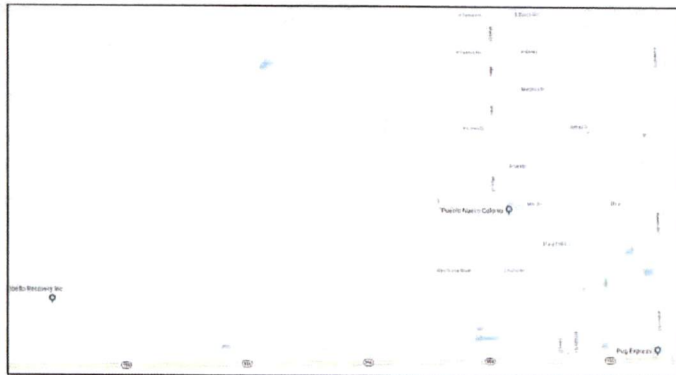

  
 N  
 LOCATION MAP—PUEBLO NUEVO

TANO E. TIJERINA	COUNTY JUDGE
JESSE GONZALEZ	PRECINCT I
ROSAURO "WAWI" TIJERINA	PRECINCT II
JOHN GALO	PRECINCT III
RICARDO A. JAIME	PRECINCT IV
LUIS PEREZ GARCIA, P.E., C.F.M. COUNTY ENGINEER	

SUBMITTED BY: Guillermo B. Cuellar, P.E.      4/20/2023  
 GUILLERMO B. CUELLAR, P.E.      DATES



**2023**

<b>WEBB COUNTY ENGINEERING</b>			
<b>PUEBLO NUEVO PAVING PROJECT</b>			
<b>COVER SHEET</b>			
PAGE	1	OF	

WEST MEIRS			
ITEM NO	ITEM DESCRIPTION	UNITS	QUANTITY
1	EXCAVATION (ROADWAY)	CY	658
2	FLEX BASE TYPE D	CY	658
3	D-GR HMA(SQ) TY-D SAC-B PG70-22	TON	315
4	PRIME COAT MC-30	GAL	900
5	MOBILIZATION	LS	1
6	BARRICADES, SIGNS AND TRAFFIC HANDLING	MO	1
7	ALUMINUM SIGNS (TY A)	EA	1
8	REFL PAV MRK TY I (W)24"(SLD)(090MIL)	LF	12
9	4'X8' PROJECT SIGN	EA	1

WEST PAREDES			
ITEM NO	ITEM DESCRIPTION	UNITS	QUANTITY
1	EXCAVATION (ROADWAY)	CY	575
2	FLEX BASE TYPE D	CY	575
3	D-GR HMA(SQ) TY-D SAC-B PG70-22	TON	285
4	PRIME COAT MC-30	GAL	750
5	BARRICADES, SIGNS AND TRAFFIC HANDLING	MO	1
6	ALUMINUM SIGNS (TY A)	EA	1
7	REFL PAV MRK TY I (W)24"(SLD)(090MIL)	LF	12

WEBB COUNTY ENGINEERING			
PUEBLO NUEVO PAVING PROJECT			
QUANTITY SHEET			
PAGE	2	OF	

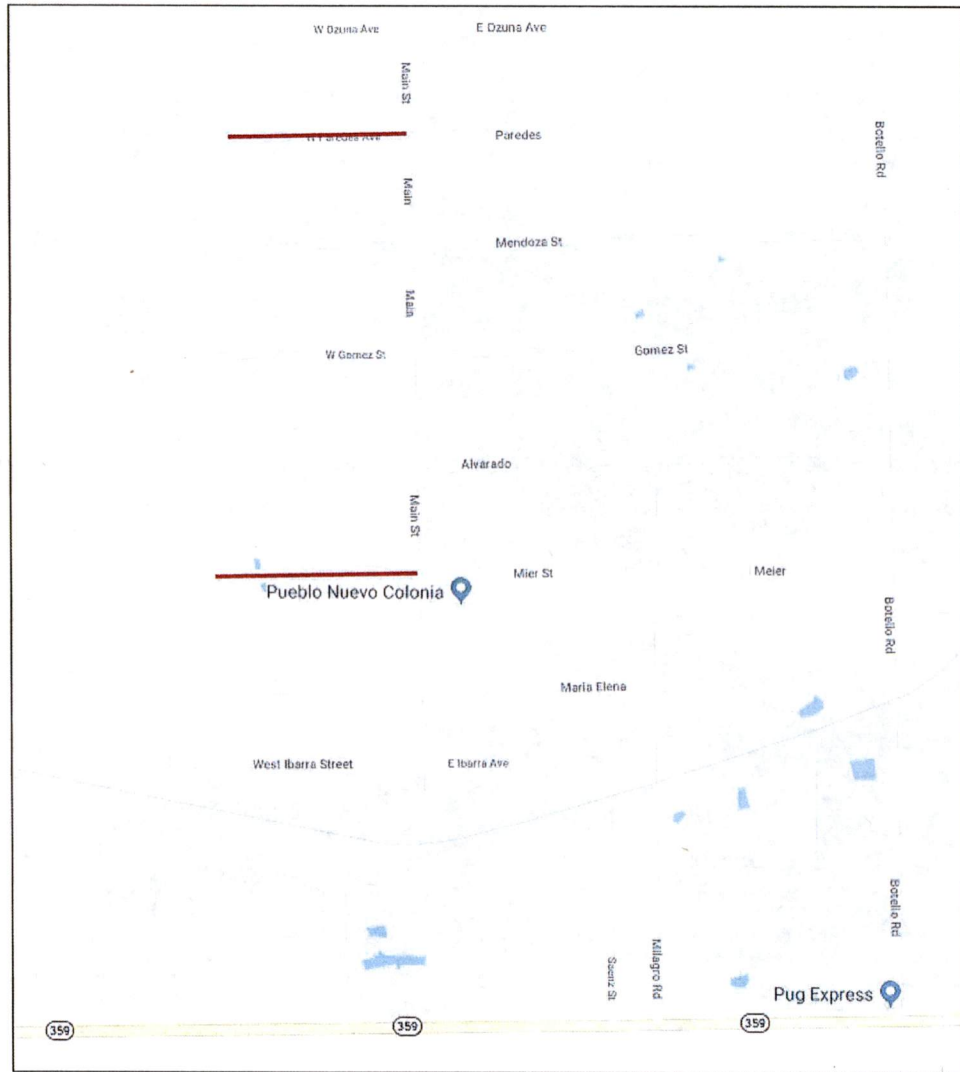

Street Location —————

WEBB COUNTY ENGINEERING			
PUEBLO NUEVO PAVING PROJECT			
LOCATION			
PAGE	3	OF	

# PUEBLO NUEVO FINAL PROJECT MAP

## 2. West Meirs Street

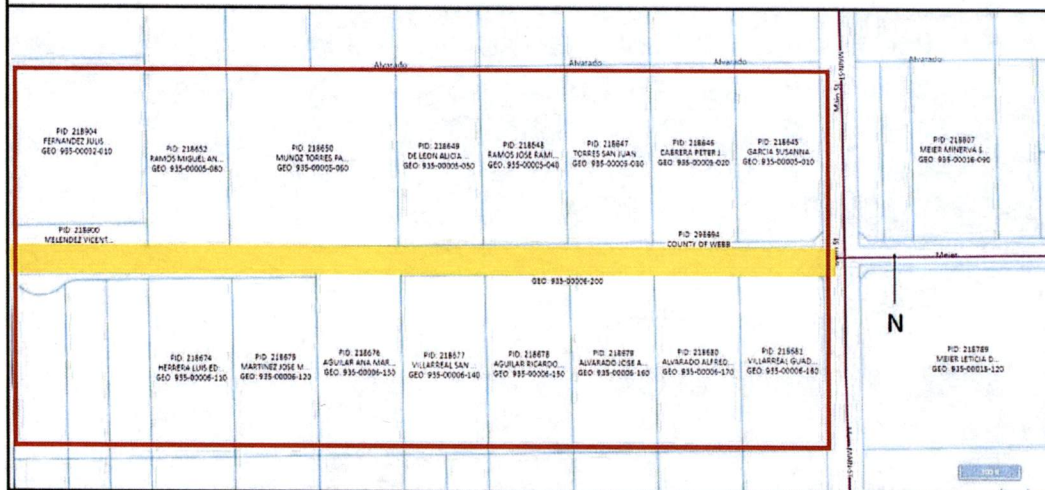

**LEGEND OF PAVED AREAS:**

- West Meirs Street 
- Serviced Area 

Drawing By: Guillermo B. Cuellar, P.E.  
Webb County Engineering Department

WEBB COUNTY ENGINEERING			
PUEBLO NUEVO PAVING PROJECT			
LOCATION			
PAGE	4	OF	





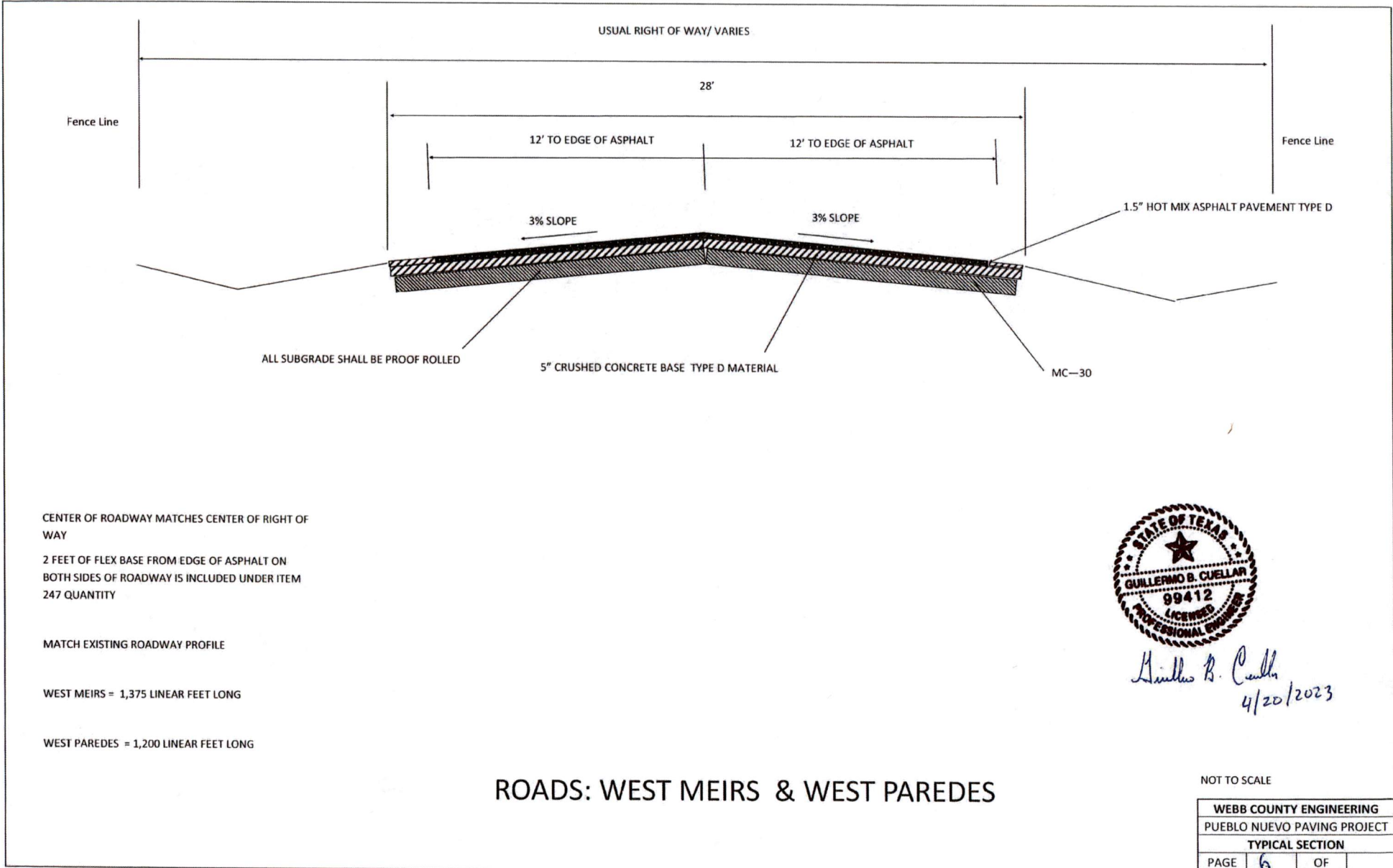

CENTER OF ROADWAY MATCHES CENTER OF RIGHT OF WAY

2 FEET OF FLEX BASE FROM EDGE OF ASPHALT ON BOTH SIDES OF ROADWAY IS INCLUDED UNDER ITEM 247 QUANTITY

MATCH EXISTING ROADWAY PROFILE

WEST MEIRS = 1,375 LINEAR FEET LONG

WEST PAREDES = 1,200 LINEAR FEET LONG



*Guillermo B. Cuellar*  
4/20/2023

# ROADS: WEST MEIRS & WEST PAREDES

NOT TO SCALE

WEBB COUNTY ENGINEERING			
PUEBLO NUEVO PAVING PROJECT			
TYPICAL SECTION			
PAGE	6	OF	

**ROAD NOTES**

PRIOR TO ANY ASPHALT, THE CONTRACTOR SHALL SUBMIT TO THE ENGINEER FOR APPROVAL A HOT-MIX ASPHALT DESIGN AND SHALL GIVE ASSURANCE THAT THE STOCKPILES OF MATERIALS ARE SUFFICIENT TO PRODUCE THE SAME DESIGN FOR THE DURATION OF THE PROJECT. IF MATERIALS SOURCE CHANGES, A NEW DESIGN WILL BE REQUIRED AT THE CONTRACTOR'S EXPENSE.

AT THE END OF THE PAVING DAY, ALL LANES IN A GIVEN ROAD SECTION SHALL BE COMPLETED TO APPROXIMATELY THE SAME STATION AND THE CONTRACTOR SHALL ENSURE THAT ALL HOT-MIX LAYING HAS BEEN CONSTRUCTED IN A CONTINUOUS MANNER THROUGHOUT THE ROADWAY SURFACE. TRANSVERSE JOINTS DURING THE LAYING OF ASPHALT SHALL BE APPROVED BY THE ENGINEER.

CONTRACTOR SHALL ADJUST AND OR SAWCUT EXISTING PAVEMENT AS NECESSARY TO ASSURE A SMOOTH AND CONTINUOUS TRANSITION GRADE.

ANY EXISTING DRIVEWAY DISTURBED BY THE CONTRACTOR SHALL BE REMOVED AND RESTORED WITH SURFACE MATERIALS EQUAL TO OR BETTER THAN THE ORIGINAL.

THE CONTRACTOR SHALL MAINTAIN ALL ADJOINING ROADS, DRIVEWAYS AND TRAVELLED ROUTES FREE FROM SPILLED AND OR TRACKED CONSTRUCTION MATERIALS AND DEBRIS.

**PERMIT NOTES**

ALL ASSOCIATED PERMITS AND FEES SHALL BE THE SOLE RESPONSIBILITY OF THE CONTRACTOR. PRIOR TO ANY CONSTRUCTION, THE CONTRACTOR SHALL APPLY FOR AND SECURE ALL PROPER PERMITS FROM THE APPROPRIATE AUTHORITIES.

THE CONTRACTOR SHALL NOT PLACE ANY WASTE MATERIAL IN THE 100-YEAR FLOOD PLAIN WITHOUT FIRST OBTAINING AND APPROVED FLOOD PLAIN DEVELOPMENT PERMIT IF APPLICABLE.

**TESTING NOTES**

ALL TESTING REQUIRED BY THE PLANS, DETAILS, AND TECHNICAL SPECIFICATIONS, INCLUDING MATERIAL TESTING, SOIL DENSITY, SOIL ANALYSIS, CONCRETE TESTING SHALL BE PAID BY THE OWNER FOR THE FIRST TEST. ANY TESTS THAT FAIL SHALL BE REPERFORMED UNTIL MEETING PASSING REQUIREMENTS AT THE CONTRACTOR'S EXPENSE.

CONTRACTOR SHALL COORDINATE PROJECT CONSTRUCTION TESTING WITH THE COUNTY INSPECTOR. ALL FAILED TESTS SHALL BE PAID FOR BY THE CONTRACTOR.

TESTS FOR SUITABILITY OF MATERIALS, PROCTOR, ETC. WILL BE PAID BY THE CONTRACTOR.

CONTRACTOR SHALL NOTIFY TESTING LAB TWENTY-FOUR (24) HOURS PRIOR TO BACKFILL OF ANY UTILITY TRENCH TO SCHEDULE FOR DENSITY TEST REQUIRED.

**TRAFFIC NOTES**

WHILE WORKING IN ROADWAYS, CONTRACTORS SHALL BACKFILL TRENCH AS WORK COMPLETED. SEE TRAFFIC CONTROL PLANS FOR TRAFFIC HANDLING AND FLAGGING OPERATIONS. ROADWAYS SHALL BE RESTORED TO NORMAL SERVICE AT THE END OF THE DAY.

IT IS THE CONTRACTOR'S RESPONSIBILITY TO SEE THAT ALL SIGNS AND BARRICADES ARE PROPERLY INSTALLED AND MAINTAINED. ALL LOCATIONS AND DISTANCES WILL BE DECIDED UPON IN THE FIELD BY THE CONTRACTOR, USING THE "TEXAS MANUAL ON UNIFORM TRAFFIC CONTROL DEVICES". THE COUNTY'S CONSTRUCTION INSPECTOR AND ENGINEERING REPRESENTATIVE WILL ONLY BE RESPONSIBLE TO INSPECT THE BARRICADES AND SIGNS. IF, IN THE OPINION OF THE ENGINEERING REPRESENTATIVE AND THE CONSTRUCTION INSPECTOR, THE BARRICADES SIGNS DO NOT CONFORM TO ESTABLISHED STANDARDS OR ARE INCORRECTLY PLACED OR ARE INSUFFICIENT IN QUANTITY TO PROTECT THE GENERAL PUBLIC, THE CONSTRUCTION INSPECTOR SHALL HAVE THE OPTION TO STOP OPERATIONS UNTIL SUCH TIME AS CONDITIONS ARE CORRECTED.

IF THE NEEDED ARISES, ADDITIONAL BARRICADES AND DIRECTIONAL DEVICES MAY BE ORDERED BY THE ENGINEERING REPRESENTATIVE AT THE CONTRACTOR'S EXPENSE.

ANY METHODS, STREET MARKINGS AND SIGNAGE NECESSARY FOR WARNING PEDESTRIANS OF DIVERTING TRAFFIC CONSTRUCTION SHALL CONFORM TO THE TEXAS MANUAL OF UNIFORM TRAFFIC CONTROL DEVICES FOR STREETS AND HIGHWAYS, LATEST EDITIONS.

PAVEMENT MARKINGS TO BE IN ACCORDANCE TO ITEM 666 OF TEXAS STANDARD SPECIFICATION PROVIDE CONSTRUCTION FENCING AND PEDESTRIAN TRAFFIC CONTROL WHERE APPLICABLE.

**ENVIRONMENTAL NOTES**

ALL SITE WORK MUST COMPLY WITH ENVIRONMENTAL REQUIREMENTS.

ALL AREAS DISTURBED OR EXPOSED DURING CONSTRUCTION SHALL BE REVEGETATED IN ACCORDANCE WITH PLANS SPECIFICATIONS. REVEGETATION OF ALL DISTURBED OR EXPOSED AREAS SHALL CONSIST OF SODDING OR THE TYPE OF REVEGETATION MUST EQUAL OR EXCEED THE TYPE OF VEGETATION PRESENT BEFORE CONSTRUCTION. ALL VEGETATION OUTSIDE THE CONSTRUCTION AREA SHALL REMAIN AS IS. ANY VEGETATION DISTURBED BY THE CONTRACTOR SHALL BE REPLACES AT THE CONTRACTOR'S EXPENSE.

THE CONTRACTOR SHALL MAINTAIN ALL ADJOINING ROADS, DRIVEWAYS AND TRAVELED ROUTES FREE FROM SPILLED AND OR TRACKED CONSTRUCTION MATERIALS AND OR DEBRIS. ALL MUD, DIRT, ROCKS DEBRIS, ETC., SPILLED, TRACKED OR OTHERWISE DEPOSITED ON EXISTING PAVED ROADS, DRIVES AND AREAS USED BY THE PUBLIC SHALL BE CLEANED UP IMMEDIATELY.

THE CONTRACTOR SHALL PROTECT ALL AREAS OF THE RIGHT OF WAY WHICH ARE NOT INCLUDED IN THE ACTUAL LIMITS OF THE PROPOSE CONSTRUCTION AREAS FROM DAMAGE. CARE SHALL BE EXERCISED TO PREVENT DAMAGE TO TREES, VEGETATION AND OTHER NATURAL SURROUNDINGS. THE CONTRACTOR AT HIS EXPENSE, SHALL RESTORE TO ANY AREAS DISTURBED AS A RESULT OF HIS OPERATIONS TO A CONDITION AS GOOD AS, OR BETTER THAN, THAT PRESENT PRIOR TO HIS CONTRACT. EXISTING ROAD SIGNS SHALL BE RESET AS REQUIRED. NO SEPARATE PAYMENT.

WEBB COUNTY ENGINEERING			
PUEBLO NUEVO PAVING PROJECT			
GENERAL NOTES			
PAGE	7	OF	

STRICT ADHERENCE TO DUST CONTROL WILL BE REQUIRED IN ALL AREAS, WHICH MAY REQUIRE PERIODIC MOISTURE TREATMENT OF THE SUBGRADE BY THE CONTRACTOR. THERE WILL BE NO SEPARATE PAY ITEM FOR SUCH MEASURES, WHICH WILL BE CONSIDERED SUBSIDIARY TO VARIOUS BID ITEMS INVOLVED. CONTRACTOR TO PROTECT EXISTING DRAINAGE CHANNELS AND PREVENT SILT AND EXCESS CONCRETE FROM ENTERING DRAINAGE SYSTEM.

**GENERAL NOTES**

FOR SLOPES OR TRENCHES GREATER THAN FIVE FEET IN DEPTH "ALL CONSTRUCTION OPERATIONS SHALL BE ACCOMPLISHED IN ACCORDANCE WITH APPLICABLE REGULATIONS OF THE UNITED STATES OCCUPATIONAL SAFETY AND HEALTH ADMINISTRATION,"

NO DRIVEWAY OR ROAD SHALL BE CLOSED OVERNIGHT. CONTRACTORS SHALL REPAIR ALL ROAD CROSSINGS, DRIVEWAY AND DITCHES TO THEIR ORIGINAL CONDITION OR BETTER. ROAD CROSSINGS SHALL BE REPAIRED WITHIN 10 WORKING DAYS AFTER CROSSING IS MADE.

ALL MATERIALS, EQUIPMENT, STAGING AND TEMPORARY SPOILS STORAGE IS TO BE WITHIN THE LIMITS OF THE CONSTRUCTION SHOWN ON THE APPROVED PLANS. ANY AREAS OUTSIDE THE LIMITS OF THE CONSTRUCTION SHOWN PROPOSED FOR THESE ACTIVITIES MUST BE REVIEWED AND APPROVED (BY OWNER) PRIOR TO USED ARE TO BE MAINTAINED DURING CONSTRUCTION.

FUEL STORAGE IS NOT ALLOWED. THE CONTRACTOR SHALL ADVISE OWNER IMMEDIATELY WITH WRITTEN DOCUMENTATION, OF ANY SPILLING OR FUEL OR TOXIC MATERIAL, INCLUDING ACTIONS TO CONTAIN CLEAN UP. CONTRACTOR IS RESPONSIBLE FOR DEWATERING OF WORK AREA. CONTRACTORS MUST SECURE WEBB COUNTY APPROVAL OF PROPOSED DEWATERING PROCEDURES PRIOR TO INSTALLATION OR USE, AND SHALL PROVIDE AND MAINTAIN ADEQUATE EQUIPMENT TO REMOVE AND DISPOSE OF ALL SURFACE AND GROUND WATERING ENTERING EXCAVATIONS, TRENCHES, OR THEIR PARTS OF THE WORK.

ALL WASTE MATERIAL EXCEPT FOR EXCESS SOIL SHALL BECOME PROPERTY OF THE CONTRACTOR AND SHALL BE HIS SOLE RESPONSIBILITY TO DISPOSE OF THIS MATERIAL OFF THE LIMITS OF THE PROJECT. NO WASTE MATERIAL SHALL BE PLACED IN EXISTING LOWS THAT WILL BLOCK OR ALTER FLOW LIMIT OF EXISTING ARTIFICIAL OR NATURAL DRAINAGE.

NO EXTRA PAYMENT SHALL BE ALLOWED FOR WORK CALLED FOR IN THE PLANS, BUT NOT INCLUDED IN THE BID PROPOSAL. THIS INCIDENTAL WORK WILL BE REQUIRED AND SHALL BE INCLUDED IN THE PAY ITEM TO WHICH IT RELATES. ALL BID ITEMS WILL BE PAID WHEN COMPLETED IN PLACE, TESTED AND ACCEPTED.

ALL CONSTRUCTION SHALL BE IN COMPLIANCE TO WEBB COUNTY CODES AND ORDINANCES FOR STANDARD CONSTRUCTION OR LATEST EDITION.

THE CONTRACTOR SHALL KEEP ACCURATE RECORDS OF ALL CONSTRUCTION THAT DEVIATES FROM THE FROM THE PLANS AND PROVIDE ENGINEERS WITH RED LINED SET OF AS BUILT DRAWINGS SHALL MEET THE SATISFACTION OF THE ENGINEERING DEPARTMENT PRIOR TO FINAL ACCEPTANCE.

WHERE REQUIRED BY FIXED FEATURES OR UNUSUAL CONDITIONS, THE SLOPES INDICATED HERE ON MAY BE VARIED WHEN SPECIFICALLY DIRECTED BY THE ENGINEER.

QUANTITIES SHOWN HEREON ARE PROVIDED FOR THE CONVENIENCE AND BENEFIT OF THE CONTRACTOR AND OTHER INTERESTED PARTIES. THE ENGINEER ASSUMES NO LIABILITY FOR THE ACCURACY AND COMPLETENESS OF SAID QUANTITIES. IT IS THE RESPONSIBILITY OF THE CONTRACTOR TO CHECK PLANS AND SPECIFICATION IN DETAIL IN THE PREPARATIONS OF BIDS.

CONTRACTOR SHALL PRESERVE THE CONSTRUCTION STAKES, MARKS, ETC., IF ANY ARE DESTROYED OR REMOVED BY THE CONTRACTOR OR HIS EMPLOYEES, THEY SHALL BE REPLACED AT THE CONTRACTOR'S EXPENSE. PROVIDE SUBMITTALS FOR ALL MATERIALS PROPOSED FOR PROJECT COMPLETION. CONTRACTOR SHALL MAINTAIN SERVICE TO EXISTING UTILITIES AT ALL TIMES DURING CONSTRUCTION. ALL MATERIALS AND CONSTRUCTION PROCEDURES WITHIN THE SCOPE OF THIS CONTRACT WERE NOT SPECIFICALLY COVERED ON THESE PLANS, SHALL CONFORM TO ALL APPLICABLE STANDARDS, TECHNICAL SPECIFICATION MANUAL AND THE TEXAS DEPARTMENT OF TRANSPORTATION STANDARD SPECIFICATIONS (LATEST EDITION) APPROVAL CRITERIA FOR FLEXIBLE BASE SOURCES AND APPROVAL OF AN AREA AND OR DEPTH OF LAYER IN SOURCE FROM WHICH MATERIAL IS TO BE SECURED, WILL BE ON PRELIMINARY TESTS AND SUCH OTHER OCCASIONAL TEST AS FOUND NECESSARY BY THE ENGINEER.

ALL BID ITEMS WILL BE PAID WHEN COMPLETED IN PLACE, TESTED AND ACCEPTED.

ALL DIRT WORK IS MADE PAYABLE AS COMPACTED MEASURE. CONTRACTOR IS RESPONSIBLE TO ESTABLISHED REQUIRED FILL BY APPLYING AN EXPANSION FACTOR.

PROSPECTIVE CONTRACTORS SHOULD FAMILIARIZE THEMSELVES WITH THE CONDITIONS AT THE SITE AND RETAIN THEIR OWN EXPERTS TO INTERPRET THE DATA IN THESE PLANS AND PERFORM ADDITIONAL TESTING AND OR INSPECTION AS THEY DEEM NECESSARY PRIOR TO BIDDING.

**UTILITY NOTES**

THE EXISTENCE AND LOCATION OF UNDERGROUND UTILITIES INDICATED IN THESE PLANS ARE TAKEN FROM AVAILABLE RECORDS THAT ARE NOT GUARANTEED, BUT SHALL BE INVESTIGATED AND VERIFIED BY THE CONTRACTOR BEFORE STARTING WORK. THE CONTRACTOR SHALL BE HELD RESPONSIBLE FOR ANY DAMAGE TO AND FOR THE MAINTENANCE AND PROTECTION OF THE EXISTING UTILITIES EVEN IF THEY ARE NOT SHOWN ON THE PLANS. LOCATION AND DEPTH OF THE EXISTING UTILITIES SHOWN HERE ARE APPROXIMATE ONLY. ACTUAL LOCATIONS AND DEPTH MUST BE VERIFIED BY THE CONTRACTOR PRIOR TO THE CONSTRUCTION AND SHALL BE RESPONSIBLE FOR PROTECTION OF THE SAME DURING CONSTRUCTION. IF ANY, THE CONTRACTOR SHALL CONTACT TEXAS ONE CALL 48 HOURS PRIOR TO CONSTRUCTION.

ANY DAMAGE OR EVIDENCE OF POSSIBLE DAMAGE TO EXISTING UTILITIES SHALL BE REPORTED TO THE INSPECTOR/ OWNER AND AFFECTED UTILITY IMMEDIATELY AND BEFORE BACKFILLING.

IF ANY OVERHEAD OR UNDERGROUND ELECTRICAL LINES NEED TO BE DE-ENERGIZED, THE CONTRACTOR SHALL CALL THE POWER COMPANY TO DO THE WORK. ALL COST ASSOCIATED TO THIS WILL BE AT THE CONTRACTOR'S EXPENSE

CONTRACTOR IS RESPONSIBLE FOR VERIFYING AND LOCATING ALL EXISTING UTILITY LINES AND COORDINATING RELOCATION AND REMOVAL WITH EACH UTILITY COMPANY. CONTRACTOR SHALL BE FULLY RESPONSIBLE FOR ANY AND ALL DAMAGES CAUSED BY FAILURE TO LOCATE AND PRESERVE UNDERGROUND UTILITIES.

WEBB COUNTY ENGINEERING			
PUEBLO NUEVO PAVING PROJECT			
GENERAL NOTES			
PAGE	8	OF	

COORDINATE WITH ELECTRICAL COMPANY POLE BRACING FOR CONSTRUCTION AROUND EXISTING POWER POLES. NO SEPARATE PAYMENT.

CONTRACTOR SHALL NOTIFY ALL UTILITY COMPANIES PRIOR TO CONSTRUCTION WITHIN CITY & TX DOT RIGHT OF WAY OR RECORDED EASEMENTS TO DETERMINE THE LOCATION OF EXISTING UTILITIES. CONTRACTOR SHALL NOTIFY THE UTILITY COMPANIES ON THE LIST PROVIDED AT LEAST 48 HOURS (48) HOURS PRIOR TO EXCAVATION OPERATION.

**GRADING NOTES**

EARTHWORK ON THE PROJECT SHOULD BE OBSERVED AND EVALUATED BY A TESTING LAB. THE EVALUATION OF THE EARTHWORK SHOULD INCLUDE OBSERVATION AND TESTING OF ENGINEERED FILL, SUBGRADE PREPARATION, AND OTHER GEOTECHNICAL CONDITIONS EXPOSED DURING THE CONSTRUCTION OF THE PROJECT.

IF THE SUBGRADE CANNOT BE ADEQUATELY COMPACTED TO MINIMUM DENSITIES DUE TO WET CONDITIONS AS DESCRIBED IN THE PLANS, CONTRACTOR TO ALLOW SUBGRADE TO DRY BY NATURAL MEANS IF THE SCHEDULE ALLOWS.

PRIOR TO PLACING ANY FILL, ANY VEGETATION, LOOSE TOPSOIL, AND ANY OTHER WISE UNSUITABLE MATERIALS SHOULD BE REMOVED FROM THE PROPOSED ROAD ALIGNMENT. THE STRIPPED MATERIALS CONSISTING OF VEGETATION AND ORGANIC MATERIALS SHOULD BE REMOVED FROM THE SITE, OR USED TO REVEGETATE LANDSCAPED AREAS OR EXPOSED SLOPES AFTER COMPLETION OF GRADING OPERATIONS

AFTER STRIPPING AND GRUBBING, THE SUBGRADE SHOULD BE PROOF ROLLED WHERE POSSIBLE TO AID IN LOCATING LOOSE OR SOFT AREAS.

POSITIVE DRAINAGE SHOULD BE PROVIDED DURING CONSTRUCTION TO PREVENT WATER FROM PONDING. INFILTRATION OF WATER INTO UTILITY TRENCHES SHOULD BE PREVENTED DURING CONSTRUCTIONS.

PRIOR TO ANY FILLING OPERATIONS, SAMPLES OF THE PROPOSED BORROW AND ONSITE MATERIALS SHOULD BE OBTAINED FOR LABORATORY MOISTURE DENSITY TESTING. THE TEST WILL PROVIDE A BASIS FOR EVALUATION OF FILL COMPACTION BY IN PLACE DENSITY TESTS. A QUALIFIED SOIL TECHNICIAN SHOULD PERFORM SUFFICIENT IN PLACE DENSITY TESTS DURING THE FILLING OPERATIONS TO EVALUATE THAT PROPER LEVELS OF COMPACTION, INCLUDING DRY UNIT WEIGHT AND MOISTURE CONTENT, ARE BEING ATTAINED.

ALL FILL SHOULD BE PLACED IN THIN, LOOSE LIFTS NOT TO EXCEED 6" WITHIN STREET SECTION AND 8" ELSEWHERE AND COMPACTED TO AT LEAST 95% OF THE MATERIAL'S STANDARD PROCTOR MAXIMUM DRY DENSITY (TEX-114-E). THE MATERIALS SHOULD BE MOISTURE CONDITIONED BETWEEN -2 AND +2 PERCENTAGE POINTS OF THE OPTIMUM MOISTURE CONTENT.

COMPACTION OF GRANULAR BASE COURSE SHOULD BE PLACED IN LOOSE LIFTS NOT TO EXCEED 8" AND COMPACTED TO AT LEAST 95% OF THE MAXIMUM DRY DENSITY AS DETERMINED BY THE MODIFIED MOISTURE DENSITY RELATION (TEX-113-E). THE MATERIALS SHOULD BE MOISTURE CONDITIONED BETWEEN -2 AND +2 PERCENTAGE POINTS OF THE OPTIMUM MOISTURE CONTENT.

WEBB COUNTY ENGINEERING			
PUEBLO NUEVO PAVING PROJECT			
GENERAL NOTES			
PAGE	9	OF	

EXISTING DIRT ROAD TO REMAIN IN PLACE UNTIL  
NEW CONSTRUCTION IS COMPLETE ON OTHER SIDE.

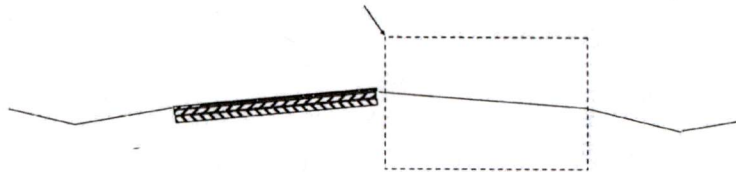

PHASE 1

EXISTING DIRT ROAD TO BE OBLITERATED. NEW CONSTRUCTION IS THEN COMPLETED ON THE REMAINING SIDE.



PHASE 2

## SEQUENCE OF WORK FOR EACH STREET



*Guillermo B. Cuellar, P.E.*  
2/2/2023

WEBB COUNTY ENGINEERING			
PUEBLO NUEVO PAVING PROJECT			
SEQUENCE OF WORK			
PAGE	10	OF	



EXISTING DIRT ROAD TO REMAIN IN PLACE UNTIL NEW CONSTRUCTION IS COMPLETE ON OTHER SIDE.  
 TRAFFIC TO REMAIN IN PLACE ON EXISTING SIDE UNTIL NEW SECTION IS COMPLETE. ONCE ONE SIDE IS COMPLETE,  
 TRAFFIC WILL BE SWITCHED TO OTHER SIDE SO THAT CONSTRUCTION CAN BEGIN ON OPPOSITE SIDE OF ROAD-  
 WAY.

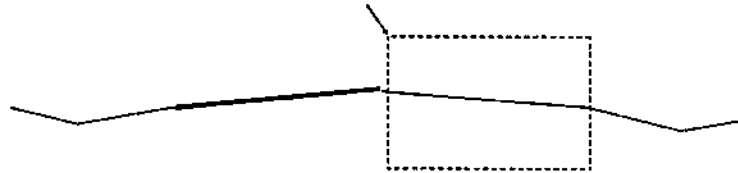

PHASE 1

EXISTING DIRT ROAD TO BE OBLITERATED. NEW CONSTRUCTION IS THEN COMPLETED ON THE REMAIN-  
 ING SIDE. ONCE COMPLETE IT WILL BE OPEN TO TROUGH TRAFFIC.

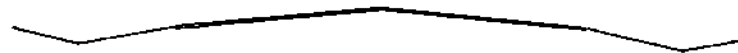

PHASE 2

TCP PLAN



*Guillermo B. Cuellar, P.E.*  
 2/2/2025

WEBB COUNTY ENGINEERING	
PUEBLO NUEVO PAVING PROJECT	
TRAFFIC CONTROL PLAN	
PAGE 11	OF 11

**COUNTY OF WEBB**

TEXAS COMMUNITY DEVELOPMENT PROGRAM CDV21-0485

PUEBLO NUEVO STREET IMPROVEMENT PROJECT

TxCDBG CDV21-0485

**HONORABLE TANO E. TIJERINA, WEBB COUNTY JUDGE**

**JESSE GONZALEZ**

COMMISSIONER, PRECINCT 1

**JOHN GALO**

COMMISSIONER, PRECINCT 3

**ROSAURA "WAWI" TIJERINA**

COMMISSIONER, PRECINCT 2

**RICARDO JAIME**

COMMISSIONER, PRECINCT 4

*This project is funded by the Texas Department of Agriculture with funds allocated by the U.S. Department of Housing and Urban Development through the Community Development Block Grant Program.*

**GENERAL NOTES:**

**PLACEMENT IN A PROMINENT VISIBLE PUBLIC AREA  
THAT IS NOT BLOCKED OR OBSCURED;**

**LETTERING NOT SMALLER THAN ONE-HALF INCH**

**3 FT HEIGHT BY 8 FT WIDTH**

WEBB COUNTY ENGINEERING			
PUEBLO NUEVO PAVING PROJECT			
TRAFFIC CONTROL PLAN			
PAGE	11A	OF	



**BARRICADE AND CONSTRUCTION (BC) STANDARD SHEETS GENERAL NOTES:**

1. The Barricade and Construction Standard Sheets (BC sheets) are intended to show typical examples for placement of temporary traffic control devices, construction pavement markings, and typical work zone signs. The information contained in these sheets meet or exceed the requirements shown in the "Texas Manual on Uniform Traffic Control Devices" (TMUTCD).
2. The development and design of the Traffic Control Plan (TCP) is the responsibility of the Engineer.
3. The Contractor may propose changes to the TCP that are signed and sealed by a licensed professional engineer for approval. The Engineer may develop, sign and seal Contractor proposed changes.
4. The Contractor is responsible for installing and maintaining the traffic control devices as shown in the plans. The Contractor may not move or change the approximate location of any device without the approval of the Engineer.
5. Geometric design of lane shifts and detours should, when possible, meet the applicable design criteria contained in manuals such as the American Association of State Highway and Transportation Officials (AASHTO), "A Policy on Geometric Design of Highways and Streets," the TxDOT "Roadway Design Manual" or engineering judgment.
6. When projects abut, the Engineer(s) may omit the END ROAD WORK, TRAFFIC FINES DOUBLE, and other advance warning signs if the signing would be redundant and the work areas appear continuous to the motorists. If the adjacent project is completed first, the Contractor shall erect the necessary warning signs as shown on these sheets, the TCP sheets or as directed by the Engineer. The BEGIN ROAD WORK NEXT X MILES sign shall be revised to show appropriate work zone distance.
7. The Engineer may require duplicate warning signs on the median side of divided highways where median width will permit and traffic volumes justify the signing.
8. All signs shall be constructed in accordance with the details found in the "Standard Highway Sign Designs for Texas," latest edition. Sign details not shown in this manual shall be shown in the plans or the Engineer shall provide a detail to the Contractor before the sign is manufactured.
9. The temporary traffic control devices shown in the illustrations of the BC sheets are examples. As necessary, the Engineer will determine the most appropriate traffic control devices to be used.
10. Where highway construction or maintenance work is being undertaken, other than mobile operations as defined by the Texas Manual on Uniform Traffic Control Devices, CSJ limit signs are required. CSJ limit signs are shown on BC(2). The OBEY WARNING SIGNS STATE LAW sign, STAY ALERT TALK OR TEXT LATER and the WORK ZONE TRAFFIC FINES DOUBLE sign with plaque shall be erected in advance of the CSJ limits. The BEGIN ROAD WORK NEXT X MILES, CONTRACTOR and END ROAD WORK signs shall be erected at or near the CSJ limits. For mobile operations, CSJ limit signs are not required.
11. Traffic control devices should be in place only while work is actually in progress or a definite need exists.
12. The Engineer has the final decision on the location of all traffic control devices.
13. Inactive equipment and work vehicles, including workers' private vehicles must be parked away from travel lanes. They should be as close to the right-of-way line as possible, or located behind a barrier or guardrail, or as approved by the Engineer.

**WORKER SAFETY NOTES:**

1. Workers on foot who are exposed to traffic or to construction equipment within the right-of-way shall wear high-visibility safety apparel meeting the requirements of ISEA "American National Standard for High-Visibility Apparel," or equivalent revisions, and labeled as ANSI 107-2004 standard performance for Class 2 or 3 risk exposure. Class 3 garments should be considered for high traffic volume work areas or night time work.
2. Except in emergency situations, flagger stations shall be illuminated when flagging is used at night.

**COMPLIANT WORKZONE TRAFFIC CONTROL DEVICES**

1. Only pre-qualified products shall be used. The "Compliant Work Zone Traffic Control Devices List" (CWZTCD) describes pre-qualified products and their sources.
2. Work zone traffic control devices shall be compliant with the Manual for Assessing safety Hardware (MASH).

THE DOCUMENTS BELOW CAN BE FOUND ON-LINE AT <a href="http://www.txdot.gov">http://www.txdot.gov</a>
COMPLIANT WORK ZONE TRAFFIC CONTROL DEVICES LIST (CWZTCD)
DEPARTMENTAL MATERIAL SPECIFICATIONS (DMS)
MATERIAL PRODUCER LIST (IMPL)
ROADWAY DESIGN MANUAL - SEE "MANUALS (ONLINE MANUALS)"
STANDARD HIGHWAY SIGN DESIGNS FOR TEXAS (SHSD)
TEXAS MANUAL ON UNIFORM TRAFFIC CONTROL DEVICES (TMUTCD)
TRAFFIC ENGINEERING STANDARD SHEETS

DISCLAIMER: The use of this standard is governed by the "Texas Engineering Practice Act," No. 900.001, of the Texas Constitution, which provides that the State Board of Professional Engineers, Architects, Surveyors and Geological Engineers shall have the authority to promulgate rules and regulations for the practice of the professions of engineering, architecture, surveying and geology.

DATE: \_\_\_\_\_  
 FILE: \_\_\_\_\_

SHEET 1 OF 12

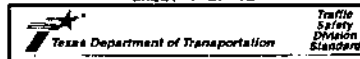

**BARRICADE AND CONSTRUCTION  
GENERAL NOTES  
AND REQUIREMENTS**

**BC(1)-21**

REV	DATE	BY	CHKD	APP'D
1	11-01-00	...	...	...
2	04-03-01	...	...	...
3	09-07-01	...	...	...
4	05-10-01	...	...	...



# TYPICAL APPLICATION OF WORK ZONE SPEED LIMIT SIGNS

Work zone speed limits shall be regulatory, established in accordance with the "Procedures for Establishing Speed Zones," and approved by the Texas Transportation Commission, or by City Ordinance when within Incorporated City Limits.

Reduced speeds should only be posted in the vicinity of work activity and not throughout the entire project. Regulatory work zone speed signs (R2-1) shall be removed or covered during periods when they are not needed.

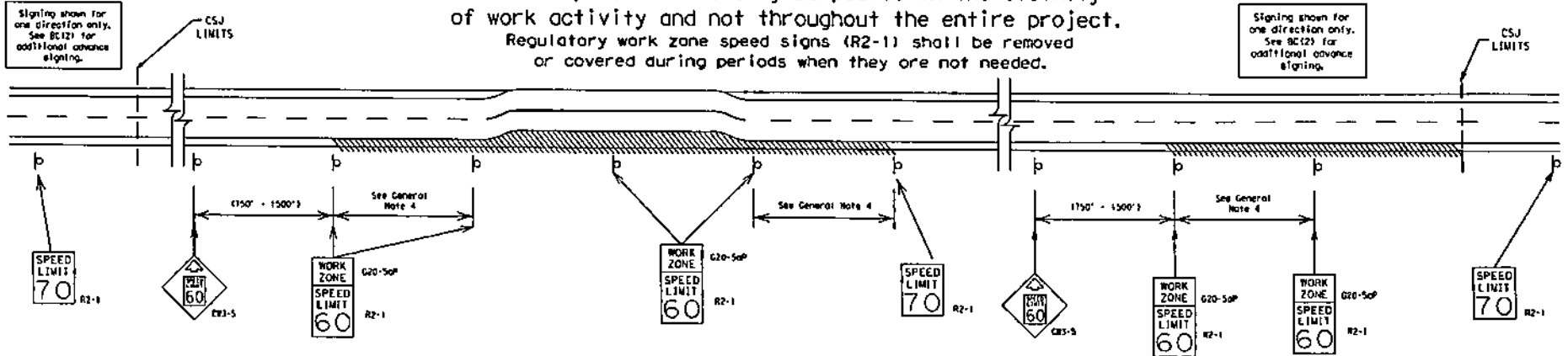

## GUIDANCE FOR USE:

### LONG/INTERMEDIATE TERM WORK ZONE SPEED LIMITS

This type of work zone speed limit should be included on the design of the traffic control plans when restricted geometrics with a lower design speed are present in the work zone and modification of the geometrics to a higher design speed is not feasible.

Long/Intermediate Term Work Zone Speed Limit signs, when approved as described above, should be posted and visible to the motorist when work activity is present.

Work activity may also be defined as a change in the roadway that requires a reduced speed for motorists to safely negotiate the work area, including:

- rough road or damaged pavement surface
- substantial alteration of roadway geometrics (diversions)
- construction detours
- grade
- width
- other conditions readily apparent to the driver

As long as any of these conditions exist, the work zone speed limit signs should remain in place.

### SHORT TERM WORK ZONE SPEED LIMITS

This type of work zone speed limit may be included on the design of the traffic control plans when workers or equipment are not behind concrete barrier, when work activity is within 10 feet of the traveled way or actually in the traveled way.

Short Term Work Zone Speed Limit signs should be posted and visible to the motorist only when work activity is present. When work activity is not present, signs shall be removed or covered. (See Removing or Covering on BC(4)).

### GENERAL NOTES

- Regulatory work zone speed limits should be used only for sections of construction projects where speed control is of major importance.
- Regulatory work zone speed limit signs shall be placed on supports at a 7 foot minimum mounting height.
- Speed zone signs are illustrated for one direction of travel and are normally posted for each direction of travel.
- Frequency of work zone speed limit signs should be:
  - 40 mph and greater 0.2 to 2 miles
  - 35 mph and less 0.2 to 1 mile
- Regulatory speed limit signs shall have black legend and border on a white reflective background (See "Reflective Sheeting" on BC(4)).
- Fabrication, erection and maintenance of the "ADVANCE SPEED LIMIT" (G20-50P) sign, "WORK ZONE" (G20-50P) plaque and the "SPEED LIMIT" (R2-1) signs shall not be paid for directly, but shall be considered subsidiary to Item 502.
- Turning signs from view, laying signs over or down will not be allowed, unless as otherwise noted under "REMOVING OR COVERING" on BC(4).
- Techniques that may help reduce traffic speeds include but are not limited to:
  - A. Law enforcement.
  - B. Flagger stationed next to sign.
  - C. Portable changeable message sign (PCMS).
  - D. Low-power (dome) radar transmitter.
  - E. Speed monitor trailers or signs.
- Speeds shown on details above are for illustration only. Work Zone Speed Limits should only be posted as approved for each project.
- For more specific guidance concerning the type of work, work zone conditions and factors impacting allowable regulatory construction speed zone reduction see TxDOT form #1204 in the TxDOT e-form system.

SHEET 3 OF 12

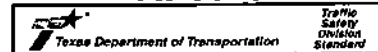

## BARRICADE AND CONSTRUCTION WORK ZONE SPEED LIMIT

BC(3)-21

DATE	BY	REVISION
9-07	8-14	
7-13	5-21	

DISCLAIMER: This document is prepared by the "Texas Engineering Practice Act". No warranty of any kind is made by TxDOT for any purpose whatsoever. TxDOT assumes no responsibility for the consequences of this document or any other documents or reports or for any errors or omissions resulting from its use.

DATE: FILE:



DISCLAIMER: The use of this standard is governed by the Texas Engineering Practice Act, which requires that the user of this standard be aware of the limitations of the standard and that the user of this standard be aware of the limitations of the standard.

**TYPICAL MINIMUM CLEARANCES FOR LONG TERM AND INTERMEDIATE TERM SIGNS**

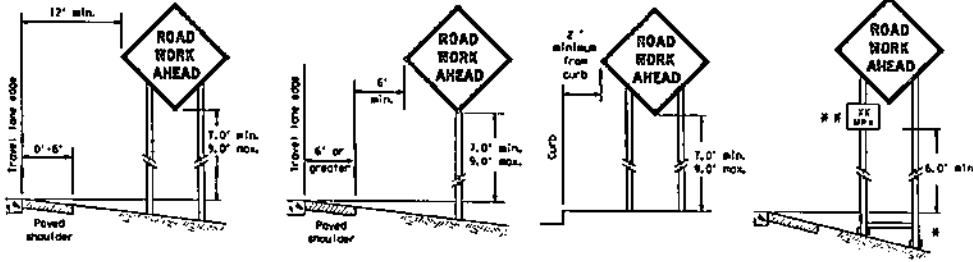

When placing skid supports on uneven ground, the leg post lengths must be adjusted so the sign appears straight and plumb. Objects shall NOT be placed under skids as a means of leveling.

When plaques are placed on dual-leg supports, they should be attached to the upright nearest the travel lane. Supplemental plaques (auxiliary or distance) should not cover the surface of the parent sign.

**ATTACHMENT FOR SIGN SUPPORTS**

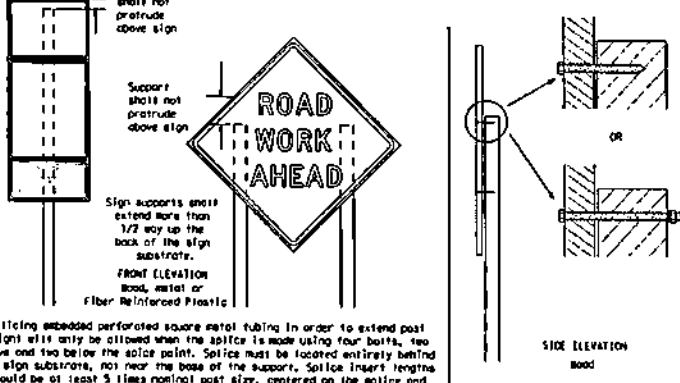

Splicing embedded perforated square metal tubing in order to extend post height will only be allowed when the splice is made using four bolts, two above and two below the splice point. Splice must be located entirely behind the sign substrate, not near the base of the support. Splice insert lengths should be at least 5 times nominal post size, centered on the splice and of at least the same gauge material.

**GENERAL NOTES FOR WORK ZONE SIGNS**

- Contractor shall install and maintain signs in a straight and plumb condition and/or as directed by the Engineer.
- Room sign posts shall be painted white.
- Workloads shall NOT be used as sign supports.
- All signs shall be installed in accordance with the plans or as directed by the Engineer. Signs shall be used to regulate, warn, and guide the traveling public safely through the work zone.
- The Contractor may furnish either the sign design shown in the plans or in the "Standard Highway Sign Design for Texas" (SHSD). The Engineer/Inspector may require the Contractor to furnish other work zone signs that are shown in the SHSD but may have been omitted from the plans. Any variation in the plans shall be documented by written agreement between the Engineer and the Contractor's Responsible Person. All changes must be documented in writing before being implemented. This can include documenting the changes in the Inspector's T-01 diary and having both the Inspector and Contractor initial and date the agreed upon changes.
- The Contractor shall furnish sign supports listed in the "Companion Work Zone Traffic Control Device List" (CWZCD) for small roadside signs. Supports for temporary large roadside signs shall meet the requirements detailed on the Temporary Large Roadside Signs (TLRS) standard sheets. The Contractor shall install the sign support in accordance with the manufacturer's recommendations. If there is a question regarding installation procedures, the Contractor shall furnish the Engineer a copy of the manufacturer's installation recommendations so the Engineer can verify the correct procedures are being followed.
- The Contractor is responsible for installing signs on approved supports and replacing signs with damaged or cracked substrates and/or damaged or faded reflective sheeting as directed by the Engineer/Inspector.
- Identification markings may be shown only on the back of the sign substrate. The maximum height of letters and/or canopy logos used for identification shall be 1 inch.
- The Contractor shall replace damaged wood posts. New or damaged wood sign posts shall not be spliced.

**DURATION OF WORK (as defined by the "Texas Manual on Uniform Traffic Control Devices" Part 6)**

- The types of sign supports, sign mounting height, the size of signs, and the type of sign substrates can vary based on the type of work being performed. The Engineer is responsible for selecting the appropriate size sign for the type of work being performed. The Contractor is responsible for ensuring the sign support, sign mounting height and substrate meets manufacturer's recommendations. In regard to construction and duration of work requirements:
  - Long-term stationary - work that occupies a location more than 1 day.
  - Intermediate-term stationary - work that occupies a location more than one daylight period up to 3 days, or nighttime work lasting more than one hour.
  - Short-term stationary - daytime work that occupies a location for more than 1 hour in a single daylight period.
  - Short duration - work that occupies a location up to 1 hour.
  - Mobile - work that moves continuously or intermittently (stopping for up to approximately 15 minutes.)

**SIGN MOUNTING HEIGHT**

- The bottom of long-term/intermediate-term signs shall be at least 1 foot, but not more than 9 feet, above the paved surface, except as shown for supplemental plaques mounted below other signs.
- The bottom of short-term/short duration signs shall be a minimum of 1 foot above the paved surface but no more than 2 feet above the ground.
- Long-term/intermediate-term signs may be used in lieu of short-term/short duration signs.
- Short-term/short duration signs shall be used only during daylight and shall be removed at the end of the workday or raised to appropriate long-term/intermediate sign height.
- Regulatory signs shall be mounted at least 7 feet, but not more than 9 feet, above the paved surface regardless of work duration.

**SIZE OF SIGNS**

- The Contractor shall furnish the sign sizes shown on BC (2) unless otherwise shown in the plans or as directed by the Engineer.

**SIGN SUBSTRATES**

- The Contractor shall ensure the sign substrate is installed in accordance with the manufacturer's recommendations for the type of sign support that is being used. The CWZCD lists each substrate that can be used on the different types and models of sign supports.
- "Mesh" type materials are NOT on approved sign substrate, regardless of the tightness of the weave.
- All approved individual sign panels fabricated from 2 or more panels shall have one or more plywood, 1/2" thick by 6" wide, fastened to the back of the sign and extending fully across the sign. The plywood shall be attached to the back of the sign using wood screws that do not penetrate the face of the sign panel. The screws shall be placed on both sides of the splice and spaced at 6" centers. The Engineer may approve other methods of splicing the sign face.

**REFLECTIVE SHEETING**

- All signs shall be retro-reflective and constructed of sheeting meeting the color and retro-reflectivity requirements of DMS-8300 for rigid signs or DMS-8310 for roll-up signs. The web address for DMS specification is shown on BC(1).
- White sheeting, meeting the requirements of DMS-8300 Type A, shall be used for signs with a white background.
- Orange sheeting, meeting the requirements of DMS-8300 Type B<sub>1</sub> or Type C<sub>1</sub>, shall be used for rigid signs with orange backgrounds.

**SIGN LETTERS**

- All sign letters and numbers shall be clear, and open rounded type uppercase alphabet letters as observed by the Federal Highway Administration (FHWA) and as published in the "Standard Highway Sign Design for Texas" manual. Signs, letters and numbers shall be of first class workmanship in accordance with Department Standards and Specifications.

**REMOVING OR COVERING**

- When sign messages may be confusing or do not apply, the signs shall be removed or completely covered.
- Long-term stationary or intermediate stationary signs installed on square metal tubing may be turned away from traffic 90 degrees when the sign message is not applicable. This technique may not be used for signs installed in the median of divided highways or near any intersections where the sign may be seen from approaching traffic.
- Signs installed on wooden posts shall not be turned 90 degree angles to the roadway. These signs should be removed or completely covered when not required.
- When signs are covered, the material used shall be opaque, such as heavy mil black plastic, or other materials which will cover the entire sign face and maintain their opaque properties under automobile headlights at night, without damaging the sign sheeting.
- Burial shall NOT be used to cover signs.
- Dead tape or other adhesive material shall NOT be affixed to a sign face.
- Signs and anchor studs shall be removed and holes backfilled upon completion of work.

**SIGN SUPPORT HEIGHTS**

- Where sign supports require the use of weights to keep from turning over, the use of sandbags with dry, cementitious sand should be used.
- The sandbags will be tied shut to keep the sand from spilling and to maintain a constant weight.
- Rock, concrete, brick, steel or other solid objects shall not be permitted for use as sign support weights.
- Sandbags shall weigh a minimum of 35 lbs and a maximum of 50 lbs.
- Sandbags shall be made of a durable material that tears upon vehicular impact. Rubber (such as fire liner) shall NOT be used.
- Rubber ballistics designed for channelizing devices should not be used for ballast on portable sign supports. Sign supports designed and manufactured with rubber bases may be used when shown on the CWZCD list.
- Sandbags shall only be placed along or laid over the base supports of the traffic control device and shall not be suspended above ground level or hung with rope, wire, chains or other fasteners. Sandbags shall be placed along the length of the skids to weigh down the sign support.
- Sandbags shall NOT be placed under the skid and shall not be used to level sign supports placed on slopes.

**FLAGS ON SIGNS**

- Flags may be used to draw attention to warning signs. When used, the flag shall be 6 inches wide or larger and shall be orange or fluorescent red-orange in color. Flags shall not be allowed to cover any portion of the sign face.

**STOP/SLOW PADDLES**

- STOP/SLOW paddles are the primary method to control traffic by flaggers. The STOP/SLOW paddle size should be 24" x 24".
- STOP/SLOW paddles shall be retro-reflective when used at night.
- STOP/SLOW paddles may be attached to a staff with a minimum length of 6" to the bottom of the sign.
- Any lights incorporated into the STOP or SLOW paddle faces shall only be as specifically described in Section 6E.03 Road Signaling Devices in the MUTCD.

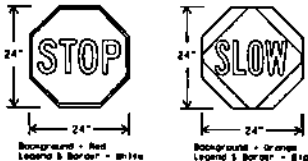

SHEETING REQUIREMENTS (WHEN USED AT NIGHT)		
USAGE	COLOR	SIGN FACE MATERIAL
BACKGROUND	RED	TYPE B OR C SHEETING
BACKGROUND	ORANGE	TYPE B <sub>1</sub> OR C <sub>1</sub> SHEETING
LEGEND & BORDER	WHITE	TYPE B OR C SHEETING
LEGEND & BORDER	BLACK	ACRYLIC NON-REFLECTIVE FILM

**CONTRACTOR REQUIREMENTS FOR MAINTAINING PERMANENT SIGNS WITHIN THE PROJECT LIMITS**

- Permanent signs are to give notice of traffic laws or regulations, call attention to conditions that are potentially hazardous to traffic operations, show route designations, destinations, directions, distances, services, points of interest, and other geographical, recreational, specific service (L000), cultural information. Drivers proceeding through a work zone need the same, if not better route guidance as normally installed on a roadway without construction.
- When permanent regulatory or warning signs conflict with work zone conditions, remove or cover the permanent signs until the permanent sign message matches the roadway condition. For details for covering large guide signs see the TS-CD standard.
- When existing permanent signs are moved or relocated due to construction purposes, they shall be visible to motorists as all times.
- If existing signs are to be relocated on their original supports, they shall be installed on crossworthy bases as shown on the S&D Standard sheets. The signs shall meet the required mounting heights shown on the BC Sheets or the S&D Standards. This work should be paid for under the appropriate pay item for relocating existing signs.
- If permanent signs are to be removed and relocated using temporary supports, the Contractor shall use crossworthy supports as shown on the BC standard sheets. The standard sheets or the CWZCD list. The signs shall meet the required mounting heights shown on the BC, or the S&D standard sheets during construction. This work should be paid for under the appropriate pay item for relocating existing signs.
- Any sign or traffic control device that is struck or damaged by the Contractor or his/her construction equipment shall be replaced as soon as possible by the Contractor to ensure proper advance for the motorists. This will be subsidiary to Item 502.

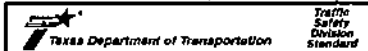

**BARRICADE AND CONSTRUCTION TEMPORARY SIGN NOTES**

BC (4) - 21

DATE	BY	REVISION
9-07	8-14	
1-15	5-21	

DISCLAIMER: The use of this standard is governed by the Texas Engineering Practice Act. No warranty of any kind is made by TCEQ for the use of this standard for any purpose other than that intended. TCEQ is not responsible for any consequences resulting from its use.

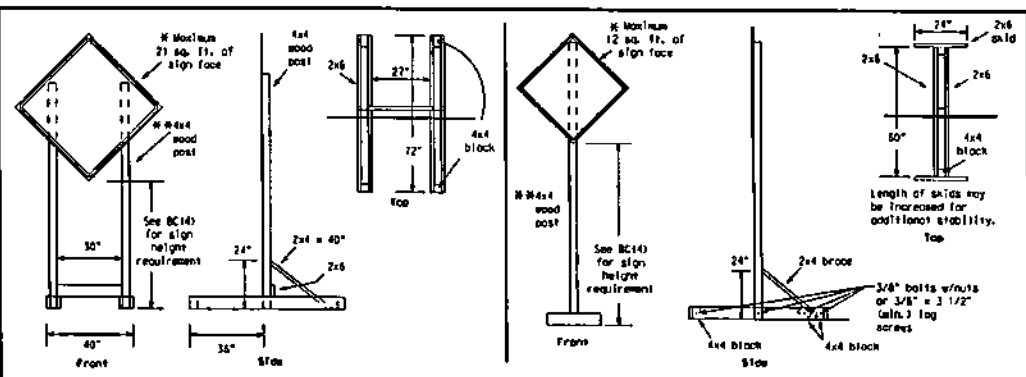

**SKID MOUNTED WOOD SIGN SUPPORTS**  
 \* LONG/INTERMEDIATE TERM STATIONARY - PORTABLE SKID MOUNTED SIGN SUPPORTS

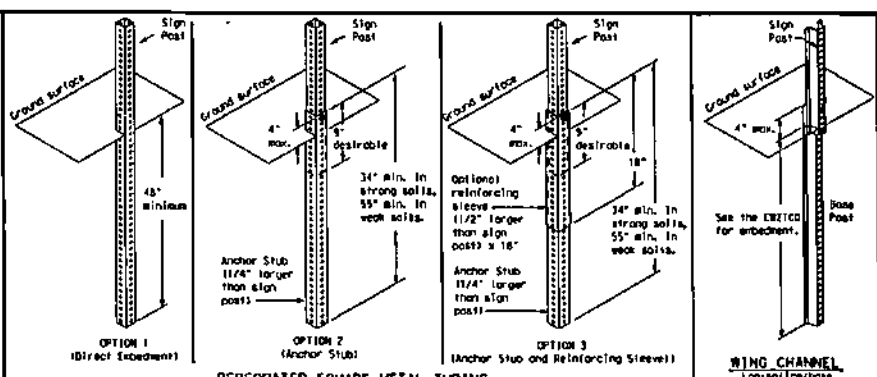

**PERFORATED SQUARE METAL TUBING**  
**GROUND MOUNTED SIGN SUPPORTS**

Refer to the CR210 and the manufacturer's installation procedure for each type sign support. The maximum sign square footage shall adhere to the manufacturer's recommendation. Two post installations can be used for larger signs.

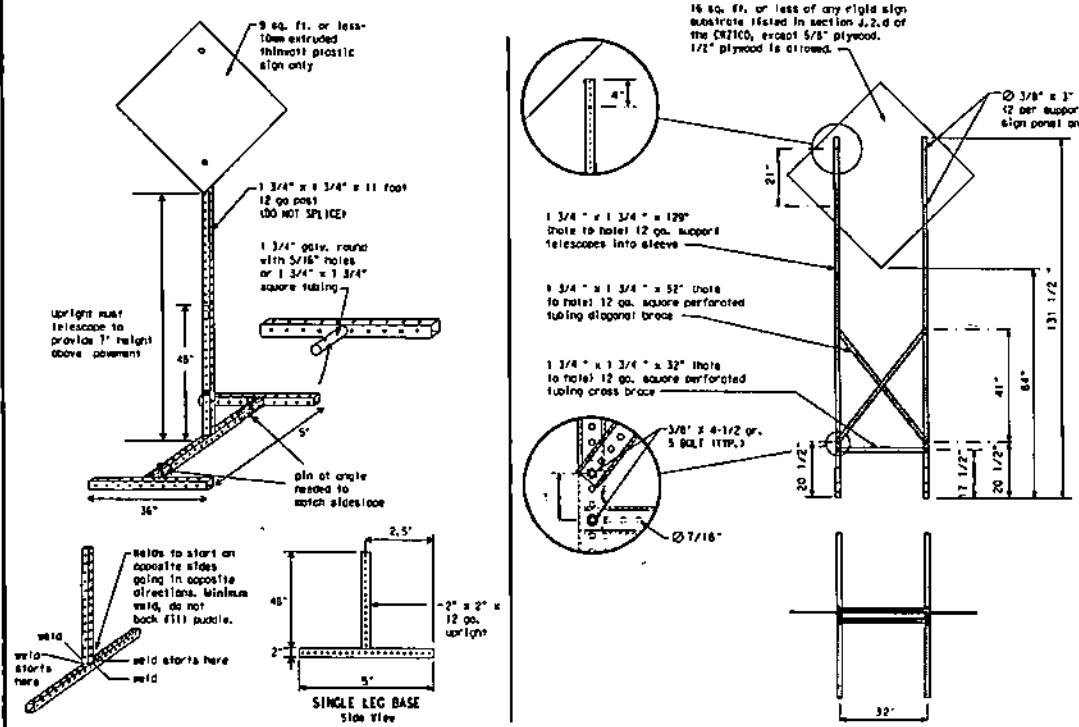

**SKID MOUNTED PERFORATED SQUARE STEEL TUBING SIGN SUPPORTS**  
 \* LONG/INTERMEDIATE TERM STATIONARY - PORTABLE SKID MOUNTED SIGN SUPPORTS

**WEDGE ANCHORS**  
 Both steel and plastic Wedge Anchor Systems as shown on the S40 Standard Sheets may be used on temporary sign supports for signs up to 10 square feet of sign face. They may be set in concrete or in sturdy soils if approved by the Engineer. (See web address for "Traffic Engineering Standard Sheets" on BC111).

**OTHER DESIGNS**  
 MORE DETAILS OF APPROVED LONG/INTERMEDIATE AND SHORT TERM SUPPORTS CAN BE FOUND ON THE CR210 LIST. SEE BC111 FOR WEBSITE LOCATION.

**GENERAL NOTES**

1. Bolts may be used in the assembly of wooden sign supports, but 3/8" bolts with nuts or 3/8" x 3 1/2" lag screws must be used on every joint for final connection.
2. No more than 2 sign posts shall be placed within a 7 ft. circle, except for specific materials noted on the CR210 list.
3. When project is completed, all sign supports and foundations shall be removed from the project site. This will be considered auxiliary to Item 502.

\* See BC14 for definition of "Work Duration."  
 \*\* Good sign posts MUST be one piece. Splicing will NOT be allowed. Posts shall be pointed white.  
 See the CR210 for the type of sign substrate that can be used for each approved sign support.

SHEET 5 OF 12  
 Texas Department of Transportation  
 Traffic Safety Division Standard

**BARRICADE AND CONSTRUCTION TYPICAL SIGN SUPPORT**

BC (5) - 21

DATE:	BY:	APP'D:	REV:
1-15-01	1-15-01	1-15-01	1-15-01
1-15-01	1-15-01	1-15-01	1-15-01

WHEN NOT IN USE, REMOVE THE PCMS FROM THE RIGHT-OF-WAY OR PLACE THE PCMS BEHIND BARRIER OR GUARDRAIL WITH SIGN PANEL TURNED PARALLEL TO TRAFFIC.

**PORTABLE CHANGEABLE MESSAGE SIGNS**

- The Engineer/Inspector shall approve all messages used on portable changeable message signs (PCMS).
- Messages on PCMS should contain no more than 8 words (about four to eight characters per word), not including alleys such as "TO," "FOR," "AT," etc.
- Messages should consist of a single phase, or two phases that alternate. (Two-phase messages are not allowed. Each phase of the message should convey a single thought, and must be understood by itself.)
- Use the word "EXIT" to refer to an exit ramp on a freeway, i.e., "EXIT CLOSED." Do not use the term "RAMP."
- Always use the route or Interstate designation (IR, US, SH, FM) along with the number when referring to a roadway.
- When in use, the bottom of a stationary PCMS message panel should be a minimum 7 feet above the roadway, where possible.
- The message term "AHEAD" should be used only if the work is to start on Saturday morning and end by Sunday evening at midnight. Actual days and hours of work should be displayed on the PCMS if work is to begin on Friday evening and/or continue into Monday morning.
- The Engineer/Inspector may select one of two options which are available for displaying a two-phase message on a PCMS. Each phase may be displayed for either four seconds each or for three seconds each.
- Do not "flash" messages or words included in a message. The message should be steady burn or continuous while displayed.
- Do not present redundant information on a two-phase message, i.e., keeping two lines of the message the same and changing the third line. Do not use the word "DANGER" in a message.
- Do not display the message "LANES SHIFT LEFT" or "LANES SHIFT RIGHT" on a PCMS. Drivers do not understand the message.
- Do not display messages that scroll horizontally or vertically across the face of the sign.
- The following table lists abbreviated words and two-word phrases that are acceptable for use on a PCMS. Both words in a phrase must be displayed together, words or phrases not on this list should not be abbreviated, unless shown in the table.
- PCMS character height should be at least 18 inches for trailer mounted units. They should be visible from at least 1/2 mile and the text should be legible from at least 400 feet at night and 800 feet in daylight. Truck mounted units must have a character height of 10 inches and must be legible from at least 400 feet.
- Each line of text should be centered on the message board rather than left or right justified.
- If displayed, the PCMS should default to an illegible display that will not alarm motorists and will only be used to alert workers that the PCMS has malfunctioned. A pattern such as a series of horizontal solid bars is appropriate.

**RECOMMENDED PHASES AND FORMATS FOR PCMS MESSAGES DURING ROADWORK ACTIVITIES**

(The Engineer may approve other messages not specifically covered here.)

**Phase 1: Condition Lists**

Road/Lane/Ramp Closure List		Other Condition List	
FREWAY CLOSED X MILE	FRONTAGE ROAD CLOSED	ROADWORK XXX FT	ROAD REPAIRS XXXX FT
ROAD CLOSED AT SH XXX	SHOULDER CLOSED XXX FT	FLACER XXXX FT	LANE NARROWES XXXX FT
ROAD CLSD AT FM XXXX	RIGHT LN CLOSED XXX FT	RIGHT LN NARROWES XXXX FT	TWO-WAY TRAFFIC XX MILE
RIGHT X LANES CLOSED	RIGHT X LANES OPEN	MERGING TRAFFIC XXXX FT	CONST TRAFFIC XXX FT
CENTER LANE CLOSED	DAYTIME LANE CLOSURES	LOOSE GRAVEL XXXX FT	UNEVEN LANES XXXX FT
NIGHT LANE CLOSURES	I-XX SOUTH EXIT CLOSED	DETOUR X MILE	ROUGH ROAD XXXX FT
VARIOUS LANES CLOSED	EXIT XXX CLOSED X MILE	ROADWORK PAST SH XXXX	ROADWORK NEXT FRI-SUN
EXIT CLOSED	RIGHT LN TO BE CLOSED	BUMP XXXX FT	US XXX EXIT X MILES
MALL DRIVEWAY CLOSED	X LANES CLOSED TUE - FRI	TRAFFIC SIGNAL XXXX FT	LANES SHIFT
XXXXXXXX BLVD CLOSED			

\* LANES SHIFT in Phase 1 must be used with STAY IN LANE in Phase 2.

**Phase 2: Possible Component Lists**

Action to Take/Effect on Travel List	Location List	Warning List	X Advance Notice List
MERGE RIGHT	AT FM XXXX	SPEED LIMIT XX MPH	TUE-FRI XX AM - X PM
DETOUR NEXT X EXIT	BEFORE RAILROAD CROSSING	MAXIMUM SPEED XX MPH	APR XX - XX X PM-X AM
USE EXIT XXX	NEXT X MILES	MINIMUM SPEED XX MPH	BEGINS MONDAY
STAY ON US XXX SOUTH	PAST US XXX EXIT	ADVISORY SPEED XX MPH	BEGINS MAY XX
TRUCKS USE US XXX N	XXXXXXXX TO XXXXXXX	RIGHT LANE EXIT	MAY X-X XX PM - XX AM
WATCH FOR TRUCKS	US XXX TO FM XXXX	USE CAUTION	NEXT FRI-SUN
EXPECT DELAYS		DRIVE SAFELY	XX AM TO XX PM
REDUCE SPEED XXX FT		DRIVE WITH CARE	NEXT TUE AHEAD XX
USE OTHER ROUTES			TONIGHT XX PM - XX AM
STAY IN LANE			

\*\* See Application Guidelines Note 6.

**APPLICATION GUIDELINES**

- Only 1 or 2 phases are to be used on a PCMS.
- The last phase for both should be selected from the "Road/Lane/Ramp Closure List" and the "Other Condition List".
- A 2nd phase can be selected from the "Action to Take/Effect on Travel, Location, General Warning, or Advance Notice Phase Lists".
- A Location Phase is necessary only if a distance or location is not included in the first phase selected.
- If two PCMS are used in sequence, they must be separated by a minimum of 1000 ft. Each PCMS must be limited to two phases, and should be understandable by themselves.
- For advance notice, when the current date is within seven days of the actual work date, calendar days should be replaced with days of the week. Advance notification should typically be for no more than one week prior to the work.

**WORDING ALTERNATIVES**

- The words RIGHT, LEFT and AHEAD can be interchanged as appropriate.
- Roadway designations IR, US, SH, FM and LP can be interchanged as appropriate.
- EAST, WEST, NORTH and SOUTH for abbreviations E, W, N and S can be interchanged as appropriate.
- Highway names and numbers replaced as appropriate.
- ROAD, HIGHWAY and FREEWAY can be interchanged as needed.
- AHEAD may be used instead of distances if necessary.
- FT and MI, MILE and MILES interchanged as appropriate.
- AT, BEFORE and PAST interchanged as needed.
- Distances or AHEAD can be eliminated from the message if a location phase is used.

PCMS SIGNS WITHIN THE R.O.W. SHALL BE BEHIND GUARDRAIL OR CONCRETE BARRIER OR SHALL HAVE A MINIMUM OF FOUR (4) PLASTIC DRUMS PLACED PERPENDICULAR TO TRAFFIC ON THE UPSTREAM SIDE OF THE PCMS. WHEN EXPOSED TO ONE DIRECTION OF TRAFFIC, WHEN EXPOSED TO TWO WAY TRAFFIC, THE FOUR DRUMS SHOULD BE PLACED WITH ONE DRUM AT EACH OF THE FOUR CORNERS OF THE UNIT.

**FULL MATRIX PCMS SIGNS**

- When Full Matrix PCMS signs are used, the character height and legibility/visibility requirements shall be maintained as listed in Note 15 under "PORTABLE CHANGEABLE MESSAGE SIGNS" above.
- When symbol signs, such as the "Trigger Symbol" (ICR20-7) are represented graphically on the Full Matrix PCMS sign and, with the approval of the Engineer, it shall maintain the legibility/visibility requirements listed above.
- When symbol signs are represented graphically on the Full Matrix PCMS, they shall only supplement the use of the static sign represented, and shall not substitute for, or replace that sign.
- A Full Matrix PCMS may be used to simulate a flashing arrow board provided it meets the visibility, flash rate and timing requirements on BC(7), for the same size arrow.

DISC NUMBER: \_\_\_\_\_  
 DATE: \_\_\_\_\_ FILE: \_\_\_\_\_  
 The use of this standard is governed by the Texas Engineering Practice Act. No warranty of any kind is made by TCEQ for any purpose whatsoever. TCEQ does not assume any liability or responsibility for this standard or for the use of this standard by other persons or for the consequences of its use.

WORD OR PHRASE	ABBREVIATION	WORD OR PHRASE	ABBREVIATION
Access Road	ACCESS RD	Water	WTR
Alternate	ALT	Miles	MI
Average	AVE	Miles Per Hour	MPH
Best Route	BEST RTE	Minor	MINR
Bolevard	BLVD	Monday	MON
Bridge	BRDG	Normal	NORM
Carrot	CART	North	N
Center	CTR	Northbound	TRAVEL N
Construction	CONST AHD	Parking	PKNG
Road	RD	Right	RT
CROSSING	XING	Right Lane	RT LN
Detour Route	DETOUR RTE	Saturday	SAT
Do Not	DN	Service Road	SERV RD
East	E	Shoulder	SHDR
Eastbound	TRAVEL E	Stripper	SLIP
Emergency	EMER	South	S
Emergency Vehicle	EMER VEH	Southbound	TRAVEL S
Entrance, Exit	ENT	Speed	SPD
Express Lane	EXP LN	Street	ST
Expressway	EXPWY	Sunday	SUN
Exit Lane	EXIT LN	Telephone	PHONE
Exit Ramp	EXIT RMP	Emergency	EMER
Flag Ahead	FLAG AHD	Thursday	THURS
Freeway	FRWAY	Friday	FRI
Freeway Blocked	FRWAY BLCKD	To Downtown	TO DOWNTN
Friday	FRI	Traffic	TRAF
Highway	HWY	Travelers	TRVLRS
Highway Driving	HWY DRIVING	Tuesday	TUE
Hazardous Material	HAZMAT	Two Minutes	TWO MIN
High Occupancy	HVOY	Upper Level	UPR LEVEL
Vehicle	VEH	Vehicles (pl)	VEH, VEHs
Highway	HWY	Warning	WARN
Hourly	HR, HRS	Wednesday	WED
Information	INFO	Weight Limit	WT LIMIT
It Is	IT IS	West	W
Junction	JCT	Westbound	TRAVEL W
Left	L	West Ramp	WEST RMP
Left Lane	LEFT LN	Will Not	WILL NOT
Lane Closed	LN CLOSED		
Lane Level	LN LEVEL		
Maintenance	MAINT		

Roadway designation: IIR-number, US-number, SH-number, FM-number

Texas Department of Transportation

**BARRICADE AND CONSTRUCTION PORTABLE CHANGEABLE MESSAGE SIGN (PCMS)**

**BC(6)-21**

9-07 8-14  
7-13 5-21



DISCLAIMER: The use of this standard is governed by the "Texas Department of Transportation Standard Specifications for Materials and Methods of Construction" and the "Texas Manual on Uniform Traffic Control Devices" (TMUDCD) and the "Companion Work Zone Traffic Control Devices List" (CWTCDL).

**GENERAL NOTES**

- For long term stationary work zones on freeways, drums shall be used as the primary channelizing device.
- For intermediate term stationary work zones on freeways, drums should be used as the primary channelizing device but may be replaced in tangent sections by vertical panels, or 42" two-piece cones. In tangent sections, one-piece cones may be used with the approval of the Engineer but only if personnel are present on the project at all times to maintain the cones in proper position and location.
- For short term stationary work zones on freeways, drums are the preferred channelizing device but may be replaced in tapers, transitions and tangent sections by vertical panels, two-piece cones or one-piece cones as approved by the Engineer.
- Drums and cone retroreflective items shall comply with the requirements of the current version of the "Texas Manual on Uniform Traffic Control Devices" (TMUDCD) and the "Companion Work Zone Traffic Control Devices List" (CWTCDL).
- Drums, bases, and related materials shall exhibit good workmanship and shall be free from objectionable marks or defects that would adversely affect their appearance or serviceability.
- The Contractor shall have a maximum of 24 hours to replace any plastic drum identified for replacement by the Engineer/Inspector. The replacement device must be an approved device.

**GENERAL DESIGN REQUIREMENTS**

Pre-qualified plastic drums shall meet the following requirements:

- Plastic drums shall be a two-piece design: the "body" of the drum shall be the top portion and the "base" shall be the bottom.
- The body and base shall lock together in such a manner that the body separates from the base when impacted by a vehicle traveling at a speed of 20 MPH or greater but prevents accidental separation due to normal handling and/or air turbulence created by passing vehicles.
- Plastic drums shall be constructed of lightweight flexible, and durable materials. The Contractor shall not use metal drums or single piece plastic drums as channelizing devices or sign supports.
- Drums shall present a profile that is a minimum of 18 inches in width at the 36 inch height when viewed from any direction. The height of drums until body installed on base shall be a minimum of 36 inches and a maximum of 42 inches.
- The top of the drum shall have a built-in handle for easy pickup and shall be designed to drain water and not collect debris. The handle shall have a minimum of two widely spaced 3/16 inch diameter holes to allow attachment of a warning light, warning reflector unit or approved compliant sign.
- The exterior of the drum body shall have a minimum of four alternating orange and white retroreflective circumferential stripes not less than 4 inches nor greater than 8 inches in width. Any non-reflective space between any two adjacent stripes shall not exceed 2 inches in width.
- Bases shall have a maximum width of 36 inches, a maximum height of 4 inches, and a minimum of two footings of sufficient size to allow base to be held down when separating the drum body from the base.
- Plastic drums shall be constructed of ultra-violet stabilized, orange, high-density polyethylene (HDPE) or other approved material.
- Drum body shall have a maximum unballasted weight of 11 lbs.
- Drum and base shall be marked with manufacturer's name and model number.

**RETROREFLECTIVE SHEETING**

- The stripes used on drums shall be constructed of sheeting meeting the color and retroreflectivity requirements of Departmental Specification DMS-8300, "Sign Face Materials." Type A or Type B reflective sheeting shall be supplied unless otherwise specified in the plans.
- The sheeting shall be suitable for use on and must adhere to the drum surface such that, under vertical impact, the sheeting shall remain adhered in-place and exhibit no delimiting, cracking, or loss of retroreflectivity other than that loss due to abrasion of the sheeting surface.

**BALLAST**

- Unballasted bases shall be large enough to hold up to 50 lbs. of sand. This base, when filled with the ballast material, should weigh between 35 lbs (minimum) and 50 lbs (maximum). The ballast may be sand in one to three sandbags separate from the base, sand in a sand-filled plastic bag, or other ballasting device as approved by the Engineer. Stacking of sandbags will be allowed, however height of sandbags above pavement surface may not exceed 12 inches.
- Bases with built-in ballast shall weigh between 40 lbs. and 50 lbs. Built-in ballast can be constructed of an integral drum rubber base or a solid rubber base.
- Recycled truck tires sidewalls may be used for ballast on drums approved for this type of ballast on the CWTCDL list.
- The ballast shall not be heavy objects, water, or any material that would become hazardous to motorists, pedestrians, or workers when the drum is struck by a vehicle.
- When used in regions susceptible to freezing, drums shall have drainage holes in the bottom so that water will not collect and freeze becoming a hazard when struck by a vehicle.
- Ballast shall not be placed on top of drums.
- Adhesives may be used to secure base of drums to pavement.

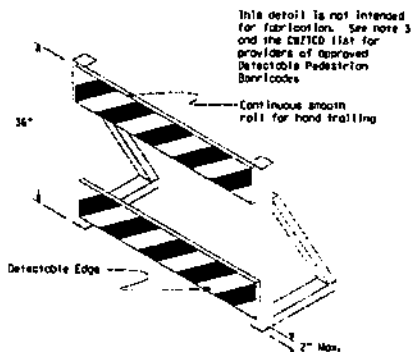
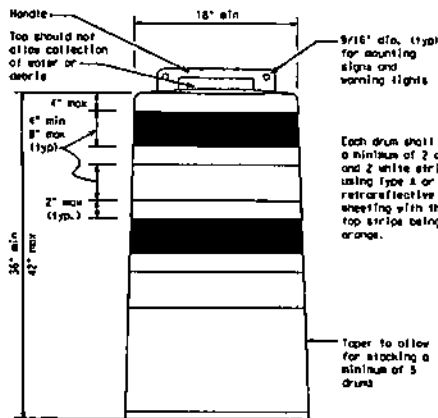

**DETECTABLE PEDESTRIAN BARRICADES**

- When existing pedestrian facilities are disrupted, closed, or relocated in a TTC zone, the temporary facilities shall be detectable and include accessibility features consistent with the features present in the existing pedestrian facility. Refer to 818.5-21 for Pedestrian control requirements for Sidewalk Diversions, Sidewalk Detours and Crosswalk Closures.
- When pedestrians with visual disabilities normally use the closed sidewalk, a Detectable Pedestrian Barricade shall be placed across the full width of the closed sidewalk instead of a Type 3 Barricade.
- Detectable pedestrian barricades similar to the one pictured above, longitudinal channelizing devices, some concrete barriers, and wood or chain link fencing with a continuous detectable edging can satisfactorily delineate a pedestrian path.
- Iron, rope, or plastic chain strapping between devices are not detectable, do not comply with the design standards in the "Americans with Disabilities Act Accessibility Guidelines (ADAAG)" and should not be used as a control for pedestrian movements.
- Warning lights shall not be attached to detectable pedestrian barricades.
- Detectable pedestrian barricades should use 8" nominal diameter rolls as shown on BC1010 provided that the top rolls provide a smooth continuous roll suitable for hand trailing with no splinters, burrs, or sharp edges.

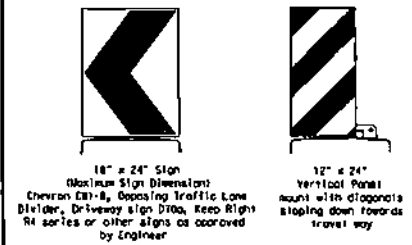

Plywood, Aluminum or Metal sign substrates shall NOT be used on plastic drums

**SIGNS, CHEVRONS, AND VERTICAL PANELS MOUNTED ON PLASTIC DRUMS**

- Signs used on plastic drums shall be manufactured using substrates listed on the CWTCDL.
- Chevrons and other work zone signs with an orange background shall be manufactured with Type B<sub>1</sub> or Type C<sub>1</sub> orange sheeting meeting the color and retroreflectivity requirements of DMS-8300, "Sign Face Material," unless otherwise specified in the plans.
- Vertical Panels shall be manufactured with orange and white sheeting meeting the requirements of DMS-8300 Type A or Type B. Diagonal stripes on Vertical Panels shall slope down toward the intended traveled lane.
- Other sign messages (text or symbolic) may be used as approved by the Engineer. Sign dimensions shall not exceed 18 inches in width or 24 inches in height, except for the R9 series signs discussed in note 8 below.
- Signs shall be installed using 1/2 inch bolt (nut and nut), two washers, and one locking washer for each connection.
- Mounting bolts and nuts shall be fully engaged and adequately torqued. Bolts should not extend more than 1/2 inch beyond nuts.
- Chevrons may be placed on drums on the outside of curves, on merging lanes or on shifting lanes. When used in these locations, they may be placed on every drum or spaced not more than on every third drum. A minimum of three (3) should be used at each location called for in the plans.
- R9-9, R9-10, R9-11 and R9-11a Sidewalk Closure signs which are 24 inches wide may be mounted on plastic drums, with approval of the Engineer.

SHEET B OF 12



**BARRICADE AND CONSTRUCTION CHANNELIZING DEVICES**

**BC (8) - 21**

DATE:	4-03 8-14
FILE:	9-07 5-21
	7-13



DISCLAIMER: The use of this information is governed by the "Texas Engineering Practice Act". No warranty of any kind is made by the State of Texas or any of its agencies for the use of this information for any purpose other than that for which it was prepared.

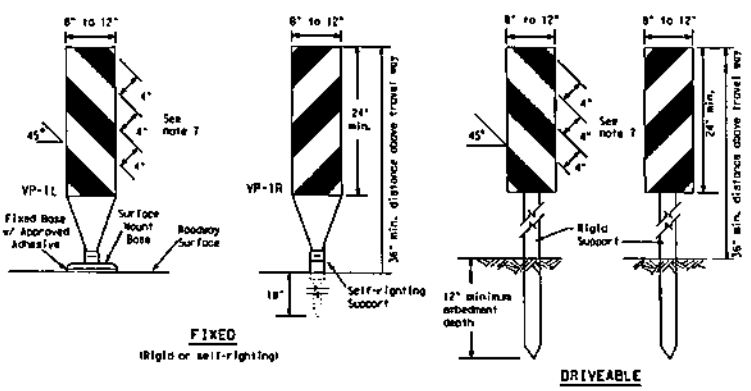

- Vertical Panels (VP's) are normally used to channelize traffic or divide opposing lanes of traffic.
- VP's may be used in daytime or nighttime situations. They may be used at the edge of shoulder drop-offs and other areas such as lane transitions where positive daytime and nighttime delineation is required. The Engineer/Inspector shall refer to the Roadway Design Manual for additional requirements on the use VP's for drop-offs.
- VP's should be mounted back to back if used at the edge of cuts adjacent to two-way two lane roadways. Stripes are to be reflective orange and reflective white and should always slope downward toward the travel lane.
- VP's used on expressways and freeways or other high speed roadways, may have more than 270 square inches of retroreflective area facing traffic.
- Self-righting supports are available with portable base. See "Compliant Work Zone Traffic Control Devices List" (CRZICD).
- Sheeting for the VP's shall be retroreflective Type A or Type B conforming to Departmental Material Specification DMS-8300, unless noted otherwise.
- Where the height of reflective material on the vertical panel is 36 inches or greater, a panel stripe of 6 inches shall be used.

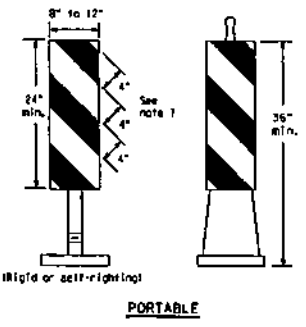

**VERTICAL PANELS (VP's)**

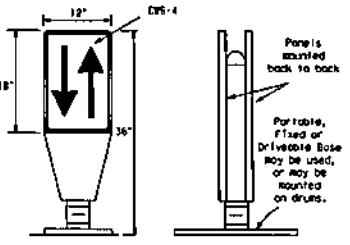

- Opposing Traffic Lane Dividers (OTLD) are delineation devices designed to convert a normal one-way roadway section to two-way operation. OTLD's are used on temporary centerlines. The upward and downward arrows on the sign's face indicate the direction of traffic on either side of the divider. The base is secured to the pavement with an adhesive or rubber weight to minimize movement caused by a vehicle impact or wind gust.
- The OTLD may be used in combination with 42" cones or VPs.
- Spacing between the OTLD shall not exceed 500 feet. 42" cones or VPs placed between the OTLD's should not exceed 100 foot spacing.
- The OTLD shall be orange with a black non-reflective legend. Sheeting for the OTLD shall be retroreflective Type B<sub>1</sub> or Type C<sub>1</sub> conforming to Departmental Material Specification DMS-8300, unless noted otherwise. The legend shall meet the requirements of DMS-8300.

**OPPOSING TRAFFIC LANE DIVIDERS (OTLD)**

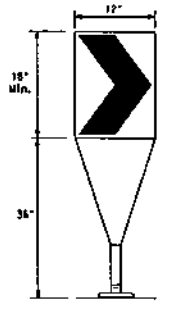

- The chevron shall be a vertical rectangle with a minimum size of 12 by 18 inches.
- Chevrons are intended to give notice of a sharp change of alignment with the direction of travel and provide additional emphasis and guidance for vehicle operators with regard to changes in horizontal alignment of the roadway.
- Chevrons, when used, shall be erected on the outside of a sharp curve or turn, or on the far side of an intersection. They shall be in line with and at right angles to approaching traffic. Spacing should be such that the motorist always has three in view, until the change in alignment eliminates its need.
- To be effective, the chevron should be visible for at least 500 feet.
- Chevrons shall be orange with a black nonreflective legend. Sheeting for the chevron shall be retroreflective Type B<sub>1</sub> or Type C<sub>1</sub> conforming to Departmental Material Specification DMS-8300, unless noted otherwise. The legend shall meet the requirements of DMS-8300.
- For Long Term Stationary use on tapers or transitions on freeways and divided highways, self-righting chevrons may be used to supplement plastic drums but not to replace plastic drums.

**CHEVRONS**

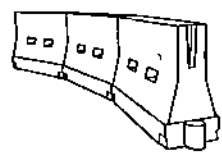

**LONGITUDINAL CHANNELIZING DEVICES (LCD)**

- LCDs are crushworthy, lightweight, deformable devices that are highly visible, have good target value and can be connected together. They are not designed to contain or redirect a vehicle on impact.
- LCDs may be used instead of a line of cones or drums.
- LCDs shall be placed in accordance to application and installation requirements specific to the device, and used only when shown on the CRZICD list.
- LCDs should not be used to provide positive protection for obstacles, pedestrians or workers.
- LCDs shall be supplemented with retroreflective delineation as required for temporary barriers on BECD when placed roughly parallel to the travel lanes.
- LCDs used as barricades placed perpendicular to traffic should have at least one row of reflective sheeting meeting the requirements for barricade rolls as shown on BECD. Place reflective sheeting near the top of the LCD along the full length of the device.

**WATER BALLASTED SYSTEMS USED AS BARRIERS**

- Water ballasted systems used as barriers shall not be used solely to channelize road users, but also to protect the work space per the appropriate Manual for Assessing Safety Hardware (MASH) crushworthy/rebar/requirements based on roadway speed and barrier application.
- Water ballasted systems used to channelize vehicular traffic shall be supplemented with retroreflective delineation or channelizing devices to improve daytime/nighttime visibility. They may also be supplemented with pavement markings.
- Water ballasted systems used as barriers shall be placed in accordance to application and installation requirements specific to the device, and used only when shown on the CRZICD list.
- Water ballasted systems used as barriers should not be used for a merging taper except in low speed (less than 45 MPH) urban areas. When used on a taper in a low speed urban area, the taper shall be delineated and the taper length should be designed to optimize road user operations considering the available geometric conditions.
- When water ballasted systems used as barriers have blunt ends exposed to traffic, they should be attenuated as per manufacturer recommendations or flared to a point outside the clear zone.

If used to channelize pedestrians, longitudinal channelizing devices or water ballasted systems must have a continuous detachable bottom for users of long cones and the top of the unit shall not be less than 32 inches in height.

**HOLLOW OR WATER BALLASTED SYSTEMS USED AS LONGITUDINAL CHANNELIZING DEVICES OR BARRIERS**

**GENERAL NOTES**

- Work Zone channelizing devices illustrated on this sheet may be installed in close proximity to traffic and are suitable for use on high or low speed roadways. The Engineer/Inspector shall ensure that spacing and placement is uniform and in accordance with the "Texas Manual on Uniform Traffic Control Devices" (TMUBCD).
- Channelizing devices shown on this sheet may have a drivable, fixed or portable base. The requirements for self-righting channelizing devices must be specified in the General Notes or other plan sheets.
- Channelizing devices on self-righting supports should be used in work zone areas where channelizing devices are frequently impacted by errant vehicles or vehicle related wind gusts making alignment of the channelizing devices difficult to maintain. Locations of these devices shall be detailed elsewhere in the plans. These devices shall conform to the TMUBCD and the "Compliant Work Zone Traffic Control Devices List" (CRZICD).
- The Contractor shall maintain devices in a clean condition and replace damaged, nonreflective, faded, or broken devices and bases as required by the Engineer/Inspector. The Contractor shall be required to maintain proper device spacing and alignment.
- Portable bases shall be fabricated from virgin and/or recycled rubber. The portable bases shall weigh a minimum of 30 lbs.
- Pavement surfaces shall be prepared in a manner that ensures proper bonding between the adhesives, the fixed mount bases on the pavement surface. Adhesives shall be prepared and applied according to the manufacturer's recommendations.
- The installation and removal of channelizing devices shall not cause detrimental effects to the final pavement surfaces, including pavement surface discoloration or surface integrity. Drivable bases shall not be permitted on final pavement surfaces. The Engineer/Inspector shall approve all application and removal procedures of fixed bases.

Posted Speed	Formula	Minimum Desirable Taper Lengths (ft)			Suggested Maximum Spacing of Channelizing Devices	
		10'	11'	12'	On a Roadway	On a Taper
30	L = WS <sup>2</sup> / 60	150'	165'	180'	30'	60'
35		205'	225'	245'	35'	70'
40	L = WS	265'	295'	320'	40'	80'
45		450'	495'	540'	45'	90'
50	L = WS	500'	550'	600'	50'	100'
55		550'	605'	660'	55'	110'
60	L = WS	600'	660'	720'	60'	120'
65		650'	715'	780'	65'	130'
70	L = WS	700'	770'	840'	70'	140'
75		750'	825'	900'	75'	150'
80	L = WS	800'	880'	960'	80'	160'
85		850'	945'	1020'	85'	170'

WS = Taper Length (ft) / Speed (MPH)  
L = Length of taper (ft) / S = Spacing of devices (ft) / S = Posted Speed (MPH)

**SUGGESTED MAXIMUM SPACING OF CHANNELIZING DEVICES AND MINIMUM DESIRABLE TAPER LENGTHS**

SHEET 9 OF 12



**BARRICADE AND CONSTRUCTION CHANNELIZING DEVICES**

BC (9) - 21

DATE:	FILE:
9-07	8-14
8-13	5-21

**TYPE 3 BARRICADES**

1. Refer to the Compliant Work Zone Traffic Control Devices List (ICR270) for details of the Type 3 Barricades and a list of all materials used in the construction of Type 3 Barricades.
2. Type 3 Barricades shall be used at each end of construction projects closed to all traffic.
3. Barricades extending across a roadway should have stripes that slope downward in the direction toward which traffic must turn in detouring. When both right and left turns are provided, the chevron striping may slope downward in both directions from the center of the barricade. Where no turns are provided at a closed road, striping should slope downward in both directions toward the center of roadway.
4. Striping of rolls, for the right side of the roadway, should slope downward to the left, for the left side of the roadway, striping should slope downward to the right.
5. Identification markings may be shown only on the back of the barricade rolls. The maximum height of letters and/or company logos used for identification shall be 1".
6. Barricades shall not be placed parallel to traffic unless an adequate clear zone is provided.
7. Warning signs shall not be installed on barricades.
8. Where barricades require the use of weights to keep from turning over, the use of sandbags with dry, construction sand is recommended. The sandbags will be tied shut to keep the sand from spilling and to maintain a constant weight. Sand bags shall not be stacked in a manner that covers any portion of a barricade roll's reflective striping. Rock, concrete, iron, steel or other solid objects will NOT be permitted. Sandbags should weigh a minimum of 35 lbs and a maximum of 50 lbs. Sandbags shall be made of a durable material that tears upon vehicular impact. Rubber (such as tire inner tubes) shall not be used for sandbags. Sandbags shall only be placed along or upon the base supports of the device and shall not be suspended above ground level or hung with rope, wire, chains or other fasteners.
9. Steering for barricades shall be retroreflective Type A or Type B conforming to Departmental Material Specification DMS-8300 unless otherwise noted.

Barricades shall NOT be used as a sign support.



**TYPICAL STRIPING DETAIL FOR BARRICADE RAIL**

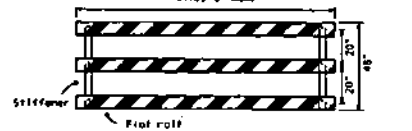

**TYPICAL PANEL DETAIL FOR SKID OR POST TYPE BARRICADES**

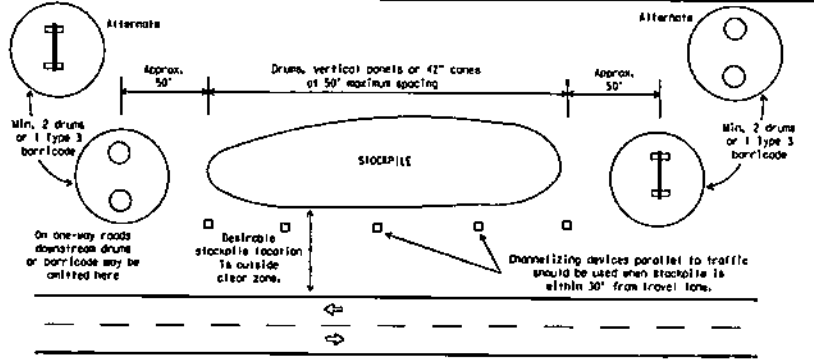

**TRAFFIC CONTROL FOR MATERIAL STOCKPILES**

Each roadway of a divided highway shall be barricaded in the same manner.

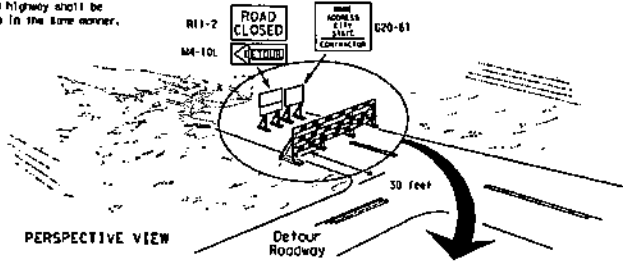

**PERSPECTIVE VIEW**

The three rolls on Type 3 barricades shall be reflectorized orange and reflective white stripes on one side facing one-way traffic and both sides for two-way traffic. Barricade striping should slant downward in the direction of detour.

1. Signs should be mounted on independent supports at a 7 foot mounting height in center of roadway. The signs should be a minimum of 10 feet behind Type 3 barricades.
2. Advance signing shall be as specified elsewhere in the plans.

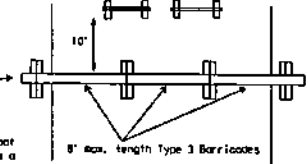

**PLAN VIEW**

**TYPE 3 BARRICADE (POST AND SKID) TYPICAL APPLICATION**

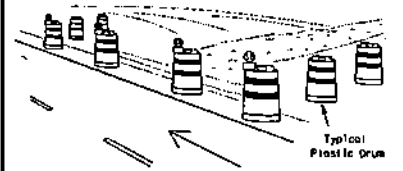

**PERSPECTIVE VIEW**

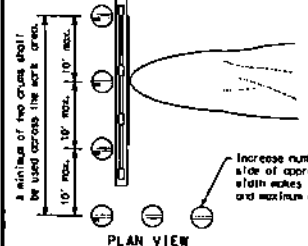

**PLAN VIEW**

1. Where positive redirection capability is provided, drums may be omitted.
2. Plastic construction fencing may be used with drums for safety as required in the plans.
3. Vertical panels on flexible support may be substituted for drums when the shoulder width is less than 4 feet.
4. When the shoulder width is greater than 12 feet, steady-burn lights may be omitted if drums are used.
5. Drums must extend the length of the culvert widening.

LEGEND	
	Plastic drum
	Plastic drum with steady burn light or yellow warning reflector
	Steady burn warning light or yellow warning reflector

Increase number of plastic drums on the side of approaching traffic if the crown width makes it necessary. Minimum of 2 and maximum of 4 drums.

**CULVERT WIDENING OR OTHER ISOLATED WORK WITHIN THE PROJECT LIMITS**

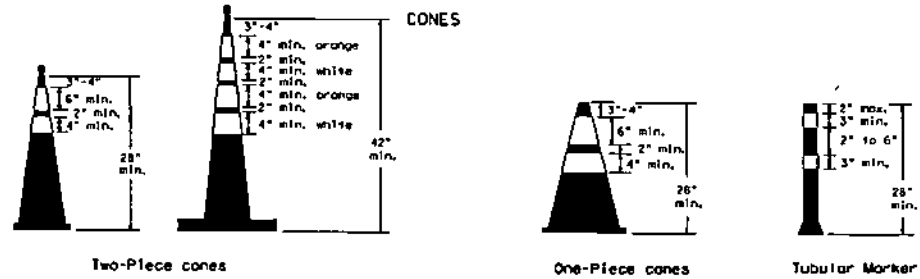

**CONES**

**Two-Piece cones**

**One-Piece cones**

**Tubular Marker**

28" Cones shall have a minimum weight of 9 1/2 lbs.  
42" 2-piece cones shall have a minimum weight of 30 lbs. including base.

1. Traffic cones and tubular markers shall be predominantly orange, and meet the height and weight requirements shown above.
2. One-piece cones have the body and base of the cone molded in one consolidated unit. Two-piece cones have a cone shaped body and a separate rubber base, or bolthead, that is added to keep the device upright and in place.
3. Two-piece cones may have a handle or loop extending up to 8" above the minimum height shown, in order to aid in re-erecting the device.
4. Cones or tubular markers shall have white or white and orange reflective bands as shown above. The reflective bands shall have a smooth, sealed outer surface and meet the requirements of Departmental Material Specification DMS-8300 Type A or Type B.
5. 28" cones and tubular markers are generally suitable for short duration and short-term stationary work as defined on BC14. These should not be used for intermediate-term or long-term stationary work unless personnel is on-site to maintain them in their proper upright position.
6. 42" two-piece cones, vertical panels or drums are suitable for all work zone durations.
7. Cones or tubular markers used on each project should be of the same size and shape.

SHEET 10 OF 12



**BARRICADE AND CONSTRUCTION CHANNELIZING DEVICES**

BC (10) - 21

9-07	8-14
7-83	5-21

## WORK ZONE PAVEMENT MARKINGS

### GENERAL

- The Contractor shall be responsible for maintaining work zone and existing pavement markings, in accordance with the standard specifications and special provisions, on all roadways open to traffic within the CSJ limits unless otherwise stated in the plans.
- Color, patterns and dimensions shall be in conformance with the "Texas Manual on Uniform Traffic Control Devices" (TMUTCD).
- Additional supplemental pavement marking details may be found in the plans or specifications.
- Pavement markings shall be installed in accordance with the TMUTCD and as shown on the plans.
- When alternate markings are required on the plans, short term markings shall conform with the TMUTCD, the plans and details as shown on the Standard Plan Sheet 8215THA.
- When standard pavement markings are not in place and the roadway is opened to traffic, DO NOT PASS signs shall be erected to mark the beginning of the sections where passing is prohibited and PASS WITH CARE signs at the beginning of sections where passing is permitted.
- All work zone pavement markings shall be installed in accordance with Item 662, "Work Zone Pavement Markings."

### RAISED PAVEMENT MARKERS

- Raised pavement markers are to be placed according to the patterns on BC112I.
- All raised pavement markers used for work zone markings shall meet the requirements of Item 672, "RAISED PAVEMENT MARKERS" and Departmental Material Specification DMS-4200 or DMS-4300.

### PREFABRICATED PAVEMENT MARKINGS

- Removable prefabricated pavement markings shall meet the requirements of DMS-6241.
- Non-removable prefabricated pavement markings (fall back) shall meet the requirements of DMS-6240.

### MAINTAINING WORK ZONE PAVEMENT MARKINGS

- The Contractor shall be responsible for maintaining work zone pavement markings within the work limits.
- Work zone pavement markings shall be inspected in accordance with the frequency and reporting requirements of work zone traffic control device inspections as required by Form 595.
- The markings should provide a visible reference for a minimum distance of 300 feet during normal daylight hours and 150 feet when illuminated by automobile low-beam headlights at night, unless sight distance is restricted by roadway geometrics.
- Markings failing to meet this criteria within the first 30 days after placement shall be replaced at the expense of the Contractor as per Specification Item 662.

### REMOVAL OF PAVEMENT MARKINGS

- Pavement markings that are no longer applicable, could create confusion or direct a motorist toward or into the closed portion of the roadway shall be removed or obliterated before the roadway is opened to traffic.
- The above shall not apply to detours in place for less than three days, where flaggers or other sufficient channelizing devices are used in lieu of markings to outline the detour route.
- Pavement markings shall be removed to the fullest extent possible, so as not to leave a discernible marking. This shall be by any method approved by TxDOT Specification Item 677 for "Eliminating Existing Pavement Markings and Markers".
- The removal of pavement markings may require resurfacing or seal coating portions of the roadway as described in Item 677.
- Subject to the approval of the Engineer, any method that proves to be successful on a particular type pavement may be used.
- Broad cleaning may be used but will not be required unless specifically shown in the plans.
- Over-painting of the markings shall NOT be permitted.
- Removal of raised pavement markers shall be as directed by the Engineer.
- Removal of existing pavement markings and markers will be paid for directly in accordance with Item 677, "ELIMINATING EXISTING PAVEMENT MARKINGS AND MARKERS," unless otherwise stated in the plans.
- Black-out marking tape may be used to cover conflicting existing markings for periods less than two weeks when approved by the Engineer.

## Temporary Flexible-Reflective Roadway Marker Tabs

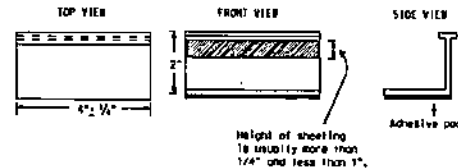

**STAPLES OR NAILS SHALL NOT BE USED TO SECURE  
TEMPORARY FLEXIBLE-REFLECTIVE ROADWAY MARKER  
TABS TO THE PAVEMENT SURFACE**

- Temporary flexible-reflective roadway marker tabs used as guidemarks shall meet the requirements of DMS-6242.
- Tabs detailed on this sheet are to be inspected and accepted by the Engineer or designated representative. Sampling and testing is not normally required, however at the option of the Engineer, either "A" or "B" below may be imposed to ensure quality before placement on the roadway.
  - Select five (5) or more tabs of random from each lot or shipment and submit to the Construction Division, Materials and Pavement Section to determine specification compliance.
  - Select five (5) tabs and perform the following test. Affix five (5) tabs at 24 inch intervals on an asphaltic pavement in a straight line. Using a medium size passenger vehicle or pickup, run over the markers with the front and rear tires at a speed of 35 to 40 miles per hour, four (4) times in each direction. No more than one (1) out of the five (5) reflective surfaces shall be lost or displaced as a result of this test.
- Small design variances may be noted between tab manufacturers.
- See Standard Sheet 8215THA for tab placement on new pavements. See Standard Sheet TCR13-19 for tab placement on seal coat work.

### RAISED PAVEMENT MARKERS USED AS GUIDEMARKS

- Raised pavement markers used as guidemarks shall be from the approved product list, and meet the requirements of DMS-4200.
- All temporary construction raised pavement markers provided on a project shall be of the same manufacturer.
- Adhesive for guidemarks shall be bituminous material hot applied or butyl rubber pad for all surfaces, or thermoplastic for concrete surfaces.

Guidemarks shall be designated as:  
 YELLOW - two amber reflective surfaces with yellow body.  
 WHITE - one silver reflective surface with white body.

DEPARTMENTAL MATERIAL SPECIFICATIONS	
PAVEMENT MARKERS (REFLECTORIZED)	DMS-4200
TRAFFIC BUTTONS	DMS-4300
EPOXY AND ADHESIVES	DMS-6100
BITUMINOUS ADHESIVE FOR PAVEMENT MARKERS	DMS-6130
PERMANENT PREFABRICATED PAVEMENT MARKINGS	DMS-6240
TEMPORARY REMOVABLE, PREFABRICATED PAVEMENT MARKINGS	DMS-6241
TEMPORARY FLEXIBLE, REFLECTIVE ROADWAY MARKER TABS	DMS-6242

A list of prequalified reflective raised pavement markers, non-reflective traffic buttons, roadway marker tabs and other pavement markings can be found at the Material Producer List web address shown on BC111.

SHEET 11 OF 12

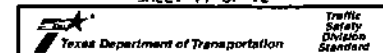

## BARRICADE AND CONSTRUCTION PAVEMENT MARKINGS

BC(11)-21

DATE	BY	CHECKED	DATE
2-98	9-07	5-21	
1-02	1-13		
11-02	8-14		

DISCLAIMER: The use of this program is governed by the "Traffic Engineering Practices Manual" for the state of Texas. This manual is available to other persons for purchase or for information. The user assumes all liability for the use of this program.

### PAVEMENT MARKING PATTERNS



REFLECTORIZED PAVEMENT MARKINGS - PATTERN A

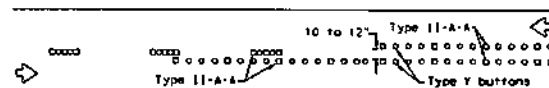

RAISED PAVEMENT MARKERS - PATTERN A

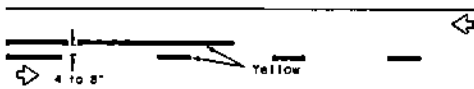

REFLECTORIZED PAVEMENT MARKINGS - PATTERN B

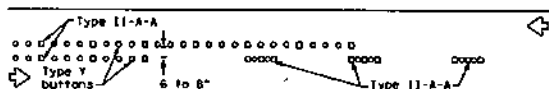

RAISED PAVEMENT MARKERS - PATTERN B

Pattern A is the ESDOT Standard, however Pattern B may be used if approved by the Engineer. Prefabricated markings may be substituted for reflectorized pavement markings.

### CENTER LINE & NO-PASSING ZONE BARRIER LINES FOR TWO-LANE, TWO-WAY HIGHWAYS

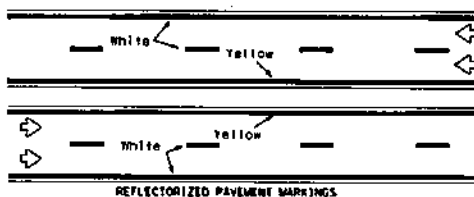

REFLECTORIZED PAVEMENT MARKINGS

Prefabricated markings may be substituted for reflectorized pavement markings.

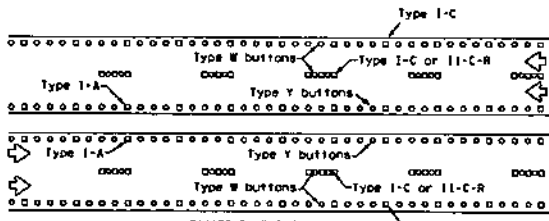

RAISED PAVEMENT MARKERS

### EDGE & LANE LINES FOR DIVIDED HIGHWAY

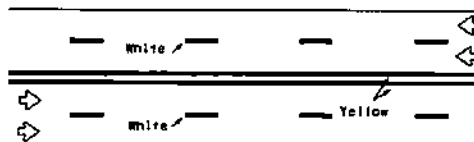

REFLECTORIZED PAVEMENT MARKINGS

Prefabricated markings may be substituted for reflectorized pavement markings.

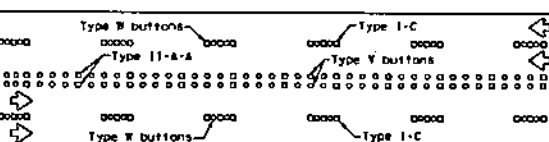

RAISED PAVEMENT MARKERS

### LANE & CENTER LINES FOR MULTILANE UNDIVIDED HIGHWAYS

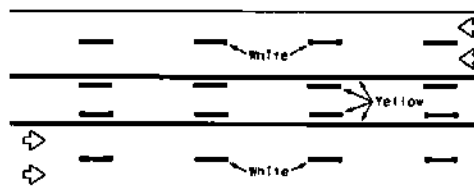

REFLECTORIZED PAVEMENT MARKINGS

Prefabricated markings may be substituted for reflectorized pavement markings.

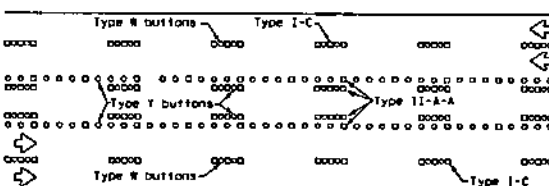

RAISED PAVEMENT MARKERS

### TWO-WAY LEFT TURN LANE

### STANDARD WORK ZONE PAVEMENT MARKINGS DETAILS

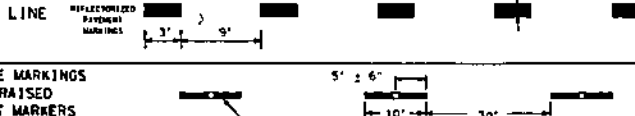
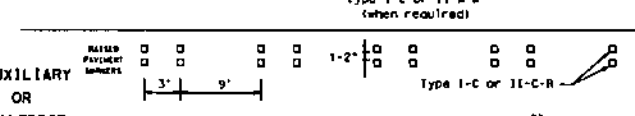
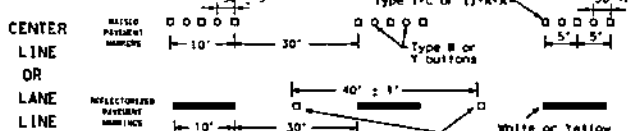
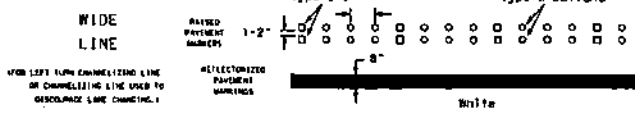
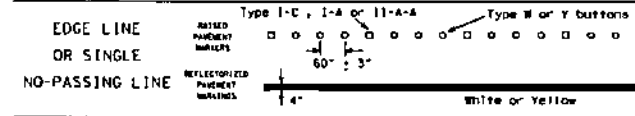

SOLID LINES

BROKEN LINES

REMOVABLE MARKINGS WITH RAISED PAVEMENT MARKERS

If raised pavement markers are used to supplement REMOVABLE markings, the markers shall be applied to the top of the top of the approximate mid length of tape used for broken lines or at 20 foot spacing for solid lines. This allows an easier removal of raised pavement markers and tape.

Centerline only - not to be used on edge lines and tape.

SHEET 12 OF 12

Texas Department of Transportation  
Traffic Safety Division Standard

### BARRICADE AND CONSTRUCTION PAVEMENT MARKING PATTERNS

BC (12) - 21

1-91	5-07	5-21	
2-98	7-13		
11-02	8-14		

Raised pavement markers used as standard pavement markings shall be from the approved products list and meet the requirements of Item 672 "RAISED PAVEMENT MARKERS."

DATE FILED

**GENERAL CONDITIONS FOR  
WEBB COUNTY CONSTRUCTION CONTRACT  
TABLE OF CONTENTS**

<b>ARTICLE I. GENERAL PROVISIONS</b>	<b>6</b>
1.1 CONTRACT DEFINITIONS	6
1.2 PRELIMINARY MATTERS	11
1.3 CONTRACT DOCUMENTS	12
<b>ARTICLE II. WEBB COUNTY</b>	<b>16</b>
2.1 GENERAL	16
2.2 INFORMATION AND SERVICES TO BE PROVIDED BY WEBB COUNTY	16
<b>ARTICLE III. CONTRACTOR</b>	<b>18</b>
3.1 GENERAL	18
3.2 REVIEW OF CONTRACT DOCUMENTS AND FIELD CONDITIONS BY CONTRACTOR	18
3.3 SUPERVISION AND CONSTRUCTION PROCEDURES	19
3.4 LABOR AND MATERIALS	21
3.5 WARRANTY	24
3.6 TAXES.	26
3.7 PERMITS, FEES AND NOTICES	26
3.8 ALLOWANCES	27
3.9 SUPERINTENDENT/KEY PERSONNEL	28
3.10 CONTRACTOR'S PROJECT SCHEDULES	29
3.11 DOCUMENTS AND SAMPLES AT THE SITE	37
3.12 SHOP DRAWINGS, PRODUCT DATA AND SAMPLES	38
3.13 USE OF SITE	40
3.14 CUTTING AND PATCHING	41
3.15 CLEANING UP	41
3.16 ACCESS TO WORK.	42
3.17 PATENT FEES AND ROYALTIES.	42

Rev.392021

Webb County General Conditions  
Pueblo Nuevo Street Improvement Project Contract CDV21-0485 (I.T.B. 2023-004)  
Webb County, Owner – Anderson Columbia Co., Inc., Contractor



3.18	INDEMNITY PROVISIONS	42
3.19	REPRESENTATIONS AND WARRANTIES.	45
3.20	BUSINESS STANDARDS.	45
ARTICLE IV. ADMINISTRATION OF THE CONTRACT		45
41	DESIGN CONSULTANT.	45
42	ROLES IN ADMINISTRATION OF THE CONTRACT	46
43	CLAIMS AND DISPUTES	47
4.4	RESOLUTION OF CLAIMS AND DISPUTES	52
4.5	ALTERNATIVE DISPUTE RESOLUTION	53
4.6	INTERNET-BASED PROJECT MANAGEMENT SYSTEMS.	54
ARTICLE V. SUBCONTRACTORS		54
5.1	DEFINITION	54
5.2	AWARD OF SUBCONTRACTS AND OTHER CONTRACTS FOR PORTIONS OF THE WORK	55
5.3	SUB-CONTRACTUAL RELATIONS	55
5.4	CONTINGENT ASSIGNMENT OF SUBCONTRACTS	56
ARTICLE VI. CONSTRUCTION BY WEBB COUNTY OR BY SEPARATE CONTRACTS		56
6.1	WEBB COUNTY'S RIGHT TO PERFORM CONSTRUCTION AND TO AWARD SEPARATE CONTRACTS	56
6.2	MUTUAL RESPONSIBILITY	57
6.3	WEBB COUNTY'S RIGHT TO CLEAN UP.	58
ARTICLE VII. CHANGES IN THE WORK		58
7.1	GENERAL	58
7.2	CHANGE ORDERS	58
7.3	FIELD WORK DIRECTIVES	59
7.4	MINOR CHANGES TO THE WORK.	61
7.5	TIME REQUIRED TO PROCESS CHANGE ORDERS	61
ARTICLE VIII. TIME		62
8.1	PROGRESS AND COMPLETION	62

8.2	DELAYS AND EXTENSIONS OF TIME	62
	ARTICLE IX. PAYMENTS AND COMPLETION	63
91	CONTRACT SUM.	63
92	SCHEDULE OF VALUES	63
93	APPLICATIONS FOR PAYMENT	63
94	PAY APPLICATION APPROVAL	64
95	DECISIONS TO REJECT APPLICATION FOR PAYMENT	65
9.6	PROGRESS PAYMENTS	66
9.7	SUBSTANTIAL COMPLETION	67
9.8	PARTIAL OCCUPANCY OR USE	68
9.9	FINAL COMPLETION AND FINAL PAYMENT	69
9.10	ADDITIONAL INSPECTIONS.	70
	ARTICLE X. PROTECTION OF PERSONS AND PROPERTY	70
10.1	SAFETY PRECAUTIONS AND PROGRAMS	70
10.2	SAFETY OF PERSONS AND PROPERTY	71
10.3	EMERGENCIES	73
10.4	PUBLIC CONVENIENCE AND SAFETY	73
10.5	BARRICADES, LIGHTS AND WATCHMEN.	74
10.6	PUBLIC UTILITIES AND OTHER PROPERTIES TO BE CHANGED.	74
10.7	TEMPORARY STORM SEWER AND DRAIN CONNECTIONS.	74
10.8	ARRANGEMENT AND CHARGE FOR WATER, ELECTRICAL OR WIRELESS ACCESS FOR THE PROJECT	75
10.9	USE OF FIRE HYDRANTS.	75
10.10	ENVIRONMENTAL COMPLIANCE	75
	ARTICLE XI. INSURANCE AND BONDS	76
11.1	CONTRACTOR'S LIABILITY INSURANCE	76
11.2	PROPERTY INSURANCE	81
11.3	PERFORMANCE BONDS AND PAYMENT BONDS	82

11.4	'UMBRELLA' LIABILITY INSURANCE.	84
11.5	POLICY ENDORSEMENTS AND SPECIAL CONDITIONS	84
	<b>ARTICLE XII. INSPECTING, UNCOVERING AND CORRECTING OF WORK</b>	<b>86</b>
121	INSPECTING WORK	86
122	UNCOVERING WORK	87
123	CORRECTING WORK	87
124	ACCEPTANCE OF NONCONFORMING WORK	88
	<b>ARTICLE XIII. COMPLETION OF THE CONTRACT; TERMINATION; TEMPORARY SUSPENSION</b>	<b>89</b>
13.1	FINAL COMPLETION OF CONTRACT	89
13.2	WARRANTY FULFILLMENT	89
13.3	TERMINATION BY WEBB COUNTY FOR CAUSE	89
13.4	TEMPORARY SUSPENSION OF THE WORK	92
	<b>ARTICLE XIV. MISCELLANEOUS PROVISIONS</b>	<b>93</b>
141	GOVERNING LAW; COMPLIANCE WITH LAWS AND REGULATIONS	93
142	SUCCESSORS AND ASSIGNS.	93
143	WRITTEN NOTICE.	93
144	RIGHTS AND REMEDIES; NO WAIVER OF RIGHTS BY WEBB COUNTY	93
145	INTEREST	94
146	INDEPENDENT MATERIALS TESTING AND INSPECTION	94
147	OFFICERS OR EMPLOYEES OF WEBB COUNTY NOT TO HAVE FINANCIAL INTEREST IN ANY CONTRACT OF WEBB COUNTY.	94
148	Venue.	95
149	INDEPENDENT CONTRACTOR.	95
1410	NON-DISCRIMINATION.	95
1411	GIFTS TO PUBLICSERVANTS	95
	<b>ARTICLE XV. AUDIT</b>	<b>96</b>
151	RIGHT TO AUDIT CONTRACTOR'S RECORDS.	96

<b>ARTICLE XVI. ATTORNEY FEES</b>	<b>96</b>
<b>SPECIAL CONDITIONS FOR HORIZONTAL PROJECTS</b>	<b>97</b>
<b>3.2.5 Differing Site Conditions (Adds this Section 3.2.5 to GENERAL CONDITIONS FOR WEBB COUNTY CONSTRUCTION CONTRACTS)</b>	<b>97</b>
<b>3.4.7 Material Testing (Added to Section 3.4.7 of GENERAL CONDITIONS FOR WEBB COUNTY CONSTRUCTION CONTRACTS)</b>	<b>97</b>
<b>7.2.5 Allowable Markups (Added to Section 7.2.5 of GENERAL CONDITIONS FOR WEBB COUNTY CONSTRUCTION CONTRACTS)</b>	<b>98</b>
<b>7.2.5.1 Labor</b>	<b>98</b>
<b>7.2.5.2 Materials</b>	<b>98</b>
<b>7.2.5.3 Equipment</b>	<b>99</b>
<b>7.2.5.4 Subcontractor Markups</b>	<b>99</b>
<b>7.3.9 Field Work Directive Allowable Markups (Adds this Section 7.3.9 to GENERAL CONDITIONS FOR WEBB COUNTY CONSTRUCTION CONTRACTS)</b>	<b>99</b>
<b>8.2.2 Standby Equipment Costs (Added to Section 8.2.2 of GENERAL CONDITIONS FOR WEBB COUNTY CONSTRUCTION CONTRACTS)</b>	<b>99</b>
<b>10.11 Road Closures and Detour Routes (Adds this Section 10.11 to GENERAL CONDITIONS FOR WEBB COUNTY CONSTRUCTION CONTRACTS)</b>	<b>100</b>
<b>10.12 Use of WEBB COUNTY Streets (Adds this Section 10.12 to GENERAL CONDITIONS FOR WEBB COUNTY CONSTRUCTION CONTRACTS)</b>	<b>100</b>
<b>10.13 Maintenance of Traffic (Adds this Section 10.13 to GENERAL CONDITIONS FOR WEBB COUNTY CONSTRUCTION CONTRACTS)</b>	<b>101</b>
<b>10.14 Abatement and Mitigation of Excessive or Unnecessary Construction Noise (Adds this Section 10.14 to GENERAL CONDITIONS FOR WEBB COUNTY CONSTRUCTION CONTRACTS)</b>	<b>101</b>
<b>10.15 Incidental Work, Connections, and Passageways (Adds Section 10.15 to GENERAL CONDITIONS FOR WEBB COUNTY CONSTRUCTION CONTRACTS)</b>	<b>101</b>

# GENERAL CONDITIONS FOR WEBB COUNTY CONSTRUCTION CONTRACTS

## ARTICLE I. GENERAL PROVISIONS

### 1.1 CONTRACT DEFINITIONS

Wherever used in the Contract Documents and printed with initial capital letters, the terms listed below shall have the meanings indicated, which are applicable to both the singular and plural thereof.

1.11 **“ALTERNATE”** means a variation in the Work in which WEBB COUNTY requires a price separate from the Base Bid. If an Alternate is accepted by WEBB COUNTY, the variation shall become a part of the Contract through award of the Contract and the Base Bid shall be adjusted to include the amount quoted as stated in the Notice of Award to Contractor. If an Alternate is accepted by WEBB COUNTY, and later deleted, WEBB COUNTY shall be entitled to a credit in the full value of the Alternate as priced in Contractor’s Bid Proposal.

1.12 **“AMENDMENT”** is a written modification of the Contract prepared by WEBB COUNTY or Design Consultant and signed by WEBB COUNTY and Contractor, (and approved by the WEBB COUNTY COMMISSIONERS COURT, if required) which authorizes an addition, deletion or revision in the Work (specifically the services) or an adjustment in the Contract Sum or the Contract Times and is issued on or after the Effective Date of the Contract.

1.13 **“BASE BID”** is the price quoted for the Work before Alternates are considered.

1.14 **“CHANGE ORDER”** refer to **Article VII** herein for definition.

1.15 **“WEBB COUNTY”** is defined in **Article II** herein.

1.16 **“WEBB COUNTY COMMISSIONERS COURT”** means the duly elected members of the WEBB COUNTY COMMISSIONERS COURT of WEBB COUNTY, Texas.

1.17 **“CONSTRUCTION OBSERVER/INSPECTOR** (hereafter referred to as “COI”) is the authorized representative of WEBB COUNTY to observe and inspect any or all parts of the Project and the materials to be used therein. Also referred to herein as Resident Inspector.

1.18 **“CONTRACT”** means the Contract Documents which represent the entire and integrated agreement between WEBB COUNTY and Contractor and supersede all prior negotiations, representations or agreements, either written or oral. The terms and conditions of the Contract Documents may be changed only in writing by a Field Work Directive, Change Order or Amendment. The Contract Documents shall not be construed to create a contractual relationship of any kind between:

- (1) Design Consultant and Contractor;



- (2) WEBB COUNTY and a Subcontractor or Sub-Subcontractor; or
- (3) any persons or entities other than WEBB COUNTY and Contractor.

1.19 **“CONTRACT DOCUMENTS”** means the Construction Contract between WEBB COUNTY and Contractor, which consists of, but is not limited to, the following: the solicitation documents, the Notice of Award, an enabling WEBB COUNTY Ordinance and all other contract-related documents, which include:

- (1) General Conditions;
- (2) Vertical and/or Horizontal specific General Conditions and Special Conditions included by Special Provisions or addenda;
- (3) Drawings;
- (4) Specifications;
- (5) addenda issued prior to the close of the solicitation period;
- (6) other documents listed in the Contract, including Field Work Directives, Change Orders and/or Amendments; and
- (7) a written order for a minor change in the Work issued by Design Consultant and/or WEBB COUNTY, as described in **Article VII** herein.

The geotechnical and subsurface reports, which WEBB COUNTY may have provided to Contractor, specifically are excluded from the Contract Documents.

1.110 **“CONTRACT TIME”** means, unless otherwise provided, the period of time, including any authorized adjustments, allotted in the Contract Documents for Substantial Completion of the Work. When the plural (“Contract Times”) is used, it refers to milestones designated in the Work Progress Schedule.

1.111 **“CONTRACTOR”** means the entity entering into a Contract with WEBB COUNTY to complete the Work. Contractor, as used herein, includes Construction Manager at Risk or other applicable entities performing work under a Contract with WEBB COUNTY.

1.112 **“DAY”** as used in the Contract Documents shall mean Calendar Day, unless otherwise specifically defined. A Calendar Day is a day of 24 hours, measured from midnight to the next midnight, unless otherwise specifically stipulated. For Projects not affecting WEBB COUNTY traffic, a determination made solely by WEBB COUNTY on a project-by-project basis, a Working Day is measured from sunrise to sundown Monday through Friday, except legal holidays, or the hours during which Contractor has been authorized and/or directed to work by WEBB COUNTY. For Projects affecting WEBB COUNTY traffic, a determination made solely by WEBB COUNTY on a project-by-project basis, a working day shall mean sunrise to sundown Monday through

Saturday, except legal holidays, or hours during which Contractor has been authorized and/or directed to work by WEBB COUNTY.

1.1.13 “DEPARTMENT” means the Webb County Engineering Department

1.1.14 “DESIGN CONSULTANT” means, unless the context clearly indicates otherwise, an Engineer, Architect or other Design Consultant in private practice, licensed to do work in Texas and retained for a specific project under a contractual agreement with WEBB COUNTY. In the event there is no private Engineer, Architect or other Design Consultant then the DEPARTMENT ENGINEER is the DESIGN CONSULTANT.

1.1.15 “DEEMS” AND/OR “DEEMED” means objectively and reasonably determined..

1.1.16 “DRAWINGS” (also referred to herein as “Plans”) are the graphic and pictorial portions of the Contract Documents, wherever located and whenever issued, showing the design, location and dimensions of Work, generally including elevations, sections, details, schedules and diagrams.

1.1.17 Failings, neglect, defaults have to be substantial, material and/or significant as to result in loss or cost in more than nominal.

1.1.18 “FIELD WORK DIRECTIVES” OR “FORCE ACCOUNT” is a written order signed by WEBB COUNTY directing a change in the Work prior to agreement and adjustment, if any, in the Contract Sum and/or Contract, as further defined in **Section 7.3** herein.

1.1.19 “HAZARDOUS SUBSTANCE” is defined to include the following:

- (a) any asbestos or any material which contains any hydrated mineral silicate, including chrysolite, amosite, crocidolite, tremolite, anthophyllite or actinolite, whether friable or non-friable;
- (b) any polychlorinated biphenyls (“PCBs”), or PCB-containing materials, or fluids;
- (c) radon;
- (d) any other hazardous, radioactive, toxic or noxious substance, material, pollutant, or solid, liquid or gaseous waste; any pollutant or contaminant (including but not limited to petroleum, petroleum hydrocarbons, petroleum products, crude oil or any fractions thereof, any oil or gas exploration or production waste, any natural gas, synthetic gas or any mixture thereof, lead, or other toxic metals) which in its condition, concentration or area of release could have a significant effect on human health, the environment, or natural resources;
- (e) any substance, whether by its nature or its use, is subject to regulation or requires environmental investigation, monitoring, or remediation under any federal, state, or local environmental laws, rules, or regulations;

- (f) any underground storage tanks, as defined in 42 U.S.C. Section 6991(1)(A)(i) (including those defined by Section 9001(1) of the 1984 Hazardous and Solid Waste Amendments to the Resource Conservation and Recovery Act, 42 U.S.C. Section 6901 et seq.;
- (g) the Texas Water Code Annotated Section 26.344; and Title 30 of the Texas Administrative Code Sections 334.3 and 334.4), whether empty, filled or partially filled with any substance; and
- (h) any other hazardous material, hazardous waste, hazardous substance, solid waste, and toxic substance as those or similar terms are defined under any federal, state, or local environmental laws, rules, or regulations.

1.120 **"LIQUIDATED DAMAGES"** reflect the daily monetary compensation, as designated in the Project's solicitation documents, to be paid to WEBB COUNTY by Contractor for losses/damages incurred by WEBB COUNTY as a result of Contractor's failure to achieve the contractual dates for Substantial Completion and/or Final Completion of the Project.

1.121 **"NOTICE TO PROCEED (HEREIN ALSO REFERRED TO AS "WORK PROJECT AUTHORIZATION" OR "NTP")"** is a written notice given by WEBB COUNTY to Contractor establishing the date on which the Contract Time shall commence to run and the date on which Contractor may begin performance of its contractual obligations.

1.122 **"OWNER"** is defined in **Article II** herein.

1.123 **"OWNER'S DESIGNATED REPRESENTATIVE (ODR)"** means the person(s) designated by WEBB COUNTY to act for WEBB COUNTY.

1.124 **"PARTY"** shall refer to WEBB COUNTY or Contractor individually herein.

1.125 **"PARTIES"** shall refer to WEBB COUNTY and Contractor collectively herein.

1.126 **"PROJECT"** means the total design and construction of Work performed under the Contract Documents and may be the whole or a part of the Project and which may include construction by WEBB COUNTY or by separate contractors. All references in these General Conditions to or concerning the Work or the Site of the Work shall use the term "Project," notwithstanding the Work referenced only may be a part of the Project.

1.127 **"PROJECT MANAGEMENT TEAM"** is composed of WEBB COUNTY, its representatives, Design Consultant and Program Manager (if any) for this Work.

1.128 **"SITE"** means the land(s) or area(s) (as indicated in the Contract Documents) furnished by WEBB COUNTY, upon which the Work is to be performed, including rights-of-way and easements for access thereto, and such other lands furnished by WEBB COUNTY which are designated for the use of Contractor.

1.129 **“SPECIAL CONDITIONS”** are terms and conditions to a contractual agreement which supplement and are superior to these General Conditions and grant greater authority or impose greater restrictions upon Contractor, beyond those granted or imposed in these General Conditions. WEBB COUNTY’s Horizontal Special Conditions are attached hereto, made a part of these General Conditions and shall be used as applicable.

1.130 **“SPECIFICATIONS”** are those elements of the Contract Documents consisting of the written requirements for materials, equipment, construction systems, standards, workmanship for the Work, performance of related services and other technical requirements.

1.131 **“SUBSTANTIAL COMPLETION”** is the date certified by WEBB COUNTY and Design Consultant, in accordance with **Section 9.8** herein, when the Work, or a designated portion thereof, is sufficiently complete in accordance with the Contract Documents so as to be operational and fit for the intended use by WEBB COUNTY.

1.132 **“TEMPORARY BENCH MARKS (TBM)”** are temporary affixed marks which establish the exact elevation of a place; TBMs are used by surveyors in measuring site elevations or as a starting point for surveys.

1.133 **“THE 3D MODEL”** is the Building Information Model prepared by Design Consultant in the format designated, approved and acceptable to WEBB COUNTY with databases of materials, products and systems available for use by Contractor to prepare schedules for cost estimating, product and materials placement schedules and evaluations of crash incidences. The 3D Model, if available, may be used as a tool, however all information taken from the Model is the responsibility of Contractor and not WEBB COUNTY or Design Consultant.

1.134 **“WORK”** means the construction and services required by the Contract Documents, whether completed or partially completed, and includes all labor, materials, equipment and services provided or to be provided by Contractor, or any Subcontractors, Sub-Subcontractors, material suppliers or any other entities for which Contractor is responsible, to fulfill the Contractor’s obligations. The Work may constitute the whole or a part of the Project.

1.135 **OTHER DEFINITIONS.** As used in the Contract Documents, the following additional terms have the following meanings:

- 1.1.33.1 “provide” means to furnish, install, fabricate, deliver and erect, including all services, materials, appurtenances and all other expenses necessary to complete in place and ready for operation or use;
- 1.1.33.2 “shall” means the mandatory action of the Party of which reference is being made;
- 1.1.33.3 “as required” means as prescribed in the Contract Documents; and
- 1.1.33.4 “as necessary” means all action essential or needed to complete the work in accordance with the Contract Documents and applicable laws, ordinances, construction codes and regulations.

## 1.2 PRELIMINARY MATTERS

1.2.1 Upon the WEBB COUNTY Commissioners Court's award of the project, a Notice of Award Letter shall be sent to Contractor by WEBB COUNTY, notifying Contractor of the award of a contract. In its Notice of Award Letter, Contractor shall be informed of a date certain by which Contractor's bond(s) and evidence of insurance shall be delivered to WEBB COUNTY.

1.2.2 **DELIVERY OF CONTRACT AND BONDS.** Not later than the Pre-Construction meeting and prior to the commencement of any Work on the Project, Contractor shall deliver a fully executed Contract to WEBB COUNTY, along with such bonds as Contractor may be required to furnish, including, but not limited to, a required payment bond in the form and amount specified in the Contract Documents and these General Conditions and a required performance bond in the form and amount specified in the Contract Documents and these General Conditions.

1.2.3 **DELIVERY OF EVIDENCE OF INSURANCE.** Not later than the Pre-Construction meeting, and prior to the commencement of any Work under this Contract, Contractor shall deliver evidence of insurance to WEBB COUNTY. Contractor shall furnish an original completed Certificate of Insurance and a copy of all insurance policies, together with all required endorsements thereto, required by the Contract Documents to WEBB COUNTY, or its delegated department, clearly labeled with the name of the Project and which shall contain all information required by the Contract Documents. Contractor shall be prohibited from commencing the Work and WEBB COUNTY shall have no duty to pay or perform under this Contract until such evidence of insurance is delivered to WEBB COUNTY. No officer or employee, other than WEBB COUNTY's Commissioners Court, shall have authority to waive this requirement.

1.2.4 **NOTICE TO PROCEED AND COMMENCEMENT OF CONTRACT TIMES.** Unless otherwise stated on the Notice to Proceed, the Contract Time shall commence to run on the date stated on the Notice to Proceed. No Work shall commence any earlier than the date stated on Notice to Proceed and no Work shall be performed by Contractor or any Subcontractor prior to issuance of the Notice to Proceed. Any work commenced prior to Contractor receiving a Notice to Proceed is performed at Contractor's risk.

1.2.5 **SUBMISSION OF PROJECT SCHEDULE(S).** Prior to commencement of Work (unless otherwise specified elsewhere in the Contract Documents), Contractor shall submit to the Webb County Engineer and Design Consultant or their designee the Project schedule(s), as defined in **Section 3.10** herein, a minimum of five (5) days prior to the Pre-Construction Conference.

1.2.6 **PRE-CONSTRUCTION CONFERENCE.** Before Contractor commences any Work on the Project, a Pre-Construction Conference attended by Contractor, Design Consultant, OWNER'S DESIGNATED REPRESENTATIVE(s) and others, as appropriate, shall be held to establish a working understanding among the Parties as to the Work and discuss, at minimum: the Project Schedule(s) referenced in this **Article 1**; the procedures for handling Shop Drawings and other submittals; the processing of Applications for Payment; and Contractor maintaining required records. The Notice to Proceed may be issued at the Pre-Construction Conference or issued by

WEBB COUNTY at any time at WEBB COUNTY's discretion. Said issuance of the Notice to Proceed shall not be unreasonably withheld by WEBB COUNTY.

1.2.7 Payments for services, goods, work, equipment and materials are contingent upon and subject to the availability and appropriation of funds. In the event funds are not available, appropriated or encumbered to fund a Project, then, at WEBB COUNTY's discretion, this Contract may be terminated immediately with no additional liability to WEBB COUNTY.

### **1.3 CONTRACT DOCUMENTS**

1.3.1 **EXECUTION OF CONTRACT DOCUMENTS.** Execution of the Contract by Contractor is a representation Contractor has been provided unrestricted access to the existing improvements and conditions on the Project Site, Contractor thoroughly has investigated the visible conditions at the Site and the general local conditions affecting the Work and Contractor's investigation was instrumental in preparing its bid or proposal submitted to WEBB COUNTY to perform the Work. Contractor shall not make or be entitled to any claim for any adjustment to the Contract Time or the Contract Sum arising from conditions which Contractor discovered or, in the exercise of reasonable care, should have discovered in Contractor's investigation.

1.3.2 **OWNERSHIP AND USE OF DRAWINGS, SPECIFICATIONS AND OTHER INSTRUMENTS OF SERVICE.** The Drawings, Specifications and other documents, including those in electronic form, prepared by Design Consultant, its Consultants or other Consultants retained by WEBB COUNTY for the Project, which describe the Work to be executed by Contractor (collectively referred to as the "Construction Documents") are and shall remain the property of WEBB COUNTY, whether the Project for which they are made is executed or not. Contractor shall be permitted to retain one record set. Neither Contractor nor any Subcontractor, sub-Subcontractor or material or equipment supplier shall own or claim a copyright in the Drawings, Specifications and other documents prepared by Design Consultant or Design Consultant's Consultants. All copies of Construction Documents, except Contractor's record set, shall be returned or suitably accounted for to Design Consultant on request and upon completion of the Work. The Drawings, Specifications and other documents prepared by Design Consultant and Design Consultant's Consultants, along with copies thereof furnished to Contractor, are for use solely with respect to this Project. The drawings, Specifications or other documents are not to be used by Contractor or any Subcontractor or material or equipment supplier on other projects or for additions to this Project outside the scope of the Work without the specific written consent of WEBB COUNTY. Any such use without written authorization shall be at the sole risk and liability of Contractor. Contractor, Subcontractors and material or equipment suppliers are authorized to use and reproduce applicable portions of the Drawings, Specifications and other documents prepared by the Design Consultant and the Design Consultant's Consultants appropriate to and for use in the execution of their Work under the Contract Documents. All copies made under this authorization shall bear the statutory copyright notice, if any, shown on the Drawings, Specifications and other documents prepared by Design Consultant and Design Consultant's Consultants. Submittal or distribution to meet official regulatory requirements or for other purposes, in connection with this Project, is not to be construed as publication.



- 1321 All of Contractor's non-proprietary, documentary Work product, including reports and correspondence to WEBB COUNTY, prepared pursuant to this Contract, shall be the property of WEBB COUNTY and, upon completion of this Contract and upon written request by WEBB COUNTY, promptly shall be delivered to WEBB COUNTY in a reasonably organized form, without restriction on its future use by WEBB COUNTY. For the avoidance of doubt, documentary Work product does not include privileged communications, proprietary information and documents used to prepare Contractor's Bid Proposal.
- 1322 Contractor may retain for its files any copies of documents it chooses to retain and may use its Work product as it deems fit. Any materially- significant Work product lost or destroyed by Contractor shall be replaced or reproduced at Contractor's non-reimbursable sole cost. In addition, WEBB COUNTY shall have access during normal business hours, during the duration this Contract is in effect and for four (4) years after the final completion of the Work, unless there is an ongoing dispute under the Contract, then such access period shall extend longer until final resolution of the dispute, to all of Contractor's records and documents covering reimbursable expenses, actual base hourly rates, time cards and annual salary escalation records maintained in connection with this Contract for purposes of auditing same at the sole cost of WEBB COUNTY. The purpose of any such audit shall be for the verification of such costs. Contractor shall not be required to keep records of, or provide access to, the makeup of any negotiated and agreed-to lump sums, unit prices or fixed overhead and profit multipliers. Nothing herein shall deny Contractor the right to retain duplicates. Refusal by Contractor to comply with the provisions hereof shall entitle WEBB COUNTY to withhold any payment(s) to Contractor until compliance is obtained.
- 1323 All of Contractor's documentary Work product shall be maintained within Contractor's offices, unless otherwise authorized by WEBB COUNTY. After expiration of this Contract, Contractor's documents may be archived in the Contractor's central record storage facility but shall remain accessible to WEBB COUNTY for the four (4) year period cited in **Section 1.3.22** herein.

**1.3.3 CORRELATION AND INTENT.** The intent of the Contract Documents is to include all items necessary for the proper execution and completion of the Work by Contractor. The Contract Documents are complementary and what is required by one shall be as binding as if required by all. Performance by Contractor shall be required only to the extent consistent with the Contract Documents and which reasonably is inferable from the Contract Documents as deemed necessary to produce the indicated results. In cases of discrepancy between any drawing and the dimension figures written thereon:

- (1) The dimension figures shall govern over scaled dimensions;
- (2) Detailed Drawings and accompanying notations shall govern over general Drawings;

- (3) Specifications shall govern over Drawings, subject to **Section 1.3.3.6** herein;
- (4) Supplemental Conditions shall govern over General Conditions;
- (5) Special Conditions shall govern over Specifications, Drawings and General/Supplemental Conditions; and
- (6) Negotiated Special Conditions shall govern over Special Conditions.

The most recent revision of Plans shall control over older revisions provided same are delivered to Contractor before the Work is commenced on the prior revisions. If Contractor is not provided the most recent and Contractor expended labor and material based on a prior revision, any removal and correction needed to comply with the most recent revision must be pursuant to a Change Order

1331 Organization of the Specifications into divisions, sections, articles, and the arrangement of Drawings shall not control Contractor in dividing the Work among Subcontractors or establishing the extent of Work to be performed by any trade.

1332 Unless otherwise stated in the Contract Documents, words having well-known technical or construction industry meanings are used in the Contract Documents in accordance with such recognized meanings. Where the phrases "directed by", "ordered by" or "to the satisfaction of" WEBB COUNTY, Design Consultant or WEBB COUNTY's Resident Inspector or other specified designation occur, it is understood the directions, orders or instructions to which they relate are those within the scope of and authorized by the Contract Documents.

1333 Reference to manufacturer's instructions, standard specifications, manuals or codes of any technical society, organization or association, laws or regulations of any governmental authority, or to any other documents, whether such reference be specific or by implication, shall mean the latest standard specification, manual, code or laws or regulations in effect at the time of opening of Contractor's Bid Proposal, except as otherwise may be specifically stated or where a particular issue is indicated. Municipal and utility standards shall govern except in case of conflict with the Specifications. In case of a conflict between the Specifications and the referenced standard, the more stringent shall govern.

1334 The most recently issued Document takes precedence over previous issues of the same Document. The order of precedence is as follows, with the highest authority listed herein as "1" and in descending order:

1. Modifications to the Project Contract signed by Contractor, WEBB COUNTY and Design Consultant;
2. Addenda, with those of later date(s) having precedence over those with earlier date(s);

3. Special Conditions;
4. Supplemental Conditions;
4. General Conditions;
5. Special Provisions (Horizontal Projects);
6. Specifications;
7. Drawings;

1335 Should the Drawings and Specifications be inconsistent, contract pricing shall be based on the better quality and greater quantity of work indicated. In the event of the above-mentioned inconsistency, WEBB COUNTY shall determine the resolution of the inconsistency.

1336 In the Drawings and Specifications, where certain products, manufacturer's trade names or catalog numbers are given, such information is given for the sole and express purpose of establishing a standard of function, dimension, appearance and quality of design in harmony with the Work and is not intended for the purpose of limiting competition. Materials or equipment shall not be substituted unless such a substitution has been specifically accepted for use on this Project by WEBB COUNTY and Design Consultant.

1337 When the work is governed by reference to standards, building codes, manufacturer's instructions or other documents, unless otherwise specified, the edition currently in place as of the date of the submission of the bid shall apply.

1338 Requirements of public authorities apply as minimum requirements only and do not supersede more stringent specified requirements.

1339 Special Provisions, if any, shall be issued by WEBB COUNTY directly to Contractor, shall become part of the Project Specifications and shall modify WEBB COUNTY's Standard Specifications.

**1.3.4 CONFLICT RESOLUTION BETWEEN DOCUMENTS.** Contractor and Consultant hereby agree and acknowledge if anything contained in Consultant's prepared Scope/Project Specifications or anything contained in any other document prepared by or on behalf of Consultant and included with the Project documents is in conflict with the Project solicitation documents and/or with these General Conditions for WEBB COUNTY Construction Contracts, the Project solicitation documents and these General Conditions for WEBB COUNTY Construction Contracts shall take precedence and control to resolve said conflict(s).

**1.3.5 INTERPRETATION.** In the interest of brevity, the Contract Documents frequently omit

modifying words such as "all" and "any" and articles such as "the" and "an", but the fact a modifier or an article is absent from one statement and appears in another is not intended to affect the interpretation of either statement.

## ARTICLE II. WEBB COUNTY

### 2.1 GENERAL

2.1.1 WEBB COUNTY, Texas, a political subdivision of the State of Texas with its principal office located at 1000 Houston St., Laredo, Texas and identified as "WEBB COUNTY" or as "Owner" in the Contract and these General Conditions, is referred to throughout the Contract Documents as if singular in number. WEBB COUNTY shall designate in writing to Contractor a representative (hereafter referred to as "OWNER'S DESIGNATED REPRESENTATIVE" or "ODR") who shall have express authority to bind WEBB COUNTY, subject to OWNER's Commissioners Court approval of any change in the work that affects the Contract time or Contract Sum, with respect to all matters concerning this Contract requiring WEBB COUNTY's approval or authorization. Whenever the term "WEBB COUNTY" or "WEBB COUNTY" is found in this Contract or the Contract Documents, such term shall include WEBB COUNTY's agents, elected officials, employees, officers, directors, volunteers, representatives, successors and assigns.

2.1.2 Contractor acknowledges no lien rights exist, with respect to public property.

### 2.2 INFORMATION AND SERVICES TO BE PROVIDED BY WEBB COUNTY

2.2.1 WEBB COUNTY shall provide and maintain the Preliminary Budget and general schedule, if any, for the Project. The Preliminary Budget shall include the anticipated construction cost, contingencies for changes in the Work during construction and other costs that are the responsibility of WEBB COUNTY. The general schedule shall set forth WEBB COUNTY's plan for milestone dates and Substantial Completion and Final Completion of the Project.

2.2.2 WEBB COUNTY shall furnish surveys, if in existence and in WEBB COUNTY's possession, describing physical characteristics, legal limitations and utility locations. The furnishing of these surveys and reports shall not relieve Contractor of any of its duties under the Contract Documents or these General Conditions. Information or services required of WEBB COUNTY by the Contract Documents shall be furnished by WEBB COUNTY with reasonable promptness following actual receipt of a written request from Contractor. It is incumbent upon Contractor to identify, establish and maintain a current schedule of latest dates for submittal and approval by WEBB COUNTY, as required in **Section 3.10** herein, including when such information or services must be delivered. If WEBB COUNTY delivers the information or services to Contractor as scheduled and Contractor is not prepared to accept or act on such information or services, then Contractor shall reimburse WEBB COUNTY for all extra costs incurred by holding, storage, retention or performance, including redeliveries by WEBB COUNTY in order to comply with the current schedule.

2.2.3 Unless otherwise provided in the Contract Documents, Contractor shall be furnished, free of charge, up to three complete sets of the Plans and Specifications by Design Consultant. Additional complete sets of Plans and Specifications, if requested by Contractor, shall be furnished at reproduction cost to Contractor.

2.2.4 WEBB COUNTY's personnel may, but are not required to, be present at the construction site during progress of the Work, along with Design Consultant in the performance of its duties, to verify Contractor's record of the number of workers employed on the Work site, the workers' occupational classification, the time each worker is engaged in the Work and the equipment used by the workers in the performance of the Work, for purpose of verification of Contractor's Applications for Payment and payroll records.

2.2.5 WEBB COUNTY shall reimburse Contractor for the necessary Project-related approvals, fees and required permits with no markup paid to Contractor for these necessary Project-related approvals, fees and required permits costs, unless said costs are stipulated in the Contract Documents as a part of Contractor's cost of Work.

2.2.6 **WEBB COUNTY'S RIGHT TO STOP THE WORK.** If Contractor fails to correct Work reasonably deemed by WEBB COUNTY not in accordance with the requirements of the Contract Documents, as required by **Section 12.3** herein, fails to carry out Work in substantial accordance with the Contract Documents or fails to submit its preliminary schedule(s), bond(s), insurance certificate(s) or any other required submittals, WEBB COUNTY may issue a written order to Contractor to stop the Work, or any portion thereof, until the cause for such order has been eliminated. The right of WEBB COUNTY to stop the Work shall not give rise to any duty on the part of WEBB COUNTY to exercise this right for the benefit of the Contractor or any other person or entity. This right shall be in addition to and not in restriction of WEBB COUNTY's rights pursuant to **Section 12.3** herein. WEBB COUNTY's issuance of an order to Contractor based on the foregoing to stop the Work shall not give rise to any claim by Contractor for additional time, cost or general conditions costs.

2.2.7 **WEBB COUNTY'S RIGHT TO CARRY OUT THE WORK.** If Contractor defaults, neglects or fails to carry out the Work in accordance with the Contract Documents and fails, within a three (3) work-day period after receipt of written notice from WEBB COUNTY, to commence and continue correction of such default, neglect or failure with diligence and promptness, WEBB COUNTY may, without prejudice to other remedies WEBB COUNTY may have, correct such deficiencies, neglect or failure. In such case, an appropriate Change Order may be issued deducting from payments then or thereafter due Contractor reflecting the reasonable cost of correcting such deficiencies, neglect or failure of Contractor, including all of WEBB COUNTY's incurred expenses and compensation for Design Consultant's additional services made necessary by such default, neglect or failure of Contractor. If payments then or thereafter due Contractor are not sufficient to cover such amounts for the Work performed, Contractor shall pay the difference to WEBB COUNTY.

## **ARTICLE III. CONTRACTOR**

### **3.1 GENERAL**

3.1.1 Contractor is the person or entity identified as such in the Contract and is referred to throughout the Contract Documents as if singular in number. The term "Contractor" means the Contractor or the Contractor's authorized representative.

3.1.2 Contractor shall perform the Work in a good and workmanlike manner, except to the extent the Contract Documents expressly specify a higher degree of finish or workmanship.

3.1.3 Contractor shall not be relieved of its obligations, responsibilities or duties to perform the Work in accordance with the Contract Documents, either by any activities or duties of Design Consultant in Design Consultant's administration of the Contract or by tests, inspections or approvals required or performed by WEBB COUNTY or any person other than the Contractor.

### **3.2 REVIEW OF CONTRACT DOCUMENTS AND FIELD CONDITIONS BY CONTRACTOR**

3.2.1 Since the Contract Documents are complementary, before starting each portion of the Work, Contractor carefully shall:

- (1) study and compare the various Drawings and other Contract Documents relative to that portion of the Work and the information furnished by WEBB COUNTY;
- (2) take field measurements of any existing conditions related to that portion of the Work; and
- (3) observe any conditions at the Site affecting the Work.

Any error, inconsistencies or omissions discovered by Contractor shall be promptly reported to WEBB COUNTY via a Request for Information in such form as WEBB COUNTY may require.

3.2.1.1 The exactness of existing grades, elevations, dimensions or locations given on any Drawings issued by Design Consultant, or the work installed by other contractors, is not guaranteed by WEBB COUNTY. Contractor shall, therefore, satisfy itself as to the accuracy of all grades, elevations, dimensions and locations, provided that same are as indicated on the Plans and Specifications.

3.2.1.2 In all cases of interconnection of its Work with existing conditions or with work performed by others, Contractor shall verify at the site all dimensions relating to such existing or other work. Any errors due to Contractor's failure to so verify all such grades, elevations, dimensions or locations shall comply with the Plans and Specification and shall



promptly be rectified by Contractor without any additional cost to WEBB COUNTY.

322 As between WEBB COUNTY and Contractor, and subject to the provisions of **Section 3.2.4** below, Contractor has no responsibility for the timely delivery, completeness, accuracy and/or sufficiency of the Specifications or Drawings (or any errors, omissions, or ambiguities therein), and is not responsible for any failure of the design of the facilities or structures as reflected thereon to be suitable, sound or safe. Contractor shall be deemed to have satisfied itself as to the design contained in and reflected by the Specifications and the Drawings. In particular, but without prejudice to the generality of the foregoing, Contractor shall review the Contract Documents to establish:

- 3.2.2.1 the information is sufficiently complete to perform the Work; and
- 3.2.2.2 there are no obvious or patent ambiguities, inaccuracies or inconsistencies within or between the documents forming the Contract; and
- 3.2.2.3 Contractor shall work with the aforementioned Contract Documents so as to perform the Work and of each and every part thereof to ensure the Work and each and every part thereof shall, jointly and severally, be in accordance with the requirements of the Contract Documents and, in particular but without limiting the generality of the foregoing, the Work as a whole and, as appropriate, each and every part thereof, shall comply with the requirements of any performance Specifications.

323 Any design errors or omissions noted by Contractor during its review shall be reported to WEBB COUNTY, but it is recognized the Contractor's review is made in Contractor's capacity as a contractor and not as a licensed design professional, unless otherwise specifically provided in the Contract Documents. Contractor is not required to ascertain if Contract Documents are in accordance with applicable laws, statutes, ordinances, building codes, and rules and regulations, but any nonconformity discovered by or made known to Contractor promptly shall be reported both to WEBB COUNTY and Design Consultant.

324 If Contractor believes additional cost or time is involved because of clarifications or instructions issued by Design Consultant, in response to the Contractor's Notices or Requests for Information, Contractor shall make Claims as provided in **Section 4.3.5** and **Section 4.3.6** herein. If Contractor fails to perform the obligations of **Section 3.2.1** and **Section 3.2.2** herein, Contractor shall pay such costs and damages to WEBB COUNTY, to include applicable Liquidated Damages, as would have been avoided if Contractor had performed such obligations. Contractor shall not be liable to WEBB COUNTY or Design Consultant for damages resulting from errors, inconsistencies or omissions in the Contract Documents or for differences between field measurements or conditions and the Contract Documents, unless Contractor recognized or should have recognized such obvious error, inconsistency, omission or differences and knowingly failed to report it to WEBB COUNTY and Design Consultant, as required by this **Section 3.2.3**.

### **3.3 SUPERVISION AND CONSTRUCTION PROCEDURES**

331 Contractor shall supervise, inspect, and direct the Work competently and efficiently, exercising the skill and attention of a reasonably prudent Contractor, devoting such attention, and

applying such skills and expertise as may be necessary to perform the Work in accordance with the Contract Documents. Contractor solely shall be responsible for the means, methods, techniques, sequences, procedures, and coordination of all portions of the Work under the Contract, unless the Contract Documents give other specific instructions concerning these matters. If the Contract Documents give specific instructions concerning construction means, methods and/or techniques, Contractor then shall evaluate the jobsite safety thereof and, except as stated herein below, shall be fully and solely responsible for the jobsite's safety of such means, methods, techniques, sequences, or procedures. If, upon its evaluation, Contractor determines such means, methods, techniques, sequences, or procedures may not be safe, Contractor shall give timely written notice to WEBB COUNTY and Design Consultant and Contractor shall not proceed with that portion of the Work without further written instructions from WEBB COUNTY. Sequencing and procedures shall be coordinated and agreed upon by WEBB COUNTY, Design Consultant and Contractor.

332 Contractor shall be responsible to WEBB COUNTY for the acts and omissions of Contractor's agents and employees, Subcontractors and their agents and employees and other persons or entities performing portions of the Work for or on behalf of Contractor or any of its Subcontractors.

333 Contractor shall be responsible for inspection of portions of Work already performed, to determine which such portion are in proper condition to receive subsequent Work.

334 Contractor shall bear responsibility for design and execution of acceptable trenching and shoring procedures, in accordance with Texas Government Code, Section 2166.303 and Texas Health and Safety Code, Subchapter C, Sections 756.021, et seq.

335 It is understood and agreed the relationship of Contractor to WEBB COUNTY shall be of an independent contractor. Nothing contained or inferable in the Contract documents shall be read, deemed, or construed to make Contractor the agent, servant or employee of WEBB COUNTY or create any partnership, joint venture or other association between WEBB COUNTY and Contractor. Any direction or instruction by WEBB COUNTY, in respect of the Work, shall relate to the results WEBB COUNTY desires to obtain from the Work and shall in no way affect Contractor's independent contractor status, as described herein.

336 Contractor shall review Subcontractor(s) written safety programs, procedures, and precautions in connection with performance of the Work. However, Contractor's duties shall not relieve any Subcontractor(s) or any other person or entity (e.g. a supplier), including any person or entity with whom Contractor does not have a contractual relationship, of their responsibility or liability relative to compliance with all applicable federal, state and local laws, rules, regulations and ordinances, which shall include the obligation to provide for the safety of their employees, persons, and property and their requirements to maintain a work environment free of recognized hazards. The foregoing notwithstanding, the requirements of this **Section 3.3.6** are not intended to impose upon Contractor any additional obligations Contractor would not have under any applicable state or federal laws including, but not limited to, any rules, regulations or statutes pertaining to the Occupational Safety and Health Administration.

### 3.4 LABOR AND MATERIALS

3.4.1 Unless otherwise provided in the Contract Documents, Contractor shall provide and pay for all labor, materials, equipment, tools, construction equipment and machinery, water, heat, utilities, transportation and other facilities and services necessary for proper execution and completion of the Work, whether temporary or permanent and whether or not incorporated or to be incorporated in the Work.

3.4.2 **PREVAILING WAGE RATE AND LABOR STANDARD PROVISIONS.** The Provisions of Chapter 2258 of the Texas Government Code expressly are made a part of this Contract. In accordance therewith, a schedule of the general prevailing rate of per diem wages in this locality for each craft or type of worker needed to perform this Contract shall be obtained by Contractor from WEBB COUNTY and included in Contractor's Project bid package, prior to Contractor bidding of the Project and such schedule shall become a part hereof. If no prevailing wage rate of per diem wages has been adopted by Webb County then the parties shall use the wage rate determined by the US Department of Labor in accordance with the Davis-Bacon Act, 40 U.S.C. Section 276a, (which can be accessed on the internet at <https://www.dol.gov/> or <https://beta.sam.gov/>) effective as of the date of this Agreement. The establishment of prevailing wage rates, pursuant to Chapter 2258 of the Texas Government Code, shall not be construed to relieve Contractor from its obligation under any federal or state law, regarding the wages to be paid to or hours worked by laborers, workers, or mechanics, insofar as applicable to the work to be performed hereunder. Contractor, in the execution of this Project, agrees it shall not discriminate in its employment practices against any person because of race, color, creed, sex, or origin. Contractor agrees it shall not engage in employment practices which have the effect of discriminating against employees or prospective employees because of race, color, creed, national origin, sex, age, handicap or political belief or affiliation. This Contract provision shall be included in its entirety in all Subcontractor agreements entered into by the Contractor or any Subcontractor employed on the project.

### 3.4.3 SUBSTITUTIONS

3.4.3.1 Contractor's proposed substitutions and alternates may be rejected by WEBB COUNTY without explanation and shall be considered by WEBB COUNTY only under one or more of the following conditions:

- (a) the proposal is required for compliance with interpretation of code requirements or insurance regulations then existing;
- (b) specified products are unavailable through no fault of Contractor; and
- (c) when, in the judgment of WEBB COUNTY or Design Consultant, a substitution substantially would be in WEBB COUNTY's best interests in terms of cost, time or other considerations.

3.4.3.2 Contractor shall submit to WEBB COUNTY and Design Consultant:

- (a) a full explanation of the proposed substitution and submittal of all supporting data, including technical information, catalog cuts, warranties, test results, installation instructions, operating procedures and other like information necessary for a complete evaluation of the substitution;
- (b) a written explanation of the reasons the substitution is necessary, including the benefits to WEBB COUNTY and to the Work, in the event the substitution is acceptable to WEBB COUNTY;
- (c) the adjustment, if any, in the Contract Sum;
- (d) the adjustment, if any, in the time of completion of the Contract and the construction schedule; and
- (e) in the event of a substitution under Section 3.4.3.1 herein, an affidavit stating:
  - (1) Contractor's proposed substitution conforms to and meets all the requirements of the pertinent Specifications and requirements shown on the Drawings; and
  - (2) Contractor accepts the warranty and correction obligations in connection with the proposed substitution as if originally specified by Design Consultant.

Proposals for substitutions shall be submitted to Design Consultant in sufficient time to allow Design Consultant no less than fourteen (14) calendar days for review. No substitutions shall be considered or allowed without Contractor's submittal of complete substantiating data and information as stated hereinbefore.

**3.4.3.3** In the event of a substitution submittal under this **Section 3.4.3**, and whether or not any such proposed substitution is accepted by WEBB COUNTY or Design Consultant, Contractor shall reimburse WEBB COUNTY, at WEBB COUNTY's reasonable discretion, for any fees incurred and charged by Design Consultant or other Consultants for evaluating each proposed substitute.

**3.4.3.4** Except as otherwise stipulated in the Contract Documents or required for safety or protection of persons or the Work or property at the Site or adjacent thereto, no Work shall be allowed by WEBB COUNTY between the hours of 10:00 p.m. and 6:00 a.m. of the following calendar day, unless directed by the ODR or requested in writing by Contractor and approved by WEBB COUNTY.

**344** Contractor shall, at all times, enforce strict discipline and good order among persons working on the Project and shall not employ or continue to employ any unfit person on the Project or any person not skilled in the assigned work. Contractor shall be liable for and responsible to WEBB COUNTY for all acts and omissions of its employees, all tiers of its Subcontractors,

material suppliers, anyone who Contractor may allow to perform any Work on the Project and their respective officers, agents, employees, and Consultants who Contractor may allow to come on the job site, with the exception of WEBB COUNTY or WEBB COUNTY's Designee. WEBB COUNTY, at any time, for any reason or for no reason, may direct Contractor to remove any employee, Subcontractor, material supplier or anyone else from the Project and Contractor promptly shall comply with WEBB COUNTY's direction. In addition, if Contractor receives written notice from WEBB COUNTY complaining about any Subcontractor, employee or anyone who is a material hindrance that substantially interferes with or causes an unsafe workplace, or the proper or timely execution of the Work, Contractor shall remedy such complaint without delay to the Project and at no additional cost to WEBB COUNTY. This provision shall be included in all contracts between Contractor and all Subcontractors of all tiers.

345 Contractor recognizes, accepts and hereby acknowledges the Project Site is a public facility representing WEBB COUNTY. As such, Contractor shall prohibit the possession or use of alcohol, controlled substances, and any prohibited weapons on the Project Site and shall require appropriate dress of Contractor's forces consistent with the nature of the Work being performed, including the wearing of shirts at all times. Harassment of any kind, including sexual harassment, of employees of Contractor or any Subcontractor, employees or Consultants of WEBB COUNTY or of any visitor to the Project site, by Contractor, employee(s) of Contractor, a Subcontractor or an employee of Subcontractor is strictly forbidden. Any person, Contractor, employee of Contractor, Subcontractor or employee of Subcontractor who is found to have engaged in such conduct shall be subject to appropriate disciplinary action by Contractor and/or WEBB COUNTY, including the removal and of the violating person(s) or employee(s) of Contractor or Subcontractor from the Project Site; removal or exclusion of a violating person(s) shall only be effectuated after consultation with representatives of WEBB COUNTY, the Contractor and the violating person(s) and, if WEBB COUNTY so elects, termination from the Project.

346 Contractor only shall employ or use labor in connection with the Work capable of working harmoniously with all trades, crafts and any other individuals associated with the Project.

347 All materials and installed equipment shall be as specified in the Contract Documents and, if not so specified, shall be new and of good quality, except as otherwise provided in the Contract Documents. If required by WEBB COUNTY or Design Consultant, Contractor shall furnish satisfactory evidence (including reports of required tests) as to the source, kind and quality of materials and equipment installed. Contractor may make substitutions only with the consent of WEBB COUNTY, after Contractor's compliance with **Section 3.4.3** herein.

348 All materials shall be shipped, stored, and handled in a manner which shall protect and ensure their condition at the time of incorporation in the Work. After installation, all materials shall be properly protected against damage to ensure they are in the condition as required by **Section 3.5.1** herein when the Work is Substantially Completed or WEBB COUNTY takes over use and occupancy, whichever is earlier.

349 Contractor shall procure and furnish to WEBB COUNTY all guarantees, warranties, spares and maintenance manuals called for by the Specifications or which normally are provided by a manufacturer. The maintenance manual shall include a catalog for any equipment, materials,

supplies, or parts used in the inspection, calibration, maintenance or repair of the equipment and items in the catalog shall be readily available for purchase, provided that same are available to Contractor.

3410 During construction of the Work and for ten (10) years after final completion or longer if, during the duration of this Contract or during the ten (10) years after the final completion of the Work, a dispute between any parties to this Project exists, Contractor shall retain and shall require all Subcontractors to retain for inspection and audit by WEBB COUNTY all books, accounts, reports, files, time cards, material invoices, payrolls and evidence of all other direct or indirect costs related to the bidding and performance of this Work (hereinafter referred to "stored documents"). Upon request by WEBB COUNTY, a legible copy or the original of any or all such records shall be produced by Contractor at the administrative office of WEBB COUNTY. To the extent it requests copies of such documents, WEBB COUNTY shall reimburse Contractor and its Subcontractors for copying costs. Contractor shall not be required to keep records of or provide access to the makeup of any negotiated and agreed-to lump sums, unit prices or fixed overhead and profit multipliers. In lieu of the foregoing, Contractor may elect to deliver to WEBB COUNTY the Stored Documents or certified copies of same in fulfillment of these requirements.

### **3.5 WARRANTY**

351 Contractor warrants materials and equipment furnished and installed under the Contract shall be new and of good quality, unless otherwise required or permitted by the Contract Documents, the Work shall be free from defects not inherent in the quality required or permitted and the Work shall conform to the requirements of the Contract Documents. Work not conforming to this warranty and these requirements, including substitutions not properly approved and authorized by WEBB COUNTY, may be considered "defective (this is the definition of "defective applied in the Contract Documents"). Contractor's warranty excludes remedy for damage or defect caused by abuse, Acts of God, Acts of Man (not associated with Contractor), shifting ground, water tables, floods, riots, failure of material as specified in the Contract Documents, modifications not executed by the Contractor, improper or insufficient maintenance, improper operation, normal wear and tear and normal usage, and additional damage or defects caused by WEBB COUNTY's failure to promptly notify Contractor. If required by WEBB COUNTY, Contractor shall furnish satisfactory evidence as to the kind and quality of materials and equipment.

352 A right of action by WEBB COUNTY for any breach of Contractor's express warranty herein shall be in addition to, and not in lieu of, any other remedies WEBB COUNTY may have under this Contract at law or in equity, regarding any defective Work but as limited in the Contract Documents.

353 The warranty provided in Section 3.5.1 herein shall be in addition to and not in limitation of any other warranty or remedy required by law or by the Contract Documents. After Substantial Completion, such warranty is replaced with Contractor's one (1) year warranty against defective workmanship and/or defective materials, it being deemed that at Substantial Completion Contractor complied with the Work's Plans and Specification. During the post Substantial Completion warranty period, upon written timely demand by WEBB COUNTY to Contractor to replace defective workmanship and/or materials and re-execute any such defective Work disclosed



to the Contractor by WEBB COUNTY within a period of one (1) year after Substantial Completion of the applicable Work, within one (1) year after discovery or by the exercise of due diligence should have been discovered by WEBB COUNTY. Latent Defects are limited to being discovered within the one (1) year period and if not, same are not warranted.

354 All warranties shall be assignable to WEBB COUNTY. Submittal of all warranties and guarantees are required as a prerequisite to the final payment.

355 Except when a longer warranty time is specifically called for in the Specifications or is otherwise provided by law or by manufacturer, all warranties shall be for twelve (12) months and shall be in form and content otherwise reasonably satisfactory to WEBB COUNTY. WEBB COUNTY and Contractor acknowledge the Project may involve construction work on more than one (1) building or section of infrastructure of WEBB COUNTY's. While the overall Project shall have a single date for Substantial Completion of the Work and Final Completion of the Work, each building, section of infrastructure or approved phase of each section of infrastructure may have its own separate and independent date of Substantial Completion or Final Completion.

356 If separate dates for Substantial Completion and Final Completion are established and granted by WEBB COUNTY, at WEBB COUNTY's sole discretion and as a result of WEBB COUNTY electing partially to occupy areas prior to the Project's overall date for Substantial Completion, Contractor shall maintain a complete and accurate schedule of the dates of Substantial Completion and, if WEBB COUNTY accepts partial occupancy of those completed areas, the dates upon which the one (1) year warranty on each building, phase or section of infrastructure granted Substantial Completion shall expire. If separate dates are granted, Contractor agrees to provide notice of the warranty expiration date(s) to WEBB COUNTY and Design Consultant at least one (1) month prior to the expiration of the one (1) year warranty period on each building, section of infrastructure or each phase of the section of infrastructure which has achieved Substantial Completion.

357 Prior to termination of any one (1) year warranty period, Contractor shall accompany WEBB COUNTY and Design Consultant on re-inspection of the building, section of infrastructure or phase of the section of infrastructure and be responsible for correcting any reasonable additional deficiencies not caused by WEBB COUNTY or by the use of the building, section of infrastructure or phase of the section of infrastructure observed and/or reported during the re-inspection. However, Contractor will not be responsible for any matter excluded from warranty as stated in 3.5.1 above.

358 For extended warranties required by the Contract Documents, WEBB COUNTY shall notify Contractor of deficiencies which are included and not excluded under the Warranty under paragraph 3.5.1 above. Contractor shall start remedying these defects within seven (7) calendar days of initial notification from WEBB COUNTY. Contractor shall prosecute the work without interruption until accepted by WEBB COUNTY and Design Consultant, even though such prosecution may extend beyond the limit of the warranty period. If Contractor fails to provide notice of the expiration of the one (1) year warranty period at least one (1) month prior to the expiration date and conduct the required walk through with WEBB COUNTY, Contractor's warranty obligations described in this **Section 3.5.5** shall continue until such inspection is

conducted and any deficiencies found in the inspection is corrected. However, such obligations are binding on Contractor only if it can be proven that the deficiencies occurred prior to the end of the one (1) warranty period.

359 Warranties shall become effective on a date established by WEBB COUNTY in accordance with the Contract Documents. This date shall be the date of Substantial Completion of the entire Work, unless otherwise provided in any Certificate of Partial Substantial Completion approved by the Parties, except for Work to be completed or corrected after the date of Substantial Completion and prior to final payment and those occurrences addressed in **Section 3.5.3** herein. Warranties for Work to be completed or corrected after the date of Substantial Completion and prior to Final Completion shall become effective on the later of the date the Work is completed or corrected and accepted by WEBB COUNTY and Design Consultant or the date of final completion of the Work.

35.10 Neither final payment nor compliance by Contractor with any provision in the Contract Documents shall constitute an acceptance of Work not done in accordance with the Contract Documents or relieve Contractor or its sureties of liability, with respect to any warranties or responsibility for faulty materials and workmanship. Contractor warrants all Work shall conform to the requirements of the Contract Documents. Non-acceptance must be based on material non-compliance with the Contract Documents.

35.11 Contractor agrees to assign to WEBB COUNTY, at the time of Final Completion of the Work, any and all manufacturer's warranties relating to materials and labor used in the Work and further agrees to perform the Work in such manner so as to preserve any and all such manufacturer's warranties, provided such assignment shall contain a reservation of Contractor's right also to enforce the manufacturer's warranties. As a condition precedent to final payment, Contractor shall prepare a notebook with reference tabs and submit three (3) copies of the notebook to WEBB COUNTY which shall include a complete set of warranties from Subcontractors, manufacturers or suppliers, as appropriate, and executed by and between Contractor and WEBB COUNTY, as required under this Contract, with a specified warranty commencement date, as required by the Contract Documents. Copies of the complete set of warranties from Subcontractors, manufacturers and/or suppliers, as appropriate, executed by Contractor as required by the Contract Documents, with and between WEBB COUNTY and Contractor. A specified warranty commencement date, as required by the Contract Documents, also shall be submitted to WEBB COUNTY in an electronic format (PDF) on a Compact Disc (CD).

### **3.6 TAXES.**

Contractor shall not include in the Contract Sum or any modification thereto any amount for sales, use or similar taxes for which WEBB COUNTY is exempt. Upon request by Contractor, WEBB COUNTY shall provide Contractor with a tax exemption certificate or other documentation necessary to establish WEBB COUNTY's exemption from such taxes.

### **3.7 PERMITS, FEES AND NOTICES**

37.1 **PERMITS.** Unless otherwise provided in the Contract Documents or by WEBB COUNTY, as per **Section 2.2.5** herein, it is the responsibility of and Contractor shall secure all

permits, licenses and inspections. WEBB COUNTY and Design Consultant may assist Contractor, when necessary, in obtaining such permits, licenses and inspections necessary for the proper execution and completion of the Work. For federally funded construction projects, when applicable, WEBB COUNTY shall prepare and submit the necessary paperwork to satisfy Texas Pollutant Discharge Elimination System (hereafter referred to as "TPDES"), regulations of the Texas Commission on Environmental Quality.

372 Contractor shall comply with and give all notices required by law, ordinance, rule, regulations, and lawful orders of public authorities applicable to performance of the Work.

373 It is not Contractor's responsibility to ascertain the Contract Documents are in accordance with applicable laws, statutes, ordinances, building codes and rules and regulations. However, if Contractor observes portions of the Contract Documents are at variance therewith, Contractor promptly shall notify WEBB COUNTY and Design Consultant in writing of any variances and all necessary changes shall be accomplished by appropriate modification(s) before Contractor performs any Work affected by such modification(s).

374 If Contractor performs Work knowing Work is contrary to laws, statutes, ordinances, building codes and rules and regulations, without such notice to and approval from WEBB COUNTY and Design Consultant, Contractor shall assume sole responsibility for performing such Work and shall bear all costs attributable to correct such Work.

375 Contractor also shall assist WEBB COUNTY in obtaining all permits and approvals and, at WEBB COUNTY's request, pay all fees and expenses, if any, associated with TPDES regulations of the Texas Commission on Environmental Quality, as well as local authorities, if applicable, which require completion of documentation and/or acquisition of a "Land Disturbing Activities Permit" for a Project. Contractor's obligations under this paragraph do not require it to perform engineering services during the pre-construction phase to prepare proper drainage for the Project Site. However, any drainage alterations made by Contractor during the construction process, which require the issuance of a permit, shall be at Contractor's sole cost. It shall be Contractor's responsibility to prepare and submit the permit approval documentation provided by the regulatory agencies prior to beginning any Work.

### **3.8 ALLOWANCES**

381 Contractor shall include in the Contract Sum all allowances stated in the Contract Documents. Items covered by allowances shall be supplied for such amounts and by such persons or entities as WEBB COUNTY may direct, but Contractor shall not be required to employ persons or entities to whom Contractor has reasonable objection.

382 Unless otherwise provided in the Contract Documents:

3.8.2.1 Allowances shall cover the cost to Contractor of materials and equipment delivered at the site and all required taxes, less applicable trade discounts;

3.8.2.2 Contractor's costs for unloading and handling at the site, labor, installation costs, overhead, profit and other expenses, contemplated for stated allowance, shall be

included in the allowances;

- 3.8.2.3 Whenever actual costs are more than or less than allowances, the Contract Sum shall be adjusted accordingly by Change Order. The amount of the Change Order shall reflect both the difference between actual costs and the allowances under **Section 3.8.2.1** herein and all changes in Contractor's costs under **Section 3.8.2.2** herein.

383 Materials and equipment under an allowance shall be selected by WEBB COUNTY within such time as is reasonably specified by Contractor as necessary to avoid any delay in the Work.

### **3.9 SUPERINTENDENT/KEY PERSONNEL**

391 At all times during the progress of the Work, Contractor shall assign a competent resident superintendent who is able to communicate fluently in English, along with any necessary assistant(s) who is/are satisfactory to WEBB COUNTY. Any superintendent designee shall be identified in writing to WEBB COUNTY promptly after WEBB COUNTY issues written Notice to Proceed. The superintendent shall represent Contractor at all time and all directions given to the superintendent shall be binding on Contractor. The designated superintendent shall not be replaced without written notice to and the approval of WEBB COUNTY, which approval shall not be unreasonably withheld, except with good reason (including any termination or disability of the superintendent) or under extraordinary circumstances. The superintendent may not be employed on any other project prior to Final Completion of the Work without the approval of WEBB COUNTY, which approval shall not be unreasonably withheld.

392 Contractor shall furnish a list to Design Consultant and WEBB COUNTY of all Architects, Engineers, Consultants, Sub-Consultants, job-site superintendents, Subcontractors, and suppliers involved in the Project construction. Design Consultant also shall provide said information to WEBB COUNTY.

- 3.9.2.1 WEBB COUNTY, upon the showing of good and reasonable cause, may reject or require removal of any Architect, Engineer, Consultant, Sub-Consultant, job superintendent, employee of the Contractor, Subcontractor, or sub- Subcontractor and/or supplier involved in the Project.

- 3.9.2.2 Contractor shall provide an adequate staff for the proper coordination and expedition of the Work.

- 3.9.2.3 WEBB COUNTY reserves the right to utilize one or more of its employees or Consultants to function in the capacity of WEBB COUNTY's Inspector, whose primary function shall be daily inspections, checking pay requests or construction timelines and the verification of the storage of supplies and materials.

- 3.9.2.4 Contractor shall not change any key personnel or key Subcontractors without the prior written consent of WEBB COUNTY, which consent shall not be unreasonably

withheld. In the event key personnel leaves Contractor's employment, such key personnel's replacement shall be subject to WEBB COUNTY's reasonable approval.

### **3.10 CONTRACTOR'S PROJECT SCHEDULES**

**3.10.1 PROJECT SCHEDULE METHOD.** Contractor shall create and maintain a Critical Path Method (hereafter referred to as "CPM") Project Schedule, showing the manner of execution of Work which Contractor intends to follow, in order to complete the Project within the allotted time. The Project Schedule shall employ CPM for the planning, scheduling, and reporting of Work, as described in this **Section 3.10**. Contractor shall create and maintain the Project Schedule. The observance of the requirements herein is an essential part of the Work to be performed under the Contract.

**3.10.2 SCHEDULING PERSONNEL.** Unless otherwise indicated in writing by WEBB COUNTY, Contractor shall provide an individual, who shall be referred to hereafter as "Scheduler", to create and maintain the Project Schedule. Scheduler shall be proficient in CPM analysis, possess sufficient experience to be able to perform required tasks and able to prepare and interpret reports. Scheduler shall be made available for discussion or meetings when requested by WEBB COUNTY.

### **3.10.3 PROJECT SCHEDULE SUBMISSION**

**3.10.3.1** Unless indicated otherwise, Contractor shall submit Project Schedule(s) for the Work in relation to the entire Project to WEBB COUNTY and Design Consultant at least three (3) calendar days prior to the pre-construction conference.

**3.10.3.2** All Project Schedule submittals shall be in the electronic form to include PDF plots of the schedule, a PDF plot defining the Critical Path and two week look-ahead, and include the native compatible scheduling file format. Contractor shall submit the schedule to WEBB COUNTY and Design Consultant via electronic mail, CD-Rom or any other electronic format acceptable to WEBB COUNTY.

**3.10.3.3** This initial schedule shall indicate the dates for starting and completing the various aspects/phases required to complete the Work, including mobilization, procurement, installation, testing, inspection, and acceptance of all the Work of the Contract, including any contractually mandated milestone dates. The Project Schedule shall not exceed the time limits set forth in the Contract Documents. Contractor shall organize the Project Schedule and provide adequate detail, so the Schedule is capable of measuring and forecasting the effect of delaying events on completed and uncompleted activities.

**3.10.3.4** The Project Schedule shall show the order in which Contractor proposes to carry out the Work in accordance with the final approved phasing plan, if any, and the anticipated start and completion dates of each phase of the Work. The Project Schedule shall be in the form of a time scaled work progress chart, to indicate the

percentage of Work scheduled for completion at various critical milestones.

3.10.3.5 Contractor shall maintain a schedule of Shop Drawings and Sample Submittals, and each submitted Shop Drawing and Sample Submittal shall list each required submittal and the expected time(s) for submitting, reviewing, and processing such submittal.

3.10.3.6 WEBB COUNTY shall review the Project Schedule within fifteen (15) calendar days for compliance with the Specifications and notify Contractor of its acceptability.

**3.104 PROJECT SCHEDULE SEQUENCING.** The Project Schedule shall show the sequence and interdependence of activities required for complete performance of the Work. Contractor shall be responsible for assuring all Work sequences are logical and show a coordinated plan of Work in accordance with the sequence of work outlined in the Plans. The purpose of WEBB COUNTY requiring the Project Schedule shall be to:

3.10.4.1 Ensure adequate planning during the execution and progress of the Work in accordance with the allowable number of calendar days and all milestones;

3.10.4.2 Assure coordination of the efforts of Contractor, WEBB COUNTY, utilities and others that may be involved in the Project and those activities are included in the Schedule highlighting coordination points with others;

3.10.4.3 Assist Contractor and WEBB COUNTY in monitoring the progress of the Work and evaluating proposed changes to the Contract; and

3.10.4.4 Assist WEBB COUNTY in administering the Contract time requirements.

**3.105 PROJECT SCHEDULE ACTIVITIES.** Contractor shall provide WEBB COUNTY a legend for all abbreviations used. The activities shall be coded so organized plots of the Project Schedule may be produced. Typical activity coding includes traffic control phase, location, and work type. Contractor shall show an estimated production rate per working day for each Work activity. Activity durations shall be based on production rates shown. Each activity on the Project Schedule shall include:

3.10.5.1 An activity number utilizing an alphanumeric designation system agreeable to WEBB COUNTY;

3.10.5.2 A concise description of the Work represented by the activity; and

3.10.5.3 Activity durations in whole work days, with a maximum of twenty (20) work days. Durations greater than twenty (20) work days may be used for non-construction activities (mobilization, submittal preparation, curing, etc.), and other activities mutually agreeable between WEBB COUNTY and Contractor.



### 3.106 PROJECT SCHEDULE WORK DURATION AND RESOURCES

3.10.6.1 The Project Schedule layout shall be grouped by Project and then by Work Breakdown Structure (hereafter referred to as "WBS") for organizational purposes.

3.10.6.2 The original and remaining Work duration shall be displayed. The grouping band shall, by default, report Work days planned. One additional level of effort activity shall be added to the schedule as a "time calculator" with a seven (7) day calendar without holidays reflected. The calculation of days should be reflected in the appropriate duration columns.

3.10.6.3 Pursuant to the definitions in **Section 1.1.12** herein, if Contractor's Project does not affect WEBB COUNTY traffic, a determination made solely by WEBB COUNTY on a project-by-project basis, Work shall be scheduled based upon Contractor's five (5) day work week, utilizing the appropriate calendar assignments and using compatible Project Scheduling software. If Contractor's Project affects WEBB COUNTY traffic, a determination made solely by WEBB COUNTY on a project-by-project basis, Work shall be scheduled upon Contractor's six (6) day work week, utilizing the appropriate calendar assignments and using compatible Project Scheduling software.

3.10.6.4 Assign working calendars for the days Contractor plans to work. Contractor shall designate all twelve (12) WEBB COUNTY holidays as non-working days (holidays). For dates beyond the then-current calendar year, Contractor shall assume WEBB COUNTY holidays are the same as the current calendar year.

3.10.6.5 Seasonal weather conditions shall be considered and included in the Project Schedule for all work influenced by temperature and/or precipitation. Seasonal weather conditions shall be determined by an assessment of average historical climatic conditions. Average historical weather data is available through the National Oceanic and Atmospheric Administration (hereafter referred to as "NOAA"). These effects shall be simulated through the use of work calendars for each major work type (i.e., earthwork, concrete paving, structures, asphalt, drainage, etc.). Project and work calendars should be updated each month to show days actually able to work on the various work activities.

3.10.6.6 Only WEBB COUNTY responsible delays in activities affecting milestone dates or the Contract completion date, as determined by CPM analysis, shall be considered for a time extension.

#### 3.10.7 PROJECT SCHEDULE - OTHER REQUIREMENTS. The Project Schedule shall:

3.10.7.1 have all Work coded and organized by WBS. An example of an acceptable WBS shall be provided, upon written request, by WEBB COUNTY to Contractor;

3.10.7.2 reflect Duration Percent complete as the percent complete type;

3.10.7.3 reflect Fixed Units as the duration type;

3.10.7.4 include submittals with a logical tie to what each drives;

- 3.10.7.5 add proposed Change Order(s) and those Change Order(s) shall be reflected on the Schedule as proposed Change Order(s). This task shall be linked to the schedule with logical ties and approved by WEBB COUNTY. Upon approval of a Change Order, a task shall be renamed and shall identify Work performed and Change Order number and resources shall be added to the task;
- 3.10.7.6 only have constraints in accordance with the Plans;
- 3.10.7.7 include activity milestones for material delivery;
- 3.10.7.8 allow default progress; and
- 3.10.7.9 include a detailed explanation in the Project narrative, if Work is performed out of sequence.

### **3.10.8 PROJECT SCHEDULE JOINT REVIEW AND ACCEPTANCE**

3.10.81 The Project Schedule and successive updates or revisions thereof are for Contractor's use in managing the Work. The Project Schedule is for the information of WEBB COUNTY and to demonstrate Contractor has complied with requirements for planning the Work. WEBB COUNTY's acceptance of a Schedule, Schedule update(s) or revisions constitutes WEBB COUNTY's agreement to coordinate its own activities with Contractor's activities, as shown on the schedule.

3.10.82 Within fifteen (15) calendar days of receipt of Contractor's proposed Project Schedule, WEBB COUNTY shall evaluate the Schedule for compliance with this specification and notify Contractor of its findings. If WEBB COUNTY requests a revision or justification, Contractor shall provide satisfaction to WEBB COUNTY within seven (7) calendar days. If Contractor submits a Project Schedule for acceptance, based on a sequence of work not shown in the Plans, Contractor shall notify WEBB COUNTY in writing of said sequence of work, separate from the Schedule submittal.

3.10.83 WEBB COUNTY's review and acceptance of Contractor's Project Schedule only is for conformance to the requirements of the Contract Documents. Review and acceptance by WEBB COUNTY of Contractor's Project Schedule does not relieve Contractor of any of its responsibility for the Project Schedule, Contractor's ability to meet interim milestone dates (if so specified) or meeting the Contract completion date, nor does such review and acceptance expressly or by implication warrant, acknowledge or admit the reasonableness of the logic, durations, manpower or equipment loading of Contractor's Project Schedule. In the event Contractor fails to define any element of Work, activity or logic and WEBB COUNTY's review does not detect this omission or error, such omission or error, whether or when discovered by Contractor or WEBB COUNTY, shall be corrected by Contractor at the next monthly schedule update and shall not affect the Project or Contract completion date.

3.10.84 Acceptance of the Project Schedule, or update and/or revision thereto, does not indicate any approval of Contractor's proposed sequences and duration.

3.10.85 Acceptance by WEBB COUNTY of the Project Schedule or updated Project

Schedule which exceeds contractual time does not alleviate Contractor from meeting the contractual completion date.

31086 Acceptance of a Project Schedule update or revision indicating early or late completion does not constitute WEBB COUNTY's consent to any changes, alter the terms of the Contract, waive either Contractor's responsibility for timely completion, or waive WEBB COUNTY's right to damages for Contractor's failure to do so.

31087 Contractor's scheduled dates for completion of any activity or of the entire Work do not constitute a change in terms of the Contract. Change Orders are the only method of modifying the completion date(s) and Contract time.

31088 Submittal of a schedule, schedule revision or schedule update constitutes Contractor's representation to WEBB COUNTY, as of the date of the submittal, of the accurate depiction of all progress to date and Contractor shall follow the schedule as submitted in performing the Work.

### **3.10.9 PROJECT SCHEDULE UPDATES AND REVISIONS**

31091 The Project Schedule shall be updated monthly, at a minimum, to reflect progress to date and current plans for completing the Work. A paper and an electronic copy of the update shall be submitted to WEBB COUNTY and Design Consultant as directed. WEBB COUNTY has no duty to make progress payments to Contractor unless Contractor's payment application accompanied by the updated Project Schedule. The anticipated date of Substantial Completion shall show all extensions of time granted through Change Order(s) as of the date of the update.

31092 The Project Schedule update shall be submitted no later than the date the pay application is submitted.

31093 Contractor shall meet with WEBB COUNTY each month, at a scheduled Project Schedule update meeting, to review actual progress made through the data date of the schedule update, as determined by WEBB COUNTY. The review of progress shall include dates of activities actually started and/or completed, the percentage of Work completed, the remaining duration of each activity started and/or completed and the amount of Work still to complete, with an analysis of the relationship between the remaining duration of the activity and the quantity of material to install over that given period of time with a citation of past productivity.

31094 The monthly Schedule Update shall include a progress narrative, explaining the Project's progress, identifying all progress made out of sequence, defining the Critical Path, identification of any potential delays, and other relevant data. A Project Schedule Narrative template shall be required for the narrative. Upon request, WEBB COUNTY shall supply said template to Contractor.

31095 Each Schedule shall segregate the Work into a sufficient number of activities to facilitate the efficient use of critical path method scheduling by Contractor, WEBB COUNTY and Design Consultant. The Project Schedule layout shall be grouped first by Project then by WBS. The layout shall include the following columns:

- (1) Activity ID
- (2) Activity Description
- (3) Original Durations
- (4) Remaining Durations
- (5) Early Start and Early Finish Dates
- (6) Late Start and Late Finish Dates
- (7) Total Float
- (8) Performance Percent Complete
- (9) Display logic and target bars in the Gantt bar chart view

31096 Each schedule shall include activities representing manufacturing, fabrication or ordering lead time for materials, equipment or other items for which Design Consultant is required to review submittals, shop drawings, product data or samples.

31097 Each schedule, other than the initial schedule, shall:

- (1) indicate the activities, or portions thereof, which have been completed;
- (2) reflect the actual time for completion of such activities; and
- (3) reflect any changes to the sequence or planned duration of all activities.

31098 If any updated schedule exceeds the time limits set forth in the Contract Documents for Substantial Completion of the Work, Contractor shall include, along with its updated schedule, a statement of the reasons for the anticipated delay in achieving Substantial Completion of the Work and Contractor's planned course of action for completing the Work within the time limits set forth in the Contract Documents. If Contractor asserts the failure of WEBB COUNTY or Design Consultant to provide requested and required information to Contractor as the reason for anticipated delay in completion, Contractor also shall specify what information has been requested and is required from WEBB COUNTY or Design Consultant.

31099 Neither WEBB COUNTY nor Contractor shall have exclusive ownership of float time in the schedule and all float time shall inure to the benefit of the Project.

3109.10 Submission of any schedule under this Contract constitutes a representation by Contractor, as of the date of the submittal:

- (1) the schedule represents the sequence in which Contractor intends to prosecute the remaining Work;

- (2) the schedule represents the actual sequence and duration used to prosecute the completed Work;
- (3) to the best of its knowledge and belief, Contractor is able to complete the remaining Work in the sequence and time indicated; and
- (4) Contractor intends to complete the remaining work in the sequence and time indicated.

3.10.9.11 If Contractor desires to make major changes in the Project Schedule, Contractor shall notify WEBB COUNTY in writing and submit the proposed schedule revision. The written notification shall include the reason for the proposed revision, what the revision is composed of and how the revision was incorporated into the schedule. Major changes are hereby defined as those affecting compliance with the contract requirements and/or those that change the Project's critical path. All other changes may be accomplished through the monthly updating process without written notification.

### **3.10.10 COMPLETION OF WORK**

3.10.10.1 Contractor is accountable for substantially completing the Work in the Contract Time or as otherwise amended by Change Order.

3.10.10.2 If, in the sole judgment of WEBB COUNTY, the Schedule update reflects Work is behind schedule and the rate of performance of Work is inadequate to regain scheduled progress to insure Contractor achieving any Project Milestones (including, but not limited to, Substantial Completion) in accordance with the Project Schedule, WEBB COUNTY may, at its sole option, give written notice to Contractor and direct Contractor, at Contractor's sole expense, to propose and adopt a plan to accelerate the Work so the Work conforms to the Project Schedule and Project Milestones previously agreed upon. Contractor may, but is not limited to, propose:

- (1) increasing Project work forces;
- (2) increasing Project equipment or tools;
- (3) increasing the hours of work or number of shifts per day;
- (4) expediting the delivery of Project materials;
- (5) changing, with the approval of WEBB COUNTY, the schedule logic and Work sequences; or
- (6) taking some other action as Contractor may propose, if acceptable to WEBB COUNTY.

3.10.10.3 Within ten (10) calendar days after such notice from WEBB COUNTY, Contractor shall notify WEBB COUNTY in writing of the specific measures taken and/or planned to be taken to increase the rate of progress of Work on the Project. Contractor shall include an estimate as to the date of scheduled full progress recovery and an updated Project Schedule, illustrating Contractor's plan for achieving timely completion of the Project Milestone's and

the Project's Substantial Completion.

3.10.104 Should WEBB COUNTY deem Contractor's plan of action inadequate to achieve the desired acceleration to bring the Work back on the Project Schedule and achieve Substantial Completion on time, WEBB COUNTY shall have the right to order Contractor, at Contractor's sole expense, to take any corrective measures WEBB COUNTY deems necessary to expedite the progress of Work including, without limitations:

- (1) increasing work forces and hours, to include Contractor working additional shifts of overtime;
- (2) supplying additional manpower, equipment and facilities;
- (3) re-sequencing the Work;
- (4) expediting the fabrication and supply of materials; and/or
- (5) other similar measures WEBB COUNTY may direct (hereafter (1) - (5) herein above collectively referred to as "Extraordinary Measures").

Such Extraordinary Measures WEBB COUNTY directs shall continue until the progress of the Work complies with the Milestone required by the Contract Documents.

3.10.105 WEBB COUNTY's right to require Extraordinary Measures solely is for the purpose of ensuring Project Milestones and Substantial Completion of the Work is achieved within the Contract Time. Contractor shall not be entitled to an adjustment in the Contract Sum in connection with Extraordinary Measures required by WEBB COUNTY under or pursuant to this **Section 3.10.10.5**, except as may be provided under the provisions of **Section 4.3.11** herein.

3.10.106 WEBB COUNTY may exercise the rights furnished pursuant to this **Section 3.10.10.5** as frequently as WEBB COUNTY deems necessary to ensure Contractor's performance of the Work is in compliance with any milestone date or completion date(s) set forth in the Contract Documents.

3.10.107 If reasonably required by WEBB COUNTY, Contractor also shall prepare and furnish Project cash flow projections, manning data for critical activities and schedules for the purchase and delivery of all critical equipment and material, together with periodic updating thereof.

3.10.108 Contractor shall recommend to WEBB COUNTY and Design Consultant a schedule for procurement of long-lead time items, which shall constitute part of the Work as required to meet the Project Schedule.

### **3.10.11 PROJECT SCHEDULE TIME IMPACT ANALYSIS**

3.10.10.1 Contractor shall notify WEBB COUNTY when an impact may justify an extension of Contract time or adjustment of milestone dates. Said notice shall be made by Contractor in writing as soon as possible, but no later than the end of the next estimate period after the commencement of an impact or the notice for a change is given to Contractor. Not



providing notice to WEBB COUNTY within twenty (20) calendar days after receipt shall indicate Contractor's approval of the time charges as shown on that time statement. Future consideration of that statement shall not be permitted and Contractor forfeits its right to subsequently request a time extension or time suspension, unless the circumstances prove Contractor could not reasonably have knowledge of the impact by the end of the next estimate period.

3.10.11.1 When changes are initiated or impacts are experienced, Contractor shall submit to WEBB COUNTY a written Time Impact Analysis describing the influence of each change or impact. A "Time Impact Analysis" is an evaluation of the effects of changes in the construction sequence, contract, Plans or site conditions on Contractor's plan for constructing the Project, as represented by the schedule. The purpose of the Time Impact Analysis is to determine if the overall Project has been delayed and, if necessary, to provide Contractor and WEBB COUNTY a basis for making adjustments to the Contract.

3.10.11.2 A Time Impact Analysis shall consist of one or all of the steps listed below:

- (1) Establish the status of the Project before the impact using the most recent Project Schedule Update prior to the impact occurrence.
- (2) Predict the effect of the impact on the most recent Project Schedule Update prior to the impact occurrence. This requires estimating the duration of the impact and inserting the impact into the schedule update. Any other changes made to the schedule including modifications to the calendars or constraints shall be noted.
- (3) Track the effects of the impact on the schedule during its occurrence. Note any changes in sequencing and mitigation efforts.
- (4) Compare the status of the work prior to the impact (**#1 above**) to the prediction of the effect of the impact (**#2 above**), and to the status of the work during and after the effects of the impact are over (**#3 above**). Note: if an impact causes a lack of access to a portion of the Project, the effects of the impact may extend to include a reasonable period for remobilization.

3.10.11.3 The Time Impact Analysis shall be electronically submitted to WEBB COUNTY. If the Project Schedule is revised after the submittal of a Time Impact Analysis but prior to its approval, Contractor promptly shall indicate in writing to WEBB COUNTY the need for any modification to its Time Impact Analysis. One (1) copy of each Time Impact Analysis shall be submitted within fourteen (14) calendar days after the completion of an impact. WEBB COUNTY may require **Step 1** and **Step 2** in **Section 3.10.11.2** herein of the Time Impact Analysis be submitted at the commencement of the impact, if needed to make a decision regarding the suspension of Contract time. Approval or rejection of each Time Impact Analysis by WEBB COUNTY shall be made within fourteen (14) calendar days after receipt, unless subsequent meetings and negotiations are necessary.

### 3.11 DOCUMENTS AND SAMPLES AT THE SITE

3.11.1 Contractor shall maintain, on Site and for WEBB COUNTY's use, one record copy of the Drawings, Specifications, Addenda, Change Orders and other Amendments, in good order and currently marked, to record field changes and selections made during construction, along with one record copy of approved Shop Drawings, Product Data, Samples and similar required submittals. These record copies also shall be available to Design Consultant and shall be delivered to Design Consultant for submittal to WEBB COUNTY upon completion of the Work.

3.11.2 Contractor shall at all times maintain job records including, but not limited to, invoices, payment records, payroll records, daily reports, logs, diaries and job meeting minutes applicable to the Project. Contractor shall make such reports and records available for inspection by WEBB COUNTY, Design Consultant and/or their respective agents, during normal business hours if requested by WEBB COUNTY.

### **3.12 SHOP DRAWINGS, PRODUCT DATA AND SAMPLES**

3.12.1 Shop Drawings are drawings, diagrams, illustrations, schedules, performance charts, brochures and other data prepared and furnished by Contractor or its agents, manufacturers, suppliers or distributors and which illustrate and detail some portion of the Work.

3.12.2 Product Data are illustrations, standard schedules, performance charts, instructions, brochures, diagrams and other information furnished by Contractor to illustrate materials or equipment for some portion of the Work.

3.12.3 Samples are physical samples of materials, equipment, or workmanship representative of some portion of the Work, furnished by the Contractor to WEBB COUNTY, to assist WEBB COUNTY and Design Consultant in the establishment of workmanship and quality standards by which the Work shall be judged.

3.12.4 Shop Drawings, Product Data, Samples, and similar submittals are not Contract Documents. The purpose of their submittals is to demonstrate, for those portions of the Work for which submittals are required by the Contract Documents, the way by which Contractor proposes to conform to the information given and the design concept expressed in the Contract Documents. Review by Design Consultant is subject to the limitations of **Section 4.2.8** herein. Informational submittals, upon which Design Consultant is not expected to take responsive action, may be so identified in the Contract Documents. Submittals which are not required by the Contract Documents may be returned by the Design Consultant without action.

3.12.5 Contractor shall review for compliance with the Contract Documents, approve and submit to Design Consultant Shop Drawings, Product Data, Samples, and similar submittals required by the Contract Documents with reasonable promptness and in such sequence as to cause no delay in the Work or in the activities of WEBB COUNTY or of separate contractors. Submittals which are not marked as reviewed for compliance with the Contract Documents and approved by Contractor may be returned by Design Consultant without action.

3.12.6 By approving and submitting Shop Drawings, Product Data, Samples and similar

submittals, Contractor represents it has determined and verified materials, field measurements and filed construction criteria related thereto, or shall do so, and has checked and coordinated the information contained within such submittals with the requirements of the Work and of the Contract Documents.

3.127 Contractor shall perform no portion of the Work for which the Contract Documents require submittal and review of Shop Drawings, Product Data, Samples or similar submittals until the respective submittal and review has been approved by Design Consultant. Design Consultant shall review and return such submittals within ten (10) calendar days or within a reasonable period so as to not delay the project.

3.128 The Work shall be in accordance with approved submittals, except Contractor shall not be relieved of responsibility for deviations from requirements of the Contract Documents by Design Consultant's approval of Shop Drawings, Product Data, Samples or similar submittals unless Contractor specifically has informed Design Consultant in writing of such deviation at the time of submittal and:

- (1) Design Consultant has given written approval in the specific deviation as a minor change in the Work; or
- (2) A Change Order or Field Work Directive has been issued authorizing the deviation. Contractor shall not be relieved of responsibility for errors or omissions in Shop Drawings, Product Data, Samples or similar submittals by Design Consultant's approval thereof.

3.129 Contractor shall direct specific attention, in writing or on resubmitted Shop Drawings, Product Data, Samples or similar submittals, to revisions other than those requested by Design Consultant on previous submittals. In the absence of such written notice, Design Consultant's approval of a resubmission shall not apply to such revisions.

3.12.10 Contractor shall not be required to provide professional services which constitute the practice of architecture or engineering unless such services specifically are required by the Contract Documents for a portion of the Work or unless Contractor needs to provide such services in order to carry out Contractor's responsibilities for construction means, methods, techniques, sequences and procedures. Contractor shall not be required to provide professional services in violation of applicable law. If professional design services or certifications by a design professional related to systems, materials or equipment specifically are required of Contractor by the Contract Documents, WEBB COUNTY and Design Consultant shall specify all performance and design criteria such services must satisfy. Contractor shall cause such services or certifications to be provided by a properly Texas-licensed design professional, whose signature and seal shall appear on all drawings, calculations, Specifications, certifications, Shop Drawings and other submittals prepared by such professional. Shop Drawings and other submittals related to the Work designed or certified by such professional, if prepared by others, shall bear such professional's written approval when submitted to Design Consultant. WEBB COUNTY and Design Consultant shall be entitled to rely upon the adequacy, accuracy and completeness of the services, certifications or approvals performed by such design professionals, provided WEBB COUNTY

and Design Consultant have specified to Contractor all performance and design criteria such identified services must satisfy. Pursuant to this **Section 3.12.10**, Design Consultant shall review, approve or take other appropriate action on submittals only for the limited purpose of checking of conformance with information given and the design concept expressed in the Contract Documents. Contractor shall not be responsible for the adequacy of the performance or design criteria required by the Contract Documents.

### **3.13 USE OF SITE**

3.131 Contractor shall confine construction equipment, the storage of materials and equipment and the operations of workers to areas permitted by law, ordinances, permits or the requirements of the Contract Documents and shall not unreasonably encumber the premises with construction equipment or other materials or equipment.

3.132 Contractor shall not load nor permit any part of any structure to be loaded in any manner that shall endanger the structure, nor shall Contractor subject any part of the Work or adjacent property to stresses or pressures that shall endanger it.

3.133 Contractor shall abide by all applicable rules and regulations of WEBB COUNTY with respect to conduct, including smoking, parking of vehicles, security regulations and entry into adjacent facilities owned by WEBB COUNTY.

3.134 Contractor shall provide access to residents and businesses affected by the construction of this Project to the greatest extent possible, including providing temporary base and asphalt as needed.

3.135 Contractor shall erect and maintain on Site a Project Bulletin Board, accessible to all Contractor and Subcontractor employees, upon which Contractor shall post and maintain, throughout the Project's duration, all employment and safety information required by law. Contractor further shall post complete Payment and Performance Bond information on the Project Bulletin Board, listing Contractor's bonding and insurance agencies/providers, to include agency contact names, address and telephone numbers.

3.136 As applicable, WEBB COUNTY shall have appropriate Temporary Bench Marks (hereafter referred to as "TBM") and a baseline (for both horizontal and vertical projects, as applicable) established. As of the date of the Notice To Proceed, it is Contractor's responsibility to protect, preserve and reestablish (if required) the TBM and/or baseline. Construction staking and tolerances shall be in accordance with the "Manual of Practice for Land Surveying in the State of Texas Category 5".

3.137 As applicable, Contractor shall layout its work from an established baseline and TBM indicated on the drawings and shall be responsible for all measurements in connection with the layout. Contractor shall furnish, at its own expense, all stakes, templates, platforms, equipment, tools, materials and labor required to layout any part of the work. Contractor shall provide cut sheets to WEBB COUNTY's inspector at minimum seven (7) calendar days prior to construction of street and drainage work. Contractor shall establish the necessary offsets, hubs and guards

marked showing control designation and offsets for Utility Work, if present. Contractor shall provide cut sheets for improvements where Sewer profiles are provided for various phases of the project and cut sheets for Water profiles, if applicable. Contractor shall provide staking and preparation of cut sheets after receiving notice to proceed from WEBB COUNTY. If present, Contractor shall provide City Utilities with cut sheets at minimum (7) calendar days prior to commence of utility work. Contractor shall be responsible for maintaining and preserving a baseline and TBM indicated on the drawings for duration of construction. If such marks are destroyed, Contractor shall replace them at its own expense. At the end of construction of the Project, Contractor shall provide WEBB COUNTY a grade certificate prepared by a Registered Professional Land Surveyor. This certificate shall state the infrastructure is constructed in accordance to the construction documents or as approved by WEBB COUNTY and the Engineer of Record, which is noted on the record plan set.

### **3.14 CUTTING AND PATCHING**

3.141 Contractor shall be responsible for all cutting, fitting or patching required to complete the Work or to make its parts fit together properly.

3.142 Contractor shall not damage or endanger a portion of the Work or a fully or partially completed construction by either WEBB COUNTY or separate contractors by cutting, patching or otherwise altering such construction, or by excavation. Contractor shall not cut or otherwise alter such construction by WEBB COUNTY or a separate contractor except with written consent of WEBB COUNTY and, if WEBB COUNTY so designates, of such separate contractor and said consent shall not be unreasonably withheld. Contractor unreasonably shall not withhold from WEBB COUNTY or WEBB COUNTY's separate contractor Contractor's consent to cutting or otherwise altering the Work.

3.143 Any part of the Work damaged by Contractor, either during installation or prior to Substantial Completion of the Work, shall be repaired by Contractor so as to be equal in quality, appearance, serviceability and other respects to an undamaged item or part of the Work. Where this repair cannot fully be accomplished, a damaged item or part shall be replaced by Contractor.

### **3.15 CLEANING UP**

3.151 During the progress of the Work, Contractor shall keep the Project Site and surrounding area including, but not limited to, creeks, drainage channels, easements and private property free from accumulations of waste materials, rubbish and other debris resulting from the Work. As applicable, Contractor shall clean, sweep, mop, brush and polish, as appropriate, the interior of the improvements and/or renovated areas including, but not limited to, any floors, carpeting, ducts, fixtures and ventilation units operated during construction, and shall clean exterior gutters, drainage, walkways, driveways and roofs of debris. If Contractor fails to clean up as provided in the Contract Documents, WEBB COUNTY may elect to do so and all costs incurred by WEBB COUNTY shall be paid by Contractor.

3.152 Prior to Substantial Completion of the Work, Contractor shall remove all waste materials, rubbish and debris from and about the premises, as well as all tools, appliances, construction equipment and machinery and surplus materials, and shall leave the Project Site clean and ready

for occupancy by WEBB COUNTY. As applicable, Contractor shall clean, sweep, mop, brush and polish, to WEBB COUNTY's satisfaction, the interior of the improvements and/or renovated areas including, but not limited to, any floors, carpeting, ducts, fixtures and ventilation units operated during construction, and shall clean exterior gutters, drainage, walkways, driveways and roofs of debris. Contractor shall restore to their original condition those portions of the Site not designated for alteration by the Contract Documents. If Contractor fails to clean up the premises as provided in the Contract Documents, WEBB COUNTY may elect to do so and all costs incurred by WEBB COUNTY shall be paid by Contractor.

### **3.16 ACCESS TO WORK.**

Contractor shall provide WEBB COUNTY and Design Consultant access to Work in preparation and in progress, wherever located.

### **3.17 PATENT FEES AND ROYALTIES.**

Contractor shall pay all license fees and royalties and assume all costs incident to the use of the performance of the Work or the incorporation in the Work of any invention, design, process, product or device which is the subject of patent rights or copyrights held by others. If a particular invention, design, process, product or device is specified in the Contract Documents for use in the performance of the Work and if to the actual knowledge of WEBB COUNTY its use is subject to patent rights or copyrights calling for the payment of any license fee or royalty to others, the existence of such rights shall be disclosed by WEBB COUNTY in the Contract Documents.

### **3.18 INDEMNITY PROVISIONS**

**3.18.1 CONTRACTOR COVENANTS AND AGREES TO FULLY INDEMNIFY, DEFEND AND HOLD HARMLESS, WEBB COUNTY AND ITS ELECTED OFFICIALS, EMPLOYEES, OFFICERS, DIRECTORS, VOLUNTEERS AND REPRESENTATIVES OF WEBB COUNTY, INDIVIDUALLY AND COLLECTIVELY, FROM AND AGAINST ANY AND ALL COSTS, CLAIMS (INCLUDING THIRD-PARTY CLAIMS), LIENS, DAMAGES, LOSSES, EXPENSES, FEES, FINES, PENALTIES, PROCEEDINGS, ACTIONS, DEMANDS, CAUSES OF ACTION, LIABILITY AND SUITS OF ANY KIND AND NATURE, INCLUDING BUT NOT LIMITED TO, PERSONAL OR BODILY INJURY, DEATH AND PROPERTY DAMAGE, MADE UPON WEBB COUNTY DIRECTLY OR ARISING OUT OF, RESULTING FROM OR RELATED TO CONTRACTOR'S ACTIVITIES UNDER THIS CONTRACT, INCLUDING ANY ACTS OR OMISSIONS OF CONTRACTOR, ANY AGENT, OFFICER, DIRECTOR, REPRESENTATIVE, EMPLOYEE, CONSULTANT OR SUBCONTRACTOR OF CONTRACTOR AND CONTRACTOR'S AND ITS SUBCONTRACTOR'S RESPECTIVE OFFICERS, AGENTS EMPLOYEES, DIRECTORS AND REPRESENTATIVES WHILE IN THE EXERCISE OF THE RIGHTS OR PERFORMANCE OF THE DUTIES UNDER THIS CONTRACT. THE INDEMNITY PROVIDED FOR IN THIS PARAGRAPH SHALL NOT APPLY TO ANY LIABILITY RESULTING FROM THE NEGLIGENCE OF WEBB COUNTY, ITS OFFICERS OR ITS EMPLOYEES IN INSTANCES WHERE SUCH NEGLIGENCE CAUSES PERSONAL INJURY, DEATH, OR PROPERTY DAMAGE. IN THE EVENT CONTRACTOR AND WEBB COUNTY ARE FOUND JOINTLY LIABLE BY A COURT OF COMPETENT JURISDICTION, LIABILITY SHALL BE**

**APPORTIONED COMPARATIVELY IN ACCORDANCE WITH THE LAWS FOR THE STATE OF TEXAS, WITHOUT, HOWEVER, WAIVING ANY GOVERNMENTAL IMMUNITY AVAILABLE TO WEBB COUNTY UNDER TEXAS LAW AND WITHOUT WAIVING ANY DEFENSES OF THE PARTIES UNDER TEXAS LAW.**

3.182 The provisions of this Indemnity solely are for the benefit of the Parties hereto and not intended to create or grant any rights, contractual or otherwise, to any other person or entity. Contractor shall advise WEBB COUNTY in writing within twenty-four (24) hours of any claim or demand against WEBB COUNTY or Contractor known to Contractor related to or arising out of Contractor's activities under this Contract and shall see to the investigation and defense of such claim or demand at Contractor's sole cost. WEBB COUNTY shall have the right, at its option and at its own expense, to participate in such defense without relieving Contractor of any of its obligations under this Section 3.18.

**3.183 INTELLECTUAL PROPERTY INDEMNIFICATION. CONTRACTOR SHALL PROTECT, INDEMNIFY, AND DEFEND AND/OR HANDLE AT ITS OWN COST AND EXPENSE ANY CLAIM OR ACTION AGAINST WEBB COUNTY , ITS ELECTED OFFICIALS, EMPLOYEES, OFFICERS, DIRECTORS, VOLUNTEERS AND REPRESENTATIVES OF WEBB COUNTY , INDIVIDUALLY OR COLLECTIVELY, FOR INFRINGEMENT OF ANY UNITED STATES PATENT, COPYRIGHT OR SIMILAR PROPERTY RIGHT INCLUDING, BUT NOT LIMITED TO, MISAPPROPRIATION OF TRADE SECRETS AND ANY INFRINGEMENT BY CONTRACTOR AND ITS EMPLOYEE OR ITS SUBCONTRACTORS AND THEIR AGENTS, SERVANTS AND EMPLOYEES, BASED ON ANY DELIVERABLE OR ANY OTHER MATERIALS FURNISHED HEREUNDER BY CONTRACTOR AND USED BY EITHER WEBB COUNTY OR CONTRACTOR WITHIN THE SCOPE OF THIS CONTRACT (UNLESS SAID INFRINGEMENT RESULTS DIRECTLY FROM CONTRACTOR'S COMPLIANCE WITH WEBB COUNTY'S WRITTEN STANDARDS OR SPECIFICATIONS). CONTRACTOR DOES NOT WARRANT AGAINST INFRINGEMENT BY REASON OF WEBB COUNTY'S OR DESIGN CONSULTANT'S DESIGN OF ARTICLES OR THEIR USE IN COMBINATION WITH OTHER MATERIALS OR IN THE OPERATION OF ANY PROCESS. CONTRACTOR SHALL HAVE THE SOLE RIGHT TO CONDUCT THE DEFENSE OF ANY SUCH CLAIM OR ACTION AND ALL NEGOTIATIONS FOR ITS SETTLEMENT OR COMPROMISE, UNLESS OTHERWISE MUTUALLY AGREED UPON, EXPRESSED IN WRITING AND SIGNED BY THE PARTIES HERETO. CONTRACTOR AGREES TO CONSULT WITH WEBB COUNTY'S ATTORNEY DURING SUCH DEFENSE OR NEGOTIATIONS AND MAKE GOOD FAITH EFFORTS TO AVOID ANY POSITION ADVERSE TO THE INTEREST OF WEBB COUNTY. WEBB COUNTY SHALL MAKE AVAILABLE TO CONTRACTOR ANY DELIVERABLES AND/OR WORKS MADE FOR HIRE BY CONTRACTOR NECESSARY TO THE DEFENSE OF CONTRACTOR AGAINST ANY CLAIM OF INFRINGEMENT FOR THE DURATION OF CONTRACTOR'S LEGAL DEFENSE.**

3.184 If such infringement claim or action has occurred or, in Contractor's judgment, is likely to occur, WEBB COUNTY shall allow Contractor, at Contractor's option and expense, (unless such infringement results directly from Contractor's compliance with WEBB COUNTY's written



standards or Specifications or by reason of WEBB COUNTY's or Design Consultants' design of articles or their use in combination with other materials or in the operation of any process for which WEBB COUNTY shall be liable) to elect to:

- (1) procure for WEBB COUNTY the right to continue using said deliverable and/or materials;
- (2) modify such deliverable and/or materials to become non- infringing (provided such modification does not adversely affect WEBB COUNTY's intended use of the deliverable and/or materials as contemplated hereunder);
- (3) replace said deliverable and/or materials with an equally suitable, compatible and functionally equivalent non- infringing deliverable and/or material at no additional charge to WEBB COUNTY; or
- (4) if none of the foregoing alternatives is reasonably available to Contractor, upon written request, WEBB COUNTY shall return the deliverable and/or materials in question to Contractor and Contractor shall refund all monies paid by WEBB COUNTY, with respect to such deliverable and/or materials, and accept return of same. If any such cure provided for in this **Section 3.18** shall fail to satisfy the third-party claimant, these actions shall not relieve Contractor from its defense and indemnity obligations set forth in this **Section 3.18**.

**3.185** The Indemnification obligations under this **Section 3.18** shall not be limited in any way by the limits of any insurance coverage or any limitation on the amount or type of damages, compensation or benefits payable by, for or to Contractor or any Subcontractor, supplier or any other individual or entity under any insurance policy, workers' compensation acts, disability benefit acts or other employee benefits acts.

**3.186 WORKER SAFETY.** The Indemnification hereunder shall include, without limiting the generality of the foregoing, liability which could arise to WEBB COUNTY, its agents, Consultants and/or representatives or Design Consultant pursuant to State statutes for the safety of Contractor's or its Subcontractors' workers and, in addition, all Federal statutes and rules existing there under for protection, occupational safety and health to workers. It is agreed the primary obligation of Contractor is to comply with these statutes in the performance by Contractor of the Work and the obligations of WEBB COUNTY, its agents, Consultants and representatives under said statutes are secondary to that of Contractor.

**3.187 DEFENSE COUNSEL.** If permitted by Contractor's insurance and its sureties WEBB COUNTY shall have the right to approve defense counsel, of which approval shall not be unreasonably withheld, to be retained by Contractor in fulfilling its obligation hereunder to defend and indemnify WEBB COUNTY, unless such right is expressly waived by WEBB COUNTY in writing. Contractor shall retain WEBB COUNTY - approved defense counsel within ten (10) calendar days of WEBB COUNTY's written notice WEBB COUNTY is invoking its right to Indemnification under this Contract. If Contractor fails to retain counsel within such time period, WEBB COUNTY shall have the right to retain defense counsel on its own behalf and Contractor shall be liable for all costs incurred by WEBB COUNTY. WEBB COUNTY also shall have the right, at its option, to be represented by advisory counsel of its own selection and at its own expense, without waiving the foregoing.

### **3.19 REPRESENTATIONS AND WARRANTIES.**

Contractor represents and warrants the following to WEBB COUNTY (in addition to the other representations and warranties contained in the Contract Documents), as an inducement to WEBB COUNTY to execute this Contract, which representations and warranties shall survive the execution and delivery of the Contract and the Final Completion of the Work, Contractor:

3.19.1 is financially solvent, able to pay its debts as they mature and possessed of sufficient working capital to complete the Work and perform its obligations under the Contract Documents;

3.19.2 is able to furnish the plant, tools, materials, supplies, equipment and labor required to complete the Work and perform its obligations hereunder and has sufficient experience and competence to do so;

3.19.3 is authorized to do business in the State of Texas and properly is licensed by all necessary governmental, public and quasi-public authorities having jurisdiction over it, the Work and the site of the Project;

3.19.4 is acting within its duly authorized powers to execute this Contract and execute the performance and obligations thereof; and

3.19.5 had directed its duly authorized representative(s) to visit the Site of the Work, familiarize itself with the local conditions under which the Work is to be performed and correlated its observations with the requirements of the Contract Documents.

### **3.20 BUSINESS STANDARDS.**

Contractor, in performing its obligations under this Contract, shall establish and maintain appropriate business standards, procedures and controls, including those necessary to avoid any real or apparent impropriety or adverse impact on the interest of WEBB COUNTY or affiliates. Contractor shall review with WEBB COUNTY, at a reasonable frequency during the performance of the Work hereunder, such business standards and procedures including, without limitation, those related to the activities of Contractor's employees, Subcontractors and agents in their relations with WEBB COUNTY's employees, Consultants, agents, representatives, vendors, Subcontractors, other third parties and those relating to the placement and administration of purchase orders and subcontracts.

## **ARTICLE IV. ADMINISTRATION OF THE CONTRACT**

### **41 DESIGN CONSULTANT.**

A Design Consultant is a person registered as an Architect pursuant to Tex. Occupations Code Ann., Chapter 1051, a Landscape Architect pursuant to Texas Occupations Code, Chapter 1052, and/or a person licensed as a professional Engineer pursuant to Texas Occupations Code, Chapter 1001, or a firm employed by WEBB COUNTY to provide professional architectural or engineering services and exercising overall responsibility for the design of a Project or a significant portion thereof, and performing certain contract administration responsibilities as set forth in its Contract and these General Conditions. If the employment of a Design Consultant is terminated, WEBB COUNTY shall employ a new Design Consultant whose status under the Contract Documents

shall be that of the former Design Consultant.

## **42 ROLES IN ADMINISTRATION OF THE CONTRACT**

42.1 WEBB COUNTY and Design Consultant shall provide administration of the Contract, as described in the Contract Documents, and Design Consultant shall be WEBB COUNTY's representative:

- (1) during construction;
- (2) until final payment is due; and
- (3) with WEBB COUNTY's concurrence, from time to time during the one- year period for correction of Work described in **Article XII** herein.

Design Consultant only shall have authority to act on behalf of WEBB COUNTY to the extent provided in the Contract Documents, unless otherwise modified in writing by WEBB COUNTY in accordance with other provisions of the Contract Documents.

42.2 WEBB COUNTY's instruction to Contractor may be issued through Design Consultant and WEBB COUNTY reserves the right to issue instructions directly to Contractor or through other designated WEBB COUNTY representatives. Contractor understands WEBB COUNTY may modify the authority of such Design Consultant as provided in the terms of its contractual relationship with Design Consultant, and WEBB COUNTY shall, in such event, be vested with powers formerly exercised by such Design Consultant, provided written notice of such modification immediately shall be served on Contractor. Nothing herein shall authorize independent agreements between Contractor and Design Consultant, nor shall Design Consultant be deemed to have a legal relationship with Contractor.

42.3 Neither Design Consultant nor WEBB COUNTY shall have control over, charge of nor be responsible for the construction means, methods or techniques, or for the safety precautions, quality control program and other programs in connection with the Work, since these solely are Contractor's rights and responsibilities under the Contract Documents. Sequencing and procedures shall be coordinated and agreed upon by WEBB COUNTY, Design Consultant and Contractor and shall remain the responsibility of Contractor for implementation.

42.4 Design Consultant shall not be responsible for Contractor's failure to perform the Work in accordance with the requirements of the Contract Documents. Design Consultant shall not have control over, charge of and shall not be responsible for acts or omissions of Contractor, Subcontractor, their respective agents, employees or any other persons or entities performing portions of the Work.

42.5 WEBB COUNTY and Contractor shall endeavor to communicate with each other directly, through Design Consultant and/or through the ODR about matters arising out of or relating to the Contract. Communications by and with Design Consultant's Consultants shall be through Design Consultant. Communications by WEBB COUNTY and Design Consultant with Contractor's employees Subcontractors and material suppliers shall be through Contractor. All communications

by and with WEBB COUNTY's separate contractors shall be through WEBB COUNTY.

426 Design Consultant shall review and approve or take other appropriate action upon Contractor's submittals such as Shop Drawings, Product Data and Samples, but only for the limited purpose of checking for conformance with information given and the design concept expressed in the Contract Documents. Design Consultant shall perform these reviews in a timely fashion so as to not delay the Work. Design Consultant promptly shall respond to submittals such as Shop Drawings, Product Data and Samples pursuant to the procedures set forth in the Project Specifications. Review of such submittals is not conducted for the purpose of determining the accuracy and completeness of equipment or systems, all of which remain the responsibility of Contractor as required by the Contract Documents. Design Consultant's review of Contractor's submittals shall not relieve the Contractor of the obligations under **Sections 3.3, 3.5 and 3.12** herein. Design Consultant's review shall not constitute approval of safety precautions or, unless otherwise specifically stated by Design Consultant, any construction means, methods, techniques, sequences or procedures. Design Consultant's approval of a specific item shall not indicate approval of an assembly of which the item is a component.

427 Upon written request of WEBB COUNTY or Contractor, Design Consultant shall issue its interpretation of the requirements of the Plans and Specifications. Design Consultant's response to such requests shall be made in writing within a time limit agreed upon or otherwise with reasonable promptness. If no agreement is made concerning the time within which interpretations required of Design Consultant shall be furnished in compliance with this **Section 4.2**, then no delay shall be recognized on account of any failure by Design Consultant to furnish such interpretations except for actual substantiated delays, for which Contractor is not responsible, occurring more than fifteen (15) calendar days after written request is made for the interpretations.

428 Interpretations and decisions of Design Consultant shall be consistent with the intent of and reasonably inferable from the Contract Documents and shall be in writing or in the form of drawings.

429 Design Consultant's decisions on matters relating to aesthetic effect shall be final if consistent with the intent expressed in the Contract Documents and not expressly overruled in writing by WEBB COUNTY.

#### **43 CLAIMS AND DISPUTES**

431 **DEFINITION.** A Claim is a demand or assertion by one of the Parties seeking, as a matter of right, an adjustment or interpretation of Contract terms, payment of money, extension of time or other relief, with respect to the terms of the Contract. The term "Claim" also includes other disputes and matters in question between WEBB COUNTY and Contractor arising out of or relating to the Contract. Claims must be initiated by written notice. Except as contemplated by **Section 8.2** herein, every Claim of Contractor, whether for additional compensation, additional time or other relief including, but not limited to, claims arising from concealed conditions, shall be signed and sworn to by an authorized corporate officer (if not a corporation, then an official of the company authorized to bind Contractor by his/her signature) of Contractor, verifying the truth and accuracy of the Claim. The responsibility to substantiate a Claim shall rest with the Party making the Claim.

**432 TIME LIMIT ON CLAIMS.** Except for those Claims resulting from unusually severe weather, as addressed in **Section 4.3.6** herein, Contractor Claims must be initiated within fifteen (15) calendar days after occurrence of the event giving rise to such Claim. Claims by Contractor must be submitted by written notice to both WEBB COUNTY and Design Consultant. Claims by WEBB COUNTY must be submitted by written notice to Contractor. Failure by Contractor to submit written notice of the claim within fifteen (15) calendar days shall constitute a waiver of such claim.

**433 CONTINUING CONTRACT PERFORMANCE.** Pending final resolution of a Claim, except as otherwise agreed in writing or as provided in **Sections 4.5.1, Section 9.7.1 and Article 14.3** herein, Contractor shall proceed diligently with performance of the Contract and WEBB COUNTY shall continue to make payments in accordance with the Contract Documents.

**434 CLAIMS FOR CONCEALED OR UNKNOWN CONDITIONS.** If conditions are encountered at the Site which either are subsurface or are otherwise concealed physical conditions which were not known to Contractor and which differ materially from those indicated in the Contract Documents or in the reports of investigations and tests of subsurface and latent physical conditions provided by WEBB COUNTY to Contractor prior to the preparation by Contractor of its Bid, as referred to above, or are unknown physical conditions of an unusual nature, which differ materially from those ordinarily found to exist and generally recognized as inherent in construction activities of the character provided for in the Contract Documents in the general vicinity of the Project site, then Contractor promptly shall notify WEBB COUNTY and Design Consultant of such conditions before conditions are disturbed, and in no event more than three (3) workdays after first observation of the conditions. Upon notification by Contractor, Design Consultant promptly shall investigate such conditions and report its findings to WEBB COUNTY. If WEBB COUNTY and Contractor cannot agree on an adjustment to the Contract Sum or Contract Time, the adjustment shall be subject to dispute resolution pursuant to **Section 4.5** herein.

**435 CLAIMS FOR ADDITIONAL COST.** If Contractor wishes to make a Claim for an increase in the Contract Sum, written notice as provided in this **Section 4.3** shall be given and accepted by WEBB COUNTY before proceeding to execute the Work, provided prior notice is not required for Claims relating to an emergency endangering life or property. Contractor shall file a Claim in accordance with this **Section 4.3** if Contractor believes additional cost is involved for reasons including, but not limited to:

- (1) a written interpretation from Design Consultant;
- (2) an order by WEBB COUNTY to stop the Work where Contractor was not at fault;
- (3) a written order for a minor change in the Work issued by Design Consultant;
- (4) failure of payment by WEBB COUNTY ;

- (5) termination of the Contract by WEBB COUNTY for convenience;
- (6) WEBB COUNTY's suspension; or
- (7) other reasonable grounds.

#### 436 CLAIMS FOR ADDITIONAL TIME

436.1 If Contractor wishes to make Claim for an increase in the Contract Time, written notice, as required in this **Section 4.3**, shall be given. Contractor's Claim shall include an estimate of probable impact of delay on progress of the Work in accordance with **Section 3.10.11** herein. In the case of a continuing delay, only one Claim is necessary.

436.2 Contractor shall be entitled to an extension of the Contract Time for delays or disruptions due to unusually severe weather in excess of weather normally experienced at the job site, as determined from climatological data set forth by National Weather Service and which affects the Project's critical path. Contractor shall bear the entire economic risk of all-weather delays and disruptions. Contractor shall not be entitled to any increase in the Contract Sum by reason of such delays or disruptions. With regard to Vertical projects with WEBB COUNTY, requests for an extension of time, pursuant to this **Section 4.3.6**, shall be submitted to WEBB COUNTY and Design Consultant not later than the fifteenth (15<sup>th</sup>) calendar day of the month following the month during which the delays or disruptions occurred and shall include documentation and all details reasonably available, demonstrating the nature and duration of the delays or disruptions and their effect on the critical path of the Schedule. With regard to Horizontal projects with WEBB COUNTY, upon Contractor reaching Substantial Completion, WEBB COUNTY and Contractor shall look back at the entire duration of the calendar day Project and review the totality of what Contractor claims were unusually severe weather disruptions. If the Project was delayed or disrupted due to unusually severe weather in excess of weather normally experienced over the entire duration of the Project, Contractor may make a Claim for an extension of the Contract Time for delays or disruptions due to unusually severe weather in excess of weather normally experienced at the job site, as determined from climatological data set forth by National Weather Service and which affects the Project's critical path. Any time extension granted to Contractor for either Vertical or Horizontal projects under **Section 4.3.6** shall be non-compensatory.

**4.3.7 INJURY OR DAMAGE TO PERSON OR PROPERTY.** If either Party to the Contract suffers injury or damage to person or property because of an act or omission of the other Party or an act or omission of others for whose acts such other Party legally is responsible (including, with respect to WEBB COUNTY, the acts or omissions of WEBB COUNTY's separate contractors), written notice of such injury or damage, whether or not insured, shall be given to the other Party within a reasonable time not exceeding three (3) calendar days after the discovery of the injury or damage. The written notice shall provide sufficient detail to enable the other Party to investigate the injury or damage.

**4.3.8 CHANGE IN UNIT PRICES.** As applicable, if unit prices are stated in the Contract Documents or subsequently are agreed upon by WEBB COUNTY and Contractor and if quantities originally contemplated are materially changed in a proposed Change Order or Field Work

Directive, such that the application of such unit prices to quantities of Work proposed shall cause substantial inequity to WEBB COUNTY or Contractor, the applicable unit prices shall be equitably adjusted.

**4.3.9 CLAIMS FOR CONSEQUENTIAL DAMAGES.** Except as otherwise provided in this Contract, in calculating the amount of any Claim or any measure of damages for breach of contract (such provision to survive any termination following such breach), the following standards shall apply both to Claims by Contractor and to Claims by WEBB COUNTY:

4.3.9.1 No consequential, indirect, incidental, punitive or exemplary damages shall be allowed, whether or not foreseeable, regardless of whether based on breach of contract, tort (including negligence), indemnity, strict liability or other bases of liability.

4.3.9.2 No recovery shall be based on a comparison of planned expenditures to total actual expenditures, on estimated losses of labor efficiency, on a comparison of planned man loading to actual man loading or on any other similar analysis used to show total cost or other damages.

4.3.9.3 Damages are limited to extra costs specifically shown to directly have been caused by a proven wrong for which the other Party is claimed to be responsible.

4.3.9.4 The maximum amount of any recovery for delay, to the extent damages for delay are not otherwise disallowed by the terms of the Contract Documents, shall be as is provided in **Article VIII** herein.

4.3.9.5 No damages shall be allowed for home office overhead or other home office charges or any Eichleay formula calculation, except or unless as expressly authorized by the Contract Documents.

4.3.9.6 No profit shall be allowed on any damage Claim, except or unless as expressly authorized by the Contract Documents.

**4.3.10 SUBCONTRACTOR PASS-THROUGH CLAIMS.** In the event any Subcontractor of Contractor asserts a Claim to Contractor that Contractor seeks to pass through to WEBB COUNTY under the Contract Documents, any entitlement to submit and assert the Claim as to WEBB COUNTY shall be subject to:

4.3.10.1 the requirements of **Section 4.3** herein of these General Conditions; and

4.3.10.2 the following additional three (3) requirements listed below, all three of said additional requirements shall be conditions precedent to the entitlement of Contractor to seek and assert such Claim against WEBB COUNTY:

- (a) Contractor shall:
- (b) have direct legal liability as a matter of contract, common law or statutory law to Subcontractor for the claim Subcontractor is asserting; or



- (c) have entered into a written liquidating agreement with Subcontractor, prior to the Claim's occurrence, under which Contractor has agreed to be legally responsible to the Subcontractor for pursuing the assertion of such Claim against WEBB COUNTY under said Contract and for paying to Subcontractor any amount that may be recovered, less Contractor's included markup (subject to the limits in the Contract Documents for any markup). The relationship, liability or responsibilities shall be identified in writing by Contractor to WEBB COUNTY at the time such Claim is submitted to WEBB COUNTY and a copy of any liquidating agreement shall be included by Contractor in the Claim submittal materials.
- (d) Contractor shall have reviewed the Claim of the Subcontractor prior to its submittal to WEBB COUNTY and independently shall have evaluated such Claim in good faith to determine the extent to which the Claim is believed in good faith to be valid. Contractor shall inform WEBB COUNTY it has made a review, evaluation and determination the Claim is being made in good faith and the claim is believed to be valid.
- (e) Subcontractor making the Claim to Contractor shall certify to both Contractor and WEBB COUNTY Subcontractor has compiled, reviewed and evaluated the merits of such Claim and the Claim is believed in good faith by Subcontractor to be valid. A copy of the certification by Subcontractor shall be included by Contractor in the Claim submittal materials.

43.103 Any failure of Contractor to comply with any of the foregoing requirements and conditions precedent with regard to any such Claim shall constitute a waiver of any entitlement to submit or pursue such Claim.

43.104 Receipt and review of a Claim by WEBB COUNTY under this Section 4.3 shall not be construed as a waiver of any defenses to the Claim available to WEBB COUNTY under the Contract Documents or at law.

**4.3.11 WEBB COUNTY'S RIGHT TO ORDER ACCELERATION AND TO DENY CLAIMED AND APPROPRIATE TIME EXTENSIONS, IN WHOLE OR IN PART.**

Contractor acknowledges and agrees Substantial Completion of the Work by or before the Scheduled Completion Date is of substantial importance to WEBB COUNTY. The following provisions, therefore, shall apply:

43.11.1 If Contractor falls behind the approved construction schedule for whatever reason, WEBB COUNTY shall have the right, in WEBB COUNTY's sole discretion, to order Contractor to develop a schedule recovery plan to alter its work sequences or to otherwise accelerate its progress in such a manner as to achieve Substantial Completion not later than the Contract Time completion date or such other date as WEBB COUNTY reasonably may direct but not earlier than the Contract Time for Substantial Completion. Upon receipt, Contractor shall take any and all action necessary to comply with WEBB COUNTY's order. In such event, any possible right, if any, of Contractor to additional compensation for any acceleration shall be subject to the terms of this Section 4.3.11. If WEBB COUNTY desires

to shorten the time for Substantial Completion, it may negotiate those terms with Contractor and if agreed to the details of costs and impacts, same will be evidenced by a Change Order signed by the Parties.

43.11.2 If WEBB COUNTY orders Contractor to accelerate the Work under **Section 4.3.11** herein, and Contractor would have been entitled to a time extension for a reason specifically allowed under the Contract Documents for an amount of time that would have justified approval by WEBB COUNTY if not for the need and right to complete the Project within the stipulated period, Contractor may initiate a Claim for schedule recovery or acceleration costs, pursuant to **Section 4.3** herein. Any resulting Claim for these costs properly initiated by Contractor under **Section 4.3** herein shall be limited to those reasonable and documented direct costs of labor, materials, equipment and supervision solely and directly attributable to the actual recovery or acceleration activity necessary for Contractor to bring the Work back within the then existing approved construction schedule. These direct costs of Contractor include, but are not limited to, the premium portion of overtime pay for additional crew, shift, or equipment costs, if requested in advance by Contractor and approved in writing by WEBB COUNTY. A percentage markup for the prorated cost of premium on the existing performance and payment bonds and required insurance, profit and field overhead, not to exceed the markups permitted by this Contract, shall be allowed on the claimed costs. **NO OTHER MARKUP FOR PROFIT, OVERHEAD (INCLUDING, BUT NOT LIMITED TO, HOME OFFICE OVERHEAD) OR ANY OTHER COSTS SHALL BE ALLOWED ON ANY ACCELERATION CLAIM.** WEBB COUNTY shall not be liable for any costs related to an acceleration claim other than those described in this **Section 4.3.11**.

**4.3.12 NO WAIVER OF GOVERNMENTAL IMMUNITY.** Nothing in this contract shall be construed to waive WEBB COUNTY's Governmental Immunity from a lawsuit, which Immunity is expressly retained to the extent it is not clearly and unambiguously waived by State law.

#### **4.4 RESOLUTION OF CLAIMS AND DISPUTES**

44.1 Claims by Contractor against WEBB COUNTY and Claims by WEBB COUNTY against Contractor, including those alleging an error or omission by Design Consultant but excluding those arising under **Section 10.3** and **Section 10.5** herein, shall be referred initially to Design Consultant for consideration and recommendation to WEBB COUNTY.

44.2 An initial recommendation by Design Consultant shall be required as a condition precedent to mediation or litigation of all Claims by the Parties arising prior to the date final payment is due, unless thirty (30) calendar days have passed after the Claim has been referred to Design Consultant with no recommendation having been rendered by Design Consultant.

44.3 Design Consultant shall review Claims and, within ten (10) work days of receipt of a Claim, take one or more of the following actions:

- (1) request additional supporting data from the Party making the Claim;
- (2) issue an initial recommendation;

- (3) suggest a compromise; or
- (4) advise the Parties that Design Consultant is unable to issue an initial Recommendation, due to a lack of sufficient information or conflict of interest.

444 Following receipt of Design Consultant's initial recommendation regarding a Claim, WEBB COUNTY and Contractor shall attempt to reach agreement as to any adjustment to the Contract Sum and/or Contract Time. If no agreement is reached, either Party may request mediation of the dispute, pursuant to **Section 4.5** herein.

445 If Design Consultant requests either or any Party to provide a response to a Claim or to furnish additional supporting data, such requested Party shall provide a response or the requested supporting data to Design Consultant, advise Design Consultant when the response or supporting data shall be furnished or advise Design Consultant that no response or supporting data shall be furnished.

446 With receipt of all information requested by Design Consultant, Design Consultant shall review the Claim and all received information within ten (10) calendar days of receipt of the information and shall take one of the following actions:

- (1) issue a recommendation;
- (2) suggest a compromise; or
- (3) advise the Parties Design Consultant is unable to issue a recommendation due to lack information or conflict of interest.

447 Upon Design Consultant's action or inaction, the Parties may agree to accept recommendations made by either Party or may request mediation of the dispute pursuant to **Section 4.5** herein.

448 **WAIVER OF LIEN.** It is understood that, by virtue of this Contract, no mechanic, contractor, material man, artisan or laborer, whether skilled or unskilled, ever shall, in any manner, have a claim or acquire any lien upon the building or any of the improvements of whatever nature or kind so erected or to be erected by virtue of this Contract, nor upon any of the land upon which said building or any of the improvements are so erected, built or situated.

## **4.5 ALTERNATIVE DISPUTE RESOLUTION**

451 **CONTINUATION OF WORK PENDING DISPUTE RESOLUTION.** Each Party is required to continue to perform its obligations under this Contract pending the final resolution of any dispute arising out of or relating to this Contract, unless it would be impossible or impracticable under the circumstances then present.

452 **REQUIREMENT FOR SENIOR LEVEL NEGOTIATIONS.** Before invoking mediation or any other alternative dispute process set forth herein, the Parties to this Contract

agree that they first shall try to resolve any dispute arising out of or related to this Contract through discussions directly between those senior management representatives within their respective organizations who have overall managerial responsibility for similar projects. Both WEBB COUNTY and Contractor agree that this step shall be a condition precedent to use of any other alternative dispute resolution process. If the Parties' senior management representatives cannot resolve the dispute within thirty (30) calendar days after a Party delivers a written notice of such dispute to the other, then the Parties shall proceed with the alternative dispute resolution process contained in **Section 4.5** herein, including mediation and/or litigation. All negotiations pursuant to this **Section 4.5** are confidential and shall be treated as compromise and settlement negotiations for purposes of applicable rules of evidence.

**4.53 MEDIATION.** In the event that WEBB COUNTY and/or Contractor contend that the other has committed a material breach of this Contract, or the Parties cannot reach a resolution of a claim or dispute pursuant to **Section 4.4** herein, as a condition preceding to filing a lawsuit, either Party shall request mediation of the dispute with the following requirements:

- 4.5.3.1 Request for mediation shall be in writing, and shall request that the mediation commence not less than thirty (30) or more than ninety (90) calendar days following the date of the request, except upon agreement of both Parties.
- 4.5.3.2 In the event WEBB COUNTY and Contractor are unable to agree to a date for the mediation or to the identity of the mediator(s) within thirty (30) calendar days following the date of the request for mediation, all conditions precedent in this **Section 4.5** shall be deemed to have occurred.
- 4.5.3.3 The Parties shall share the mediator's fee and any mediation filing fees equally. Venue for any mediation or lawsuit arising under this Contract shall be in Webb County, Texas. Any agreement reached in mediation shall be enforceable as a settlement agreement in any court having jurisdiction thereof. No provision of this Contract shall waive any immunity or defense. No provision of this Contract is consent to a suit.

#### **4.6 INTERNET-BASED PROJECT MANAGEMENT SYSTEMS.**

At its option, WEBB COUNTY may administer its design and construction management through an Internet-based Project Management system. In such cases, Contractor shall conduct communication through this medium and perform all Project-related functions utilizing this management system, to include all correspondences, submittals, Requests for Information, vouchers, payment requests and processing, Amendments, Change Orders and other administrative activities. When such a management system is employed, WEBB COUNTY shall administer the software, provide training to Project Team Members and shall make the software accessible via the Internet to all Project Team Members.

### **ARTICLE V. SUBCONTRACTORS**

#### **5.1 DEFINITION**

A Subcontractor is defined and used herein as a person or entity that has a direct contract with the

Contractor to perform a portion of the Work at the site. The term "Subcontractor" is referred to throughout the Contract Documents as if singular in number and means a Subcontractor, Sub-Consultant or an authorized representative of Subcontractor or Sub-Consultant. The term "Subcontractor" does not include a separate contractor or Subcontractor of a separate contractor.

## **5.2 AWARD OF SUBCONTRACTS AND OTHER CONTRACTS FOR PORTIONS OF THE WORK**

5.2.1 Contractor shall, prior to entering into an agreement with such Subcontractor, notify WEBB COUNTY in writing of the names of all proposed first-tier Subcontractors for the Work.

5.2.2 Contractor shall not employ any Subcontractor or other person or organization (including those who are to furnish the principal items of materials or equipment), whether initially or as a substitute, against whom WEBB COUNTY may have reasonable objection. A Subcontractor or other person or organization identified in writing to WEBB COUNTY, prior to the Notice of Award and not objected to in writing by WEBB COUNTY prior to the Notice of Award, shall be deemed acceptable to WEBB COUNTY. Acceptance of any Subcontractor, other person or organization by WEBB COUNTY shall not constitute a waiver of any right of WEBB COUNTY to reject defective Work. If WEBB COUNTY, after due investigation, has reasonable objection to any Subcontractor, other person or organization proposed by Contractor after the Notice of Award, Contractor shall be required to submit an acceptable substitute. Contractor shall not be required to employ any Subcontractor, other person or organization against whom Contractor has reasonable objection.

5.2.3 Contractor fully shall be responsible to WEBB COUNTY for all acts and omissions of its Subcontractors, persons and organizations directly or indirectly employed by them and persons and organizations for whose acts any of them may be liable to the same extent that Contractor is responsible for the acts and omissions of persons directly employed by Contractor. Nothing in the Contract Documents shall create any contractual relationship between WEBB COUNTY and any Subcontractor or other person or organization having a direct contract with Contractor, nor shall it create any obligation on the part of WEBB COUNTY to pay or to see to the payment of any moneys due any Subcontractor or other person or organization, except as may otherwise be required by law. WEBB COUNTY may furnish to any Subcontractor or other person or organization, to the extent practicable, evidence of amounts paid to Contractor on account of specific Work done.

5.2.4 The divisions and sections of the Specifications, as well as the identifications of any Drawings, shall not control Contractor in dividing the Work among Subcontractors or delineating the Work to be performed by any specific trade.

5.2.5 All Work performed for Contractor by a Subcontractor shall be performed pursuant to an appropriate agreement between Contractor and Subcontractor which specifically binds Subcontractor to the applicable terms and conditions of the Contract Documents for the benefit of WEBB COUNTY.

## **5.3 SUB-CONTRACTUAL RELATIONS**

5.3.1 By appropriate agreement, written where legally required for validity, Contractor shall require each Subcontractor, to the extent of the Work to be performed by Subcontractor, to be bound to Contractor by the same terms and conditions of the Contract Documents. Through that binding commitment, Subcontractor shall assume all the obligations and responsibilities, including the responsibility for safety of Subcontractor's Work and workers, which Contractor, by these Documents, assumes toward WEBB COUNTY and Design Consultant. Each Subcontractor agreement shall preserve and protect the rights of WEBB COUNTY and Design Consultant under the Contract Documents, with respect to the Work to be performed by Subcontractor, so that subcontracting thereof shall not prejudice such rights. Where appropriate, Contractor shall require each Subcontractor to enter into similar agreements with Sub-Subcontractors. Contractor shall make available to each proposed Subcontractor, prior to the execution of all Subcontractor agreement(s), copies of the Contract Documents to which Subcontractor(s) shall be bound. Subcontractors similarly shall make copies of applicable portions of such documents available to their respective proposed Sub-Subcontractors.

#### **5.4 CONTINGENT ASSIGNMENT OF SUBCONTRACTS**

Each Subcontractor agreement for a portion of the Work assigned by Contractor to WEBB COUNTY shall provide:

5.4.1 an assignment is effective only after termination of the Contract by WEBB COUNTY and only for those Subcontractor agreements which WEBB COUNTY accepts by notifying Subcontractor and Contractor in writing; and

5.4.2 an assignment is subject to the prior rights of the Surety, if any, obligated under bond relating to the Contract.

5.4.3 upon any such assignment, if the Work has been suspended for more than thirty (30) calendar days, Subcontractor's compensation equally shall be adjusted for increase in cost resulting from the suspension.

### **ARTICLE VI. CONSTRUCTION BY WEBB COUNTY OR BY SEPARATE CONTRACTS**

#### **6.1 WEBB COUNTY'S RIGHT TO PERFORM CONSTRUCTION AND TO AWARD SEPARATE CONTRACTS**

6.1.1 WEBB COUNTY reserves the right to perform construction or operations related to the Project with WEBB COUNTY's own forces and to award separate contracts in connection with other portions of the Project or other construction or operations on the Site under General Conditions of the Contract identical or substantially similar to these. If Contractor claims that a delay or additional cost is involved, due to such action by WEBB COUNTY, Contractor shall make a Claim as provided in **Section 4.3** herein.

6.1.2 When separate contracts are awarded for different portions of the Project or for other construction or operations on the Project Site, the term "Contractor" in the Contract Documents in each case shall mean the Contractor that executes each separate WEBB COUNTY Contractor contract.

6.1.3 WEBB COUNTY shall provide for coordination of the activities of WEBB COUNTY's own forces and of each separate contractor with the Work of Contractor and Contractor fully shall cooperate with said coordination. Contractor shall participate with other separate contractors and WEBB COUNTY in reviewing all construction schedules when directed by WEBB COUNTY to do so. Contractor shall make any revisions to its construction schedule deemed necessary after said joint review and mutual agreement. The revised construction schedules then shall constitute the schedules to be used by Contractor, separate contractors and WEBB COUNTY until subsequently revised.

6.1.4 Unless otherwise provided in the Contract Documents, when WEBB COUNTY and WEBB COUNTY's own forces perform construction or operation related to the Project, WEBB COUNTY shall be subject to the same obligations and to have the same rights that apply to Contractor under these General Conditions and the Contract Documents.

## 6.2 MUTUAL RESPONSIBILITY

6.2.1 Contractor shall afford WEBB COUNTY and WEBB COUNTY's separate contractor(s) reasonable opportunity for the introduction and storage of materials and equipment, the performance of their activities and the coordination of Contractor's construction and operations with theirs, as required by the Contract Documents.

6.2.2 If part of Contractor's Work depends upon the construction or operations by WEBB COUNTY or a separate contractor for the proper execution or results, Contractor shall, prior to proceeding with that portion of the Work, promptly report to WEBB COUNTY apparent discrepancies or defects in such other construction that would render it unsuitable for such proper execution and results. Failure of Contractor to so report shall constitute an acknowledgment that WEBB COUNTY's separate contractor's completed or partially completed construction is fit and proper to receive Contractor's Work, except as to defects not then reasonably discoverable.

6.2.3 WEBB COUNTY shall be reimbursed by Contractor for costs incurred by WEBB COUNTY which are payable to a separate contractor because of delays, improperly timed activities or defective construction of Contractor. WEBB COUNTY shall be responsible to Contractor for costs incurred by Contractor because of delays, improperly timed activities and damage to the Work or defective construction of WEBB COUNTY's separate contractor(s).

6.2.4 Contractor promptly shall remedy any damage wrongfully caused by Contractor or its Subcontractor(s) to any completed or partially completed construction or to property of WEBB COUNTY or WEBB COUNTY's separate contractor(s), as provided in **Section 10.2.5** herein.

6.2.5 WEBB COUNTY and each separate contractor shall have the same responsibilities for cutting and patching as are described for Contractor in **Section 3.14** herein.



### **6.3 WEBB COUNTY'S RIGHT TO CLEAN UP:**

If a dispute arises among or between Contractor, WEBB COUNTY's separate contractor(s) and WEBB COUNTY, as to the responsibility under their respective contracts for maintaining the premises and surrounding area free from waste materials and rubbish, WEBB COUNTY may clean up and those costs shall be allocated amongst those parties responsible. If Contractor does not agree to the allocation, the matter is to be settle as any other claim.

## **ARTICLE VII. CHANGES IN THE WORK**

### **7.1 GENERAL**

7.11 Changes in the Work may be accomplished, after the execution of the Contract and without invalidating the Contract, by Change Order, Field Work Directive/Force Account or order for a minor change in the Work that does not affect the Contract Time or the Contract Sum, subject to the limitations stated in this Article VII and elsewhere in the Contract Documents.

7.12 A Change Order shall be based upon agreement between WEBB COUNTY and Contractor; a Field Work Directive requires a directive by WEBB COUNTY and, if necessary, Design Consultant and may or may not be agreed to by Contractor; and an order for a minor change in the Work that does not affect the Contract Time or the Contract Sum may be issued by WEBB COUNTY.

7.13 Changes in the Work shall be performed under applicable provisions of the Contract Documents and Contractor promptly shall proceed with the changed Work, unless otherwise provided in a Change Order, Field Work Directive or order for a minor change in the Work or in this Article VII.

7.14 Changes resulting from Change Orders, Field Work Directives or orders for minor changes shall be recorded by Contractor on the As-Built record documents.

### **7.2 CHANGE ORDERS**

7.21 A Change Order is a written modification of the Contract signed by both WEBB COUNTY and Contractor (and approved by WEBB COUNTY COMMISSIONERS COURT, if required) that authorizes an addition, deletion or revision in the Work or an adjustment in the Contract Sum or the Contract Times and is issued on or after the Effective Date of the Contract.

7.22 Methods used in determining adjustments to the Contract Sum may include those listed in Section 7.3.4 herein.

7.23 Acceptance of a Change Order by Contractor shall constitute a full accord and satisfaction for any and all claims and costs of any kind, whether direct or indirect, including, but not limited to impact, delay or acceleration damages arising from the subject matter of the Change Order. Each Change Order shall be specific and final as to prices and any extensions of time, with no reservations or other provisions allowing for future additional money or time as a result of the

particular changes identified and fully compensated in the Change Order. The execution of a Change Order by Contractor shall constitute conclusive evidence of both Parties' agreement to the ordered changes in the Work, cost and additional time, if any. This Contract, as amended, forever releases any Claim against WEBB COUNTY for additional time or compensation for matters relating to or arising out of or resulting from the Work included within or affected by the executed Change Order. This release of any Claim applies to Claims related to the cumulative impact of all Change Orders and to any Claim related to the effect of a change on unchanged Work.

724 WEBB COUNTY or Design Consultant shall prepare Change Orders and Field Work Directives and shall have authority to order minor changes in the Work not involving an adjustment in the Contract Sum or an extension of the Contract Time. Such changes shall be effected by written order, which Contractor promptly shall carry out and record on the As-Built record documents.

725 Contractor and Subcontractors shall be entitled to include overhead and profit in any Change Order only as provided by Project Specifications.

### **7.3 FIELD WORK DIRECTIVES**

731 A Field Work Directive is a written directive signed by WEBB COUNTY and, if necessary, Design Consultant directing a change in the Work prior to agreement on an adjustment, if any, in the Contract Sum or Contract time, or both. WEBB COUNTY may, by Field Work Directive and without invalidating the Contract, order changes in the Work within the general scope of the Contract consisting of additions, deletions or other revisions, with any changes to the Contract Sum and/or the Contract Time to be adjusted according to the terms of this **Section 7.3**.

732 A Field Work Directive shall be used in the absence of total agreement on the terms of a Change Order. WEBB COUNTY shall issue a Field Work Directive to Contractor with a defined Not-To-Exceed dollar amount for the scope of Work defined pursuant to 7.3.4.

733 Upon receipt of a Field Work Directive, Contractor promptly shall proceed with the change in the Work involved and, in writing, advise WEBB COUNTY of the Contractor's agreement or disagreement with the method, if any, provided in the Field Work Directive for determining the proposed adjustment in the Contract Sum or Contract Time.

734 If the Field Work Directive provides for an adjustment to the Contract Sum, the adjustment shall be based on one of the following methods, as applicable:

- 7.3.4.1 mutual acceptance of a lump sum properly itemized and supported by sufficient substantiating data to permit evaluation;
- 7.3.4.2 prices, including unit prices, stated in the Contract Documents or subsequently agreed upon;
- 7.3.4.3 cost to be determined in a manner agreed upon by WEBB COUNTY and Contractor and a mutually acceptable fixed or percentage fee; or

- 7.3.4.4 as provided in **Section 7.3.6** herein.
- 7.3.4.5 If Contractor does not respond promptly or disagrees with the method for adjustment in the Contract Sum, the method and the adjustment shall initially be determined by Design Consultant on the basis of reasonable costs and savings attributable to the change including, in case of an increase in the Contract Sum, as applicable, a reasonable allowance for overhead and profit. In such case, and also under **Section 7.3.4.3** herein, Contractor shall keep and present, in such form as WEBB COUNTY may prescribe, an itemized and detailed accounting together with appropriate supporting data. Unless otherwise provided in the Contract Documents, costs for the purposes of this **Section 7.3.5** shall be limited to the following:
  - 7.3.4.6 costs of all labor, including social security, and unemployment insurance, fringe benefits required by Law, agreement or custom, and workers' compensation insurance;
  - 7.3.4.7 costs of all materials, supplies and equipment, including cost of transportation, storage installation, maintenance, dismantling and removal, whether incorporated or consumed;
  - 7.3.4.8 rental costs of all machinery and equipment, exclusive of hand tools, whether rented from Contractor or others, including costs of transportation, installation, minor repairs and replacements, dismantling and removal;
  - 7.3.4.9 expenses incurred in accordance with Contractor's standard personnel policy for travel approved in writing by WEBB COUNTY in advance;
  - 7.3.4.10 costs of premiums for all bonds and insurance, permit fees and allowable sales, use or similar taxes related to the Work;
  - 7.3.4.11 all additional costs of supervision and field office personnel directly attributable to the change; and
  - 7.3.4.12 all payments made by the Contractor to Subcontractors.

735 The amount of credit to be allowed by Contractor to WEBB COUNTY for a deletion or change which results in a net decrease in the Contract Sum shall be actual net cost of the deleted or change Work, plus Contractor's allocated percent for profit and overhead, as confirmed by Design Consultant, subject to any equitable adjustment recommended by Design Consultant and approved by WEBB COUNTY. When both additions and credits covering related Work or substitutions are involved in a change, the allowance for overhead and profit shall be figured on the basis of net increase or decrease, if any, with respect to that change.

736 If WEBB COUNTY and Contractor agree with the determination made by Design

Consultant concerning the adjustments in the Contract Sum and Contract Time, or otherwise reach agreement upon the adjustments, such agreement shall be effective immediately and shall be recorded by preparation and execution of an appropriate Change Order.

737 If WEBB COUNTY and Contractor cannot reach an agreement on either an adjustment on the Contract Sum and Contract Time, pursuant to an issued Field Work Directive, WEBB COUNTY and Contractor shall execute a Change Order for the adjustment on the Contract Sum or Contract Time, if any, the Parties do agree upon for the Work performed and Contractor reserves the right to file a Claim for any disagreements in Contract Sum or Contract Time not addressed in the Change Order, pursuant to **Section 4.4** herein. If WEBB COUNTY and Contractor cannot agree on both the adjustment in the Contract Sum and the Contract Time associated with an issued Field Work Directive, WEBB COUNTY unilaterally shall file a Change Order listing WEBB COUNTY's adjustments in the Contract Sum and/or Contract Time and Contractor reserves the right to file a Claim for payment and/or time, pursuant to **Section 4.4** herein.

#### **7.4 MINOR CHANGES TO THE WORK.**

WEBB COUNTY or Design Consultant both shall have authority to order minor changes in the Work not involving adjustment in the Contract Sum or extension of the Contract Time and not inconsistent with the intent of the Contract Documents. Such changes shall be effected by written order and shall be binding on WEBB COUNTY and Contractor. Contractor promptly shall carry out such written orders and record such changes in the As-Built drawings.

#### **7.5 TIME REQUIRED TO PROCESS CHANGE ORDERS**

751 All responses by Contractor to proposal requests from WEBB COUNTY or Design Consultant shall be accompanied by a complete itemized breakdown of costs. Responses to proposal requests shall be submitted sufficiently in advance of the required work to allow WEBB COUNTY and Design Consultant a minimum of thirty (30) calendar days after receipt by WEBB COUNTY to review the itemized breakdown and to prepare or distribute additional documents as may be necessary. Each of Contractor's responses to proposal requests shall include a statement that the cost and additional time described and requested in Contractor's response represents the complete, total and final cost and additional Contract Time associated with the extra work, change, addition to, omission, deviation, substitution or other grounds for seeking extra compensation or additional time under the Contract Documents, without reservation or further recourse.

752 All Change Orders require written approval by either WEBB COUNTY or WEBB COUNTY COMMISSIONERS COURT. The approval process requires a minimum of twenty (20) calendar days after submission to WEBB COUNTY in final form with all supporting data. Receipt of a submission by WEBB COUNTY does not constitute acceptance or approval of a proposal, nor does it constitute a warranty that the proposal shall be authorized by WEBB COUNTY or WEBB COUNTY COMMISSIONERS COURT Resolution or Administrative Action. **THE TIME REQUIRED FOR THE APPROVAL PROCESS SHALL NOT BE CONSIDERED A DELAY AND NO EXTENSIONS TO THE CONTRACT TIME OR INCREASE IN THE CONTRACT SUM SHALL BE CONSIDERED OR GRANTED AS A RESULT OF THIS PROCESS.** Pending the approval of a Change Order as described above, Contractor shall proceed with the work under a pending Change Order only if directed in writing to do so by WEBB

COUNTY.

## ARTICLE VIII. TIME

### 8.1 PROGRESS AND COMPLETION

8.1.1 **TIME LIMITS STATED IN THE CONTRACT DOCUMENTS ARE OF THE ESSENCE OF THE CONTRACT.** By executing the Contract, Contractor confirms that the Contract Time is a reasonable period for performing the Work.

8.1.2 Contractor shall proceed with the Work expeditiously using adequate forces and shall achieve Substantial Completion within the Contract Time.

8.1.3 For Projects not affecting WEBB COUNTY traffic, a determination made solely by WEBB COUNTY on a project-by-project basis, and a Working Day, as defined in **Section 1.1.1** herein, is measured from sunrise to sundown Monday through Friday, nothing in this **Article VIII** shall be construed as prohibiting Contractor from working on Saturdays if it so desires and giving WEBB COUNTY at least the prerequisite forty-eight (48) hours written notice of intent to perform Work on Saturday, Sunday and holidays so that WEBB COUNTY's representative may be scheduled to observe/inspect said Work and only if Contractor has performed work on the Project during the same week of the requested Saturday, Sunday or holiday.

8.1.4 On Projects affecting WEBB COUNTY traffic, a determination made solely by WEBB COUNTY on a project-by-project basis, Contractor shall work sunrise to sundown Monday through Saturday.

### 8.2 DELAYS AND EXTENSIONS OF TIME

8.2.1 Neither WEBB COUNTY nor Contractor, except as provided for in this **Section 8.2**, shall be liable to the other for any delay to Contractor's Work by reason of fire, act of God, riot, strike, pandemic or any other cause beyond either Party's direct control. Should any of these listed factors delay the Work's critical path, as evidenced by a Time Impact Analysis developed by Contractor and verified by Design Consultant, Program Manager and WEBB COUNTY, Contractor shall receive an extension of the Contract Times equal to the delay if a written claim is made within five (5) calendar days of the delaying event and granted by WEBB COUNTY. Under no circumstances shall WEBB COUNTY be liable to pay Contractor any compensation for such delays. Note that any request for an extension of time due to delays or disruption caused by unusually severe weather are addressed in **Section 4.3.6.2** herein.

8.2.2 Should Contractor be delayed solely by the act, negligence or default of WEBB COUNTY or Design Consultant, and should any of these factors delay the Project's critical path, as evidenced by a Time Impact Analysis developed by Contractor and verified by Design Consultant, Program Manager and WEBB COUNTY, Contractor shall receive an extension of the Contract Time equal to the verified delay or portion thereof if a written claim is made within five (5) calendar days of the act, negligence or default of WEBB COUNTY or Design Consultant and granted by WEBB COUNTY. In addition, Contractor, upon timely notice to WEBB COUNTY, with substantiation by WEBB COUNTY and Design Consultant and upon approval of WEBB COUNTY, shall be compensated for its Project facilities and field management expenses on a per diem basis (said per

diem includes the costs incurred by Contractor to administer its Work and does not include costs associated for any tier of Subcontractor or supplier to administer their Work. Compensation for Subcontractor's and supplier's compensable delay affecting the Project critical path shall be separate and apart from the per diem cost due and payable to the Contractor) for the particular Project delayed and for the period of the critical path delay attributable to a WEBB COUNTY caused event. In no event shall Contractor be entitled to home office or other off-site expenses or damages.

823 Claims relating to time shall be made in accordance with applicable provisions of **Section 4.3** herein.

824 This Contract does not permit the recovery of damages by Contractor for delay, disruption or acceleration, other than those described in **Section 8.2.2** herein, as provided under **Section 4.3.11(3)** herein and those justified by a Time Impact Analysis. Contractor agrees that it fully shall be compensated for all delays solely by an extension of non-compensatory time or as contemplated in **Section 8.2.2** herein.

## **ARTICLE IX. PAYMENTS AND COMPLETION**

### **91 CONTRACT SUM.**

The Contract Sum is stated in the Contract and, including authorized adjustments, is the total maximum not-to-exceed amount payable by WEBB COUNTY to Contractor for performance of the Work under the Contract Documents. Contractor accepts and agrees that all payments pursuant to this Contract are subject to the availability and appropriation of funds by the WEBB COUNTY COMMISSIONERS COURT. If funds are not available and/or appropriated, this Contract shall immediately be terminated with no liability to any Party to this Contract other than for the Work completed as of the date of termination.

### **92 SCHEDULE OF VALUES**

921 A Schedule of Values for all of the Work shall be submitted by Contractor and shall include quantities and prices of items which, when added together, equal a contract Price and subdivides the Work into component parts in sufficient detail to serve as the basis for progress payments during performance of the Work. Where applicable, overhead and profit shall be included as a separate line item.

922 Before the first Application for Payment, Contractor shall submit to WEBB COUNTY and Design Consultant a schedule of values allocated to various portions of the Work, prepared in such form and supported by such data to substantiate its accuracy as WEBB COUNTY and Design Consultant may require. This schedule, unless objected to by Design Consultant or WEBB COUNTY, shall be used as a basis for reviewing Contractor's Applications for Payment.

### **93 APPLICATIONS FOR PAYMENT**

93.1 Contractor shall submit Applications for Payment to WEBB COUNTY electronically, at minimum, every thirty (30) days throughout the duration of the Project or in the alternative upon

notice from Contractor that he is seeking only a complete payment upon Acceptance of the Project Contractor may submit a final Application for Payment. Contractor electronically shall attach to its Application for Payment all data substantiating Contractor's right to payment as WEBB COUNTY or Design Consultant may require, such as copies of requisitions from Subcontractors and material suppliers reflecting retainage, if provided for in the Contract Documents, and reflecting a deduction for Liquidated Damages, if applicable. Applications for Payment shall not include requests for payment for portions of the Work which Contractor does not intend to pay to a Subcontractor or material supplier, unless such Work has been performed by others whom Contractor intends to pay.

9.32 Unless otherwise provided in the Contract Documents, payments shall be made on account of materials and equipment delivered and suitably stored at the Site for subsequent incorporation in the Work and verified by WEBB COUNTY. If approved in advance in writing by WEBB COUNTY, payment similarly may be made for materials and equipment suitably stored off the Site at a location agreed upon in writing and verified by WEBB COUNTY. Payment for materials and equipment stored on or off the Site shall be conditioned upon compliance by Contractor with procedures reasonably satisfactory to WEBB COUNTY to establish WEBB COUNTY's title to such materials and equipment or otherwise protect WEBB COUNTY's interest. Contractor solely shall be responsible for payment of all costs of applicable insurance, storage and transportation to the site for materials and equipment stored off the site.

9.33 Contractor warrants that, upon submittal of an Application for Payment, all Work for which payment previously has been received from WEBB COUNTY shall, to the best of Contractor's knowledge, information and belief, be free and clear of liens, claims, security interests or encumbrances in favor of Contractor, Subcontractors, material suppliers or other persons or entities making a claim by reason of having provided labor, materials and equipment relating to the Work. **CONTRACTOR SHALL INDEMNIFY AND HOLD WEBB COUNTY HARMLESS FROM ANY LIENS, CLAIMS, SECURITY INTEREST OR ENCUMBRANCES FILED BY CONTRACTOR, SUBCONTRACTORS OR ANYONE CLAIMING BY, THROUGH OR UNDER CONTRACTOR OR SUBCONTRACTOR(S) FOR ITEMS COVERED BY PAYMENTS MADE BY WEBB COUNTY TO CONTRACTOR.**

9.34 By submission of an Application for Payment, Contractor certifies that there are no known liens or bond claims outstanding as of the date of said Application for Payment, that all due and payable bills with respect to the Work have been paid to date or are included in the amount requested in the current application and, except for such bills not paid but so included, there is no known basis for the filing of any liens or bond claims relating to the Work and that releases from all Subcontractors and Contractor's material men have been obtained in such form as to constitute an effective release of lien or claim under the laws of the State of Texas covering all Work theretofore performed and for which payment has been made by WEBB COUNTY to Contractor; provided if any of the foregoing is not true and cannot be certified, Contractor shall revise the certificate as appropriate and identify all exceptions to the requested certifications.

## **9.4 PAY APPLICATION APPROVAL**

9.4.1 Design Consultant shall, within five (5) business days after the electronic receipt of Contractor's Application for Payment either approve the Application for Payment or reject the



Application for Payment and state on the electronic notification to Contractor and WEBB COUNTY the Design Consultant's reasons for withholding approval, as provided in **Section 9.5.1** herein.

942 The certification of an Application for Payment shall constitute a representation by Design Consultant to WEBB COUNTY, based on Design Consultant's evaluation of the Work and the data comprising the Application for Payment, that the Work has progressed to the point indicated and that, to the best of Design Consultant's knowledge, information and belief, the quality of the Work is in accordance with the Contract Documents. The foregoing representations are subject to an evaluation of the Work for conformance with the Contract Documents upon Substantial Completion, to results of subsequent tests and inspections, to correction of minor deviations from the Contract Documents prior to completion and to any specific qualifications expressed by Design Consultant. The issuance of a Certificate for Payment further shall constitute a representation that Contractor is entitled to payment in the amount certified. However, the issuance of a Certificate for Payment shall not be a representation Design Consultant has:

- (1) made exhaustive or continuous on-site inspections to check the quality or quantity of the Work;
- (2) reviewed construction means, methods, techniques, sequences or procedures;
- (3) reviewed copies of requisitions received from Subcontractors and material suppliers and other data requested by WEBB COUNTY to substantiate Contractor's right to payment; or
- (4) made an examination to ascertain how or for what purpose Contractor has used money previously paid on account of the Contract Sum.

## **95 DECISIONS TO REJECT APPLICATION FOR PAYMENT**

95.1 The Application for Payment may be rejected to protect WEBB COUNTY for any of the following reasons:

- 9.5.1.1 Work not performed or defective as defined in 3.5.1;
- 9.5.1.2 damage to WEBB COUNTY;
- 9.5.1.3 reasonable evidence that the Work shall not be completed within the Contract Time, and that the unpaid balance would not be adequate to cover actual or Liquidated Damages for the anticipated delay;
- 9.5.1.4 persistent material failure by Contractor to substantially carry out the Work in accordance with the Contract Documents;
- 9.5.1.5 the applicable Liquidated Damages were not included in the Application for Payment;

9.5.1.6 billing for unapproved/unverified materials stored off Site; or

9.5.1.7 A current schedule update has not been submitted by Contractor.

952 WEBB COUNTY shall not be deemed in default by reason of rejecting Application for Payment as provided for in **Section 9.5.1** herein.

## **9.6 PROGRESS PAYMENTS**

961 After the final approval of the Application for Payment, WEBB COUNTY shall make payment in the manner and within the time provided in the Contract Documents.

962 During the latter part of each month, as the Work progresses on all WEBB COUNTY Contracts regardless of Contract Sum, WEBB COUNTY and Contractor shall determine the cost of the labor and materials incorporated into the Work during that month and actual invoiced cost of Contractor-acquired materials stored on the Project Site, and/or within off-site storage facilities either owned or leased by Contractor. Upon receipt of a complete and mathematically accurate Application for Payment from Contractor, WEBB COUNTY shall make payments, in accordance with **Article IX** herein, to Contractor within thirty (30) calendar days. Installments shall be paid to Contractor at the rate of ninety-five percent (95%) of each monthly invoice within thirty (30) calendar days of WEBB COUNTY receipt of a complete and mathematically accurate Application for Payment from the Contractor, and the retainage held until Final Completion shall be five percent (5%).

963 WEBB COUNTY's payment of installments shall not, in any way, be deemed to be a final acceptance by WEBB COUNTY of any part of the Work, shall not prejudice WEBB COUNTY in the final settlement of the Contract account or shall not relieve Contractor from completion of the Work herein provided.

964 Contractor shall, within ten (10) calendar days following receipt of payment from WEBB COUNTY, pay all bills for labor and materials performed and furnished by others in connection with the construction, furnishing and equipping of the improvements and the performance of the work, and shall, if requested, provide WEBB COUNTY with written evidence of such payment. Contractor's failure to make payments or provide written evidence of such payments within such time shall constitute a material breach of this contract, unless Contractor is able to demonstrate to WEBB COUNTY bona fide disputes associated with the unpaid Subcontractor(s) or supplier(s) and its/their work. Contractor shall include a provision in each of its subcontracts imposing the same written documentation of payment obligations on its Subcontractors as are applicable to Contractor hereunder, and if WEBB COUNTY so requests, shall provide copies of such Subcontractor payments to WEBB COUNTY. .

965 WEBB COUNTY and/or Design Consultant shall, if practicable and upon request, furnish to Subcontractor information regarding percentages of completion or amounts applied for by Contractor and action taken thereon by WEBB COUNTY and Design Consultant on account of portions of the Work done by such Subcontractor.

966 Neither WEBB COUNTY nor Design Consultant shall have an obligation to pay or to see to the payment of money to a Subcontractor, except as may otherwise be required by law, if any.

967 Payments to material suppliers shall be treated in a manner similar to that provided in **Section 9.6.2, Section 9.6.3 and Section 9.6.4** herein regarding Subcontractors.

968 A Certificate for Payment, a progress payment or a partial or entire use or occupancy of the Project by WEBB COUNTY shall not constitute acceptance of Work that was not performed or furnished in accordance with the Contract Documents.

969 Contractor shall, as a condition precedent to any obligation of WEBB COUNTY under this Contract, provide to WEBB COUNTY payment and performance bonds in the full penal amount of the Contract, in accordance with Texas Government Code Chapter 2253.

## **9.7 SUBSTANTIAL COMPLETION**

971 Substantial Completion is defined as the stage in the progress of the Work when the Work or a designated portion thereof, which WEBB COUNTY agrees to accept separately – sufficiently is complete, in accordance with the Contract Documents, so WEBB COUNTY may occupy or utilize the Work or a designated portion thereof for its intended use. In the event Substantial Completion is not achieved by the designated date, or the date extended by issued and accepted Change Order(s), WEBB COUNTY may withhold payment of sums necessary to pay the estimated Liquidated Damages due WEBB COUNTY. WEBB COUNTY shall be entitled, at any time, to deduct out of any sums due to Contractor any or all Liquidated Damages due WEBB COUNTY in accordance with the Contract between WEBB COUNTY and Contractor.

972 When Contractor considers that the Work, or a portion thereof which WEBB COUNTY agrees to accept separately, is Substantially Complete, Contractor shall prepare and submit to WEBB COUNTY and Design Consultant a preliminary comprehensive list of items to be completed or corrected prior to Final Completion and final payment. Failure to include an item on such list does not alter the responsibility of the Contractor to complete all Work in accordance with the Contract Documents.

973 Upon receipt of Contractor's list of items to be completed or corrected, WEBB COUNTY and Design Consultant shall make a Site inspection to determine whether the Work or designated portion thereof is Substantially Complete. If WEBB COUNTY's or Design Consultant's inspection discloses any item, whether or not it was included on Contractor's list of items to be completed or corrected, which is not sufficiently complete or correct in accordance with the Contract Documents so that WEBB COUNTY may occupy or utilize the Work or designated portion thereof for its intended use, Contractor shall, before issuance of the Certificate of Substantial Completion, complete or correct such item upon written notification by WEBB COUNTY or Design Consultant. In such case, Contractor then shall submit a request for another inspection by WEBB COUNTY and Design Consultant to determine Substantial Completion and Contractor shall be responsible for all reasonable and necessary costs incurred and associated with re-inspection.

974 When the Work – or the designated portion thereof which WEBB COUNTY agrees to accept separately – is Substantially Complete, Design Consultant or WEBB COUNTY shall prepare a Certificate of Substantial Completion (Vertical Projects) or a Letter of Conditional

Approval (Horizontal Projects) which shall:

- (1) establish the date of Substantial Completion (which shall be the date on which the Work met the requirements under the Contract Documents for Substantial Completion);
- (2) establish responsibilities of WEBB COUNTY and Contractor, as agreed to by WEBB COUNTY and Contractor, for security, maintenance, heat, utilities, damage to the Work and insurance; and
- (3) confirm the time limit by which Contractor shall complete all items on the list accompanying the Certificate.

Warranties required by the Contract Documents shall commence on the date of Substantial Completion of the Work, or the designated portion thereof, unless otherwise provided in the Certificate of Substantial Completion.

## **9.8 PARTIAL OCCUPANCY OR USE**

981 WEBB COUNTY may occupy or use any completed or partially completed portion of the Work at any stage of the Work when such partially completed portion is designated by separate agreement with Contractor, provided such occupancy or use is consented to by the insurer, as required under **Section 11.2.5** herein and authorized by public authorities having jurisdiction over the Work. Such partial occupancy or use may commence whether or not the portion is Substantially Complete, provided WEBB COUNTY and Contractor have accepted in writing the responsibilities assigned to each of them for security, maintenance, heat, utilities, damage to the Work and insurance and have agreed in writing concerning the period for correction of the Work and commencement of warranties required by the Contract Documents. When Contractor considers a portion of the Work to be Substantially Complete, Contractor shall prepare and submit a list of items to be completed or corrected prior to Final Completion and final payment and submit such list to WEBB COUNTY and Design Consultant, as provided under **Section 9.8.2** herein. Consent of Contractor to partial occupancy or use shall not be unreasonably withheld. The state of the progress of the Work shall be determined by written agreement between WEBB COUNTY and Contractor or, if no agreement is reached, by the decision of Design Consultant.

982 Immediately prior to such partial occupancy or use, WEBB COUNTY, Contractor and Design Consultant collectively shall inspect the area to be occupied or portion of the Work to be used in order to determine and record the condition of the Work.

983 Unless expressly agreed upon in writing, partial occupancy or use of a portion or portions of the Work shall not constitute acceptance of Work not complying with the requirements of the Contract Documents.

984 Upon such partial occupancy or use, and upon Substantial Completion, WEBB COUNTY shall assume responsibility for maintenance, security and insuring that portion of the Work that it has put into use.

985 Partial occupancy or use by WEBB COUNTY does not constitute substantial completion

and does not start any warranty period(s).

## **9.9 FINAL COMPLETION AND FINAL PAYMENT**

991 When all of the Work finally is completed and ready for final inspection, Contractor shall notify WEBB COUNTY and Design Consultant thereof in writing. Thereupon, WEBB COUNTY and Design Consultant shall make final inspection of the Work and, if the Work is complete in full accordance with this Contract and this Contract has been fully performed, the final Application for Payment may be submitted. If WEBB COUNTY and Design Consultant are unable to approve the final Application for Payment for reasons for which Contractor is responsible and WEBB COUNTY and Design Consultant are required to repeat a final inspection of the Work, Contractor shall be responsible for all reasonable and necessary costs incurred and associated with such repeat final inspection(s) and said costs may be deducted by WEBB COUNTY from the Contractor's retainage.

992 Contractor shall not be entitled to payment of retainage unless and until it submits to WEBB COUNTY its affidavit that the payrolls, invoices for materials and equipment, and other liabilities, to include Liquidated Damages, connected with the Work for which WEBB COUNTY or WEBB COUNTY's property might be responsible fully have been paid or otherwise satisfied or shall be paid from final payment; releases and waivers of liens from all Subcontractors of Contractor and of any and all other parties required by Design Consultant or WEBB COUNTY that either are unconditional or conditional on receipt of final payment; Certificates of insurance showing continuation of required insurance coverage; such other documents as WEBB COUNTY may request; and consent of Surety to final payment. A Retainage Checklist shall be provided by WEBB COUNTY to Contractor upon request. If Contractor has a dispute with a Subcontractor, Contractor will notify WEBB COUNTY of same and WEBB COUNTY may withhold the amount in dispute until the dispute is resolved but disburse the amounts that are not in dispute to Contractor. After Contractor provides satisfactory evidence to WEBB COUNTY that the dispute has been resolved, then WEBB COUNTY will distribute the withheld amount to Contractor.

993 If, after Substantial Completion of the Work, Final Completion of the Work materially is delayed through no fault of Contractor nor by Issuance of Change Orders affecting Final Completion of the Work, and Design Consultant so confirms, WEBB COUNTY shall, upon application by Contractor and certification by Design Consultant and without terminating the Contract, make payment of the balance due Contractor for that portion of the work fully completed and accepted. If the remaining balance for Work not fully completed or corrected is less than retainage stipulated in the Contract Documents, and if bonds have been furnished, the written consent of Surety to payment of the balance due for that portion of the Work fully completed and accepted shall be submitted by Contractor to Design Consultant, prior to certification of such payment. Such payment shall be made under the terms and conditions governing final payment, except that it shall not constitute a waiver of claims.

994 Request for final payment by Contractor shall constitute a waiver of all claims against WEBB COUNTY, except those previously made in writing and identified by that payee as unsettled at the time of final Application for Payment.

## **9.10 ADDITIONAL INSPECTIONS.**

In addition to any Liquidated Damages accrued by and payable to WEBB COUNTY by Contractor, WEBB COUNTY shall be entitled to deduct from the Contract Sum amounts due to Contractor by WEBB COUNTY to compensate Design Consultant for any additional inspections or services provided by Design Consultant, provided Design Consultant undertook these additional inspections or services due to the fault or negligence of Contractor if:

- (1) Design Consultant is required to make more than one inspection to determine if Substantial Completion has been achieved by Contractor;
- (2) Design Consultant is required to make more than one inspection to determine if Final Completion has been achieved by Contractor; or
- (3) the Work is not substantially complete within thirty (30) calendar days after the date established for the Work's Substantial Completion, as stated in the Contract Documents.

## **ARTICLE X. PROTECTION OF PERSONS AND PROPERTY**

### **10.1 SAFETY PRECAUTIONS AND PROGRAMS**

10.1.1 Contractor shall be responsible for initiating, maintaining and supervising all safety precautions and programs in connection with the performance of the Contract. Contractor shall develop a safety program applicable to each job site and to the Work to be done and enforce such program at all times. Further, Contractor shall comply with all applicable laws and regulations including, but not limited to, the standards and regulations promulgated by the Secretary of Labor under the Occupational Safety and Health Act of 1970 (OSHA) and any other legislation enacted for the safety and health of Contractor employees. WEBB COUNTY shall have the right, but not the obligation, to inspect and verify Contractor's compliance with Contractor's responsibility for protecting the safety and health of its employees and Subcontractor.

10.1.2 Contractor shall notify WEBB COUNTY immediately, by telephone with prompt confirmation in writing, of all injuries and fatalities including, but not limited to, copies of all reports and other documents filed or provided to Contractor's insurers and the State of Texas in connection with such injuries or fatalities.

10.1.3 Contractor has adopted or shall adopt its own policy to assure a drug and alcohol-free work place while performing the Work. Contractor's employees, agents, and Subcontractors shall not perform any service for WEBB COUNTY while under the influence of alcohol or any controlled substance. Contractor, its employees, agents and Subcontractors shall not use, possess, distribute or sell illegal, illicit and/or prescribed controlled drugs or drug paraphernalia or misuse legitimate prescription drugs while on Site or performing the Work. Contractor, its employees, agents and Subcontractors shall not use, possess, distribute or sell alcoholic beverages while performing the Work or while on Site or performing the Work. Contractor shall remove any of its employees or Subcontractor employees from performing the Work or from the Site any time there is reasonable suspicion of alcohol and/or drug use, possession or impairment involving such employee and at any time an incident occurs where drug or alcohol use could have been a contributing factor.

WEBB COUNTY has the right to require Contractor to remove employees or Subcontractor employees from performing the Work or from the Site any time reasonable, cause exists to suspect alcohol or drug use. In such cases, Contractor's or Subcontractor's employees only may be considered for return to work after Contractor certifies, as a result of a for-cause test conducted immediately following a removal, said employee was in compliance with this Contract. Contractor shall not employ any individual, or shall not accept any Subcontractor employees, to perform the Work who either refuses to take or tests positive in any alcohol or drug test.

10.14 Contractor shall comply with all applicable federal, state and local drug and alcohol related laws and regulations (e.g., Department of Transportation regulations, Department of Defense Drug-free Work-free Workforce Policy, Drug-Free Workplace Act of 1988). The presence of any firearms or other lethal weapons by any person is prohibited on the Project site, regardless of whether there exists a valid permit for carrying a weapon.

10.15 Both WEBB COUNTY and Contractor agree that these safety and health terms are of the highest importance and that a breach or violation of any of the terms of this **Section X** by Contractor or a Subcontractor shall be a material and substantial breach of this Contract. In the event that WEBB COUNTY shall reasonably determine that Contractor has breached or violated the terms of this Section that have a substantial, present probability of a significant accident (technical violations which do not pose an immediate danger are to be corrected but do not meet the definition of "substantial, present probability"), then WEBB COUNTY shall determine, immediately upon written notice to Contractor, whether the Work shall be suspended as a result thereof. If the Work is suspended, the Work shall not recommence until WEBB COUNTY is satisfied that the safety provisions hereof shall not be breached or violated thereafter. If WEBB COUNTY terminates the Contract as a result of such breach or violation, WEBB COUNTY and Contractor shall complete their obligations hereunder to one another in accordance with **Article XIII** herein. For minor, technical violations, WEBB COUNTY will provide Contractor notice to remedy promptly.

10.16 Nothing contained in this **Article X** shall be interpreted as creating or altering the legal duty of WEBB COUNTY to Contractor or to Contractor's agents, employees, Subcontractors or third parties, or altering the status of Contractor as an independent contractor.

10.17 Notwithstanding either of the above provisions, or whether WEBB COUNTY exercises its rights set forth herein, WEBB COUNTY neither warrants nor represents to Contractor, Contractor's employees or agents, any Subcontractors or any other third party that Contractor's safety policy meets the requirements of any applicable law, code, rule or regulation, nor does WEBB COUNTY warrant that the proper enforcement of Contractor's policy shall insure that no accidents or injuries shall occur. In addition, any action by WEBB COUNTY under these provisions in no way diminishes any of Contractor's obligations under applicable law or the contract documents.

## 10.2 SAFETY OF PERSONS AND PROPERTY

10.21 Contractor shall take reasonable precautions for the safety of and shall provide reasonable protection to prevent damage, injury or loss to:



- 10.2.1.1 employees performing the Work and other persons who may be affected thereby;
- 10.2.1.2 the Work and materials and equipment to be incorporated therein, whether in storage on or off the site, under the care, custody or control of Contractor or Contractor's Subcontractors or Sub-Subcontractors;
- 10.2.1.3 other property at the site or adjacent thereto, such as trees, shrubs, lawns, walks, pavements, roadways, structures and utilities not designated for removal, relocation or replacement in the course of Construction; and
- 10.2.1.4 the contents of a building or structure, when Contractor is working in, on or around an existing/operating WEBB COUNTY facility.

1022 Contractor shall give notices and comply with applicable laws, ordinances, rules, regulations and lawful orders of public authorities bearing on safety of persons or property or their protection from damage, injury or loss.

1023 Contractor shall erect and maintain, as required by existing conditions and performance of the Contract, reasonable safeguards for safety and protection, including posting danger signs and other warnings against hazards, promulgating safety regulations and notifying WEBB COUNTY and users of adjacent sites and utilities.

1024 When use or storage of explosives or other hazardous materials or equipment or unusual methods are necessary for the execution of the Work, Contractor shall exercise extraordinary care and shall carry on such activities under the direct supervision of properly qualified personnel. Prior to the use of any explosives, Contractor shall submit a written blasting plan, shall obtain WEBB COUNTY's approval and shall comply with WEBB COUNTY's requirements for such use.

1025 Contractor shall designate a responsible member of Contractor's organization at the site whose duty shall be the prevention of accidents. This person shall be Contractor's superintendent unless otherwise designated by Contractor in writing to WEBB COUNTY and Design Consultant.

1026 Contractor shall not load or permit any part of the construction or site to be loaded so as to endanger its safety.

1027 Notwithstanding the delivery of a survey or other documents by WEBB COUNTY, Contractor shall use reasonable efforts to perform all Work in such a manner so as to avoid damaging any utility lines, cables, pipes or pipelines on the property. Contractor acknowledges and accepts that the location of underground utilities (both public and private) reflected on any WEBB COUNTY provided Plans are not guaranteed and may not be completely accurate. Contractor shall locate and verify any and all utilities and associated service lines prior to beginning any Work. Contractor shall be responsible for and shall repair, at Contractor's own expense, any damage done to lines, cables, pipes and pipelines identified or not identified to Contractor.

### **10.3 EMERGENCIES**

1031 In an emergency affecting safety of persons or property, Contractor shall exercise its best efforts to act to prevent or minimize threatened damage, injury or loss. Additional compensation or extension of time claimed by Contractor on account of an emergency shall be determined, as provided in **Section 4.3** and **Article VII** herein.

1032 If Contractor causes damage resulting in an issue of safety and/or security to a property WEBB COUNTY, Contractor immediately shall repair any damage caused. If Contractor does not or shall not act immediately to repair the damage caused by Contractor to eliminate the resulting safety and/or security issue(s), WEBB COUNTY shall act to repair the damage caused and deduct all costs associated with the repair from any money due Contractor.

### **10.4 PUBLIC CONVENIENCE AND SAFETY**

1041 Contractor shall place materials stored at the Project site and shall conduct the Work at all times in a manner that causes no greater obstruction to the public than is considered necessary by WEBB COUNTY. Sidewalks or streets shall not be obstructed, except by special permission of WEBB COUNTY. Materials excavated and construction materials or plants used in the performance of the Work shall be placed in a manner that does not endanger the Work or prevent free access to all fire hydrants, water mains and appurtenances, water valves, gas valves, manholes for the telephone, telegraph signal or electric conduits, wastewater mains and appurtenances and fire alarm or police call boxes in the vicinity.

1042 WEBB COUNTY reserves the right to remedy any neglect on the part of Contractor, in regard to public convenience and safety, which may come to WEBB COUNTY's attention after twenty-four (24) hours notice in writing to Contractor. In case of an emergency, WEBB COUNTY shall have the right immediately to remedy any neglect without notice. In either case, the reasonable and necessary cost of any work done by or for WEBB COUNTY to remedy Contractor's neglect shall be deducted by WEBB COUNTY from Contractor's Contract Sum. Contractor shall notify WEBB COUNTY, Design Consultant when any street is to be closed or obstructed. The notice shall, in the case of major thoroughfares or street upon which transit lines operate, be given at least forty- eight (48) hours in advance. WEBB COUNTY reserves the right to postpone and/or prohibit any closure or obstruction of any streets or thoroughfares, to the extent necessary for the safety and benefit of the traveling public. Contractor shall, when directed by WEBB COUNTY or Design Consultant, keep any street or streets in condition for unobstructed use. When Contractor is required to construct temporary bridges or make other arrangements for crossing over ditches or around structures, Contractor's responsibility for accidents shall include the roadway approaches as well as the crossing structures.

1043 Contractor shall limit airborne dust and debris throughout the Project site and its duration. Contractor shall apply the necessary amounts of water or other appropriate substance required to maintain sufficient moisture content for dust control. For WEBB COUNTY horizontal projects, Contractor shall apply appropriate amounts of water or other appropriate substance to the base on streets under construction and on detours required to maintain sufficient moisture control in the surface layer for dust control.

## **10.5 BARRICADES, LIGHTS AND WATCHMEN.**

If the Work is carried on, in or adjacent to any street, alley or public place, Contractor shall, at Contractor's own cost and expense, furnish, erect and maintain sufficient barricades, fences, lights and danger signals, provide sufficient watchmen and take such other precautionary measures as are necessary for the protection of persons or property and of the Work. All barricades shall be painted in a color that shall be visible at night, and shall be illuminated by lights as required under WEBB COUNTY's or TxDOT's Barricades Specifications. The term "lights," as used in this Section 10.5, shall mean flares, flashers or other illuminated devices. A sufficient number of barricades with adequate markings and directional devices also shall be erected to keep vehicles from being driven on or into any Work under construction. Contractor shall be held responsible for all damage to the Work due to Contractor's failing to maintain barricades, signs, lights and/or watchmen necessary to protect the Work. Whenever evidence is found of such damage, WEBB COUNTY or Design Consultant may order the damaged portion immediately removed and replaced by Contractor at Contractor's sole cost and expense, unless caused by WEBB COUNTY's employees or agents. Contractor reserves its cause of action against anyone causing the damage. Contractor's responsibility for maintenance of barricades, signs, lights, and for providing watchmen, as required under this Section 10.5, shall not cease until the Project has been finally accepted by WEBB COUNTY.

## **10.6 PUBLIC UTILITIES AND OTHER PROPERTIES TO BE CHANGED.**

In case it is necessary for Contractor to change or move the property of WEBB COUNTY or of any telecommunications or public utility, such property shall not be touched, removed or interfered with until ordered to do so by WEBB COUNTY. WEBB COUNTY reserves the right to grant any public or private utility personnel the authority to enter upon the Project site for the purpose of making such changes or repairs to their property that may become necessary during the performance of the Work. WEBB COUNTY reserves the right of entry upon the Project site at any time and for any purpose, including repairing or relaying sewer and water lines and appurtenances, repairing structures and for making other repairs, changes, or extensions to any of WEBB COUNTY's property. WEBB COUNTY's actions shall conform to Contractor's current and approved schedule for the performance of the Work, provided that proper notification of schedule requirements has been given to WEBB COUNTY by Contractor. Any damage to Contractor's Work must be repaired forthwith by those causing same. If caused by WEBB COUNTY (and/or those acting at its directions) and it does not remedy same timely to allow Contractor to fulfill its schedule, then Contractor will be granted additional time under Contractor deadlines to completions. If Contractor must remedy the damage in an attempt to maintain its schedule, then Contractor will be reimbursed the reasonable and necessary costs therefor.

## **10.7 TEMPORARY STORM SEWER AND DRAIN CONNECTIONS.**

When existing storm sewers or drains have to be taken up or removed, Contractor shall, at its expense, provide and maintain temporary outlets and connections for all public and private storm sewers and drains. Contractor also shall provide for all storm sewage and drainage which shall be received from these storm drains and sewers. For this purpose, Contractor shall provide and maintain, at Contractor's own expense, adequate pumping facilities and temporary outlets or diversions. Contractor shall, at Contractor's own expense, construct such troughs, pipes or other structures that may be necessary and shall be prepared at all times to dispose of storm drainage

and sewage received from these temporary connections until such time as the permanent connections are built and are in service. The existing storm sewers and connections shall be kept in service and maintained under the Contract, except where specified or ordered to be abandoned by Design Consultant. All storm water and sewage shall be disposed of in a satisfactory and lawful manner so that no nuisance is created and that the Work under construction shall be adequately protected.

## **10.8 ARRANGEMENT AND CHARGE FOR WATER, ELECTRICAL OR WIRELESS ACCESS FOR THE PROJECT**

1081 When Contractor desires to use water in connection with the Work, Contractor shall make complete and satisfactory arrangements with the appropriate water utility and shall be responsible for the cost of the water Contractor uses.

1082 Contractor shall make complete and satisfactory arrangements for electricity and metered electrical connections with the appropriate retail electric provider, in the event that separately metered electrical connections are required for the Project. Contractor shall pay for all electricity Contractor used in the performance of the Work through separate metered electrical connections obtained by Contractor through a retail electric provider.

1083 If Contractor elects or is required by WEBB COUNTY to place and operate out of a construction trailer or office on the Project site, for which all related costs shall be borne by Contractor, Contractor shall provide for an electronic device to exchange data wirelessly via a local area computer network, to include high-speed internet connections (commonly known as "Wi Fi access"), for WEBB COUNTY personnel's use while on the Project site for the duration of the Project.

## **10.9 USE OF FIRE HYDRANTS.**

Contractor, Subcontractors and any other person working on the Project shall not open, turn off, interfere with, attach any pipe or hose to or connect anything with any fire hydrant, stop valve or stop cock, or tap any water main unless duly authorized in writing to do so by the utility's owner.

## **10.10 ENVIRONMENTAL COMPLIANCE**

10.101 Contractor and its Subcontractors shall use their best efforts to comply with any and all applicable federal, state or local laws, rules, regulations, ordinances and rules of common law now in effect (including any amendments now in effect), relating to the environment, Hazardous Substances or exposure to Hazardous Substances including, but not limited to, the Comprehensive Environmental Response, Compensation and Liability Act of 1980, 42 U.S.C.A. §§ 9601, et seq.; the Hazardous Materials Transportation Act, 49 U.S.C.A. §§ 1801, et seq.; the Resource Conservation and Recovery Act of 1976, 42 U.S.C.A. §§ 6901, et seq.; the Federal Water Pollution Control Act, 33 U.S.C.A §§ 1201, et seq.; the Toxic Substances Control Act, 15 U.S.C.A. §§ 2601, et seq.; the Clean Air Act, 42 U.S.C.A. §§ 7401, et seq.; the Safe Drinking Water Act, 42 U.S.C.A. §§ 3808, et seq., and any current judicial or administrative interpretation of these laws, rules, regulations, ordinances or rules of common law including, but not limited to, any judicial or

administrative order, consent decree or judgment affecting the Project.

10.102 In the event Contractor encounters on the Project Site materials reasonably believed to be a Hazardous Substance that have not been rendered harmless, and the removal of such materials is not a part of the scope of Work required under the Contract Documents, Contractor immediately shall stop Work in the affected area and report in writing the facts of such encounter to WEBB COUNTY and Design Consultant. Work in the affected area shall not thereafter be resumed except by written order of WEBB COUNTY and written consent of Contractor, unless and until the material is determined not to be a Hazardous Substance or the Hazardous Substance is remediated. Unless removal of such materials is a part of the scope of Work required under the Contract Documents, WEBB COUNTY shall remediate the Hazardous Substance with a separate contractor or through a Change Order with Contractor. If the Hazardous Substance exists in the affected area due to the fault or negligence of Contractor or any of its Subcontractors, Contractor shall be responsible for remediating the condition at the sole expense of Contractor. If applicable, such remediation shall be in accordance with Contractor's Spill Remediation Plan. An extension of the Contract Time for any delay in the progress schedule caused as a result of the discovery and remediation of a Hazardous Substance may be granted by WEBB COUNTY only if the Project critical path is affected and Contractor is not the source of the Hazardous Substance. Any request for an extension of the Contract Time related to the discovery and remediation of a Hazardous Substance is subject to the provisions of **Section 4.3** and **Article VIII** herein.

10.103 Contractor shall be responsible for identification, abatement, cleanup, control, removal, remediation and disposal of any Hazardous Substance brought into or onto the site by Contractor or any Subcontractor or Contractor's Supplier. Contractor shall obtain any and all permits necessary for the legal and proper handling, transportation and disposal of the Hazardous Substance and shall, prior to undertaking any abatement, cleanup, control, removal, remediation and/or disposal, notify WEBB COUNTY and Design Consultant so that they may observe the activities; provided, however, that it shall be Contractor's sole responsibility to comply with all applicable laws, rules, regulations or ordinances governing said activities.

## **ARTICLE XI. INSURANCE AND BONDS**

### **11.1 CONTRACTOR'S LIABILITY INSURANCE**

11.1.1 Prior to the commencement of any work under this Contract, Contractor shall furnish copies of all required endorsements and completed Certificate(s) of Insurance to WEBB COUNTY, which shall be clearly labeled "**The Casa Blanca Golf Course Golf Path Project**" in the Description of Operations block of the Certificate. The Certificate(s) shall be completed by an agent and signed by a person authorized by that insurer to bind coverage on its behalf. WEBB COUNTY shall not accept a Memorandum of Insurance or Binder as proof of insurance. The Certificate(s) shall be signed by the Authorized Representative of the insurance carrier and shall include the agent's original signature and telephone number. The Certificate(s) shall be mailed, with copies of all applicable endorsements, directly from the insurer's authorized representative to WEBB COUNTY. WEBB COUNTY shall have no duty to pay or perform its obligations under this Contract until such Certificate(s) and endorsements have been received and approved by WEBB COUNTY. No officer or employee of WEBB COUNTY, other than the WEBB COUNTY Commissioners Court, shall have authority to waive this requirement.

11.12 WEBB COUNTY reserves the right to review the insurance requirements of this **Article XI** during the effective period of this Contract and to modify insurance coverages and limits when deemed necessary and prudent by the WEBB COUNTY's Risk Manager based upon changes in statutory law, court decisions, or circumstances surrounding this Contract. If WEBB COUNTY increases the insurance after providing Contractor the Order to Proceed, then WEBB COUNTY must provide Contractor a reasonable time to obtain same and reimburse Contractor the increase in cost of premiums related thereto. In no instance will WEBB COUNTY allow modification whereby WEBB COUNTY may incur increased risk.

11.13 Contractor's financial integrity is of interest to WEBB COUNTY; therefore, subject to Contractor's right to maintain reasonable deductibles in such amounts as are approved by WEBB COUNTY, Contractor shall obtain and maintain in full force and effect, for the duration of this Contract and at Contractor's sole expense, insurance coverage written on an occurrence basis, unless otherwise indicated, by companies authorized to do business in the State of Texas and with an A.M Best's rating of no less than A- (VII), in the following types and for an amount not less than the amount listed below:

<u>TYPE</u>	<u>AMOUNTS</u>
1. Workers' Compensation 2. Employers' Liability	Statutory \$500,000.00
3. Commercial General Liability Insurance to include coverage for the following:  a. Premises/Operations b. Products/Completed Operations (to be maintained and in effect for no less than two years subsequent to the completion of the project) c. Personal/Advertising Injury  *d. Environmental Impairment/Impact – sufficiently broad to cover disposal liability. *e. Explosion, Collapse, Underground	For <u>Bodily Injury</u> and <u>Property Damage</u> of:  \$1,000,000.00 per occurrence; \$2,000,000.00 General Aggregate, or its equivalent in Umbrella or Excess Liability Coverage \$2,000,000.00 Products/Completed Operations Aggregate
4. Business Automobile Liability:  a. Owned/leased vehicles b. Non-owned vehicles c. Hired Vehicles	Combined Single Limit for Bodily Injury and Property Damage of \$1,000,000.00 per occurrence

<p>5. *Umbrella Liability – To have as its underlying:</p> <ul style="list-style-type: none"> <li>a. General liability, including products/completed operations</li> <li>b. Automobile liability</li> <li>c. Employers' liability</li> </ul>	<p>Combined Single Limit for bodily injury and property damage of not less than \$5,000,000 per occurrence, \$5,000,000 general aggregate and \$5,000,000 products/completed operations aggregate</p>
<p>6. *Professional Liability (Claims-made basis) To be maintained and in effect for no less than two years subsequent to the completion of the professional service.</p>	<p>\$1,000,000.00 per claim, to pay on behalf of the insured all sums which the insured shall become legally obligated to pay as damages by reason of any wrongful act, malpractice, error, or omission in professional services.</p>
<p>7. *Builder's Risk</p>	<p>All Risk Policy written on an occurrence basis for 100% replacement cost during construction phase of any new or existing structure.</p>
<p><b>*Not Required</b></p>	

11.14 Contractor agrees to require, by written contract, all Subcontractors providing goods or services pursuant to performance on the Project obtain the same categories of insurance coverage required of Contractor herein and provide a Certificate of Insurance and endorsement that names Contractor and WEBB COUNTY as additional insureds. Policy limits of the coverages carried by Subcontractors shall be determined as a business decision of Contractor. Contractor shall provide WEBB COUNTY with said Certificate and endorsement prior to the commencement of any work by the Subcontractor. This Subcontractor insurance provision may be modified by the WEBB COUNTY's Risk Manager, without subsequent WEBB COUNTY COMMISSIONERS COURT approval, when deemed necessary and prudent, based upon changes in statutory law, court decisions, or circumstances surrounding this Contract. Such insurance coverage modification may be enacted by letter signed by the WEBB COUNTY's Risk Manager, which shall become a part of this Contract for all purposes.

11.15 As they apply to the limits required by WEBB COUNTY, WEBB COUNTY shall be entitled, upon request and without expense, to receive certified copies of all insurance policies, declaration pages and all required endorsements associated with this Work. Contractor shall be required to comply with any such requests and shall submit requested documents to WEBB COUNTY at the address provided below within ten (10) calendar days. Contractor shall pay any and all costs incurred resulting from provision of said documents to WEBB COUNTY.



**WEBB COUNTY**  
Attn: Risk Manager  
1110 Washington St. Suite 204  
Laredo, Texas 78040

11.16 Contractor agrees that with respect to the above required insurance, all insurance policies are to contain or be endorsed to contain the following provisions:

- 11.1.6.1 Name WEBB COUNTY, its officers, officials, employees, volunteers, and elected representatives as additional insureds on a primary and non-contributory basis by endorsement, with respect to operations and activities of, or on behalf of, the named insured performing under this Contract with WEBB COUNTY, with the exception of the workers' compensation and professional liability policies;
- 11.1.6.2 Provide for an endorsement reflecting the "other insurance" clause shall not apply to the WEBB COUNTY where WEBB COUNTY is an additional insured shown on the policy;
- 11.1.6.3 All required policies, including but not limited to Workers' compensation, employers' liability, general liability and automobile liability policies, shall provide a waiver of subrogation in favor of WEBB COUNTY.
- 11.1.6.4 Provide thirty (30) calendar days advance written notice directly to WEBB COUNTY, at the address cited above, of any suspension, cancellation, material change or non-renewal in coverage of Contractor's insurance policy/policies associated with this Work and not less than thirty (30) calendar days in advance notice for Contractor's nonpayment of premium(s).

11.17 Within five (5) calendar days of a suspension, cancellation, material change or non-renewal of insurance coverage associated with this Work, Contractor shall provide a replacement Certificate(s) of Insurance and applicable endorsement(s) to WEBB COUNTY. WEBB COUNTY shall have the option to suspend Contractor's performance should there be a lapse in coverage at any time during this contract. Failure to provide and to maintain the required insurance shall constitute a material breach of this Contract.

11.18 In addition to any other remedies WEBB COUNTY may have upon Contractor's failure to provide and maintain any insurance and/or policy endorsements to the extent and within the time herein required, WEBB COUNTY shall have the right to order Contractor to stop work hereunder and/or withhold any payment(s) which become due to Contractor hereunder until Contractor demonstrates compliance with the insurance requirements hereof.

11.19 Nothing contained herein shall be construed as limiting in any way the extent to which Contractor may be held responsible for payments of damages to persons or property resulting from Contractor's or its Subcontractors' performance of the Work covered under this Contract.

11.1.10 Contractor accepts and agrees Contractor's insurance shall be deemed primary and non-contributory, with respect to any insurance or self-insurance carried by WEBB COUNTY, for

liability arising out of Contractor's operations under this Contract.

11.1.11 Contractor understands, accepts and agrees the insurance required of Contractor by this Contract is in addition to and separate from any other obligation contained in this Contract and no claim or action by or on behalf of WEBB COUNTY shall be limited to insurance coverage provided.

11.1.12 Contractor and any of Contractor's Subcontractors are responsible for any and all damage to their own equipment and/or property unless caused by others, including WEBB COUNTY. If caused by others, then Contractor may recover said damages from those causing same..

11.1.13 Without limiting any of the other obligations or liabilities of Contractor under the Contract Documents, Contractor shall purchase and maintain, during the term of the Contract and at Contractor's own expense, the minimum liability insurance coverage described below with insurance companies duly authorized or approved to do business in the State of Texas and otherwise satisfactory to WEBB COUNTY. Contractor also shall require each Subcontractor performing work under the Contract, at Subcontractor's own expense, to maintain levels of insurance necessary and appropriate for the Work performed during the term of the Contract, said levels of insurance comply with all applicable laws. Subcontractor's liability insurance shall name Contractor, WEBB COUNTY and Design Consultant as additional insureds by using endorsement CG 20 26 or broader. Certificates of insurance complying with the requirements prescribed in **Section 11.1.3** herein shall show the existence of each policy, together with copies of all policy endorsements showing WEBB COUNTY and Design Consultant as an additional insured, and shall be delivered to WEBB COUNTY before any Work is started. Contractor promptly shall furnish, upon the request of and without expense to WEBB COUNTY, a certified copy of each policy required, including all endorsements, which shall indicate:

11.1.14 Workers' Compensation, with statutory limits, with the policy endorsed to provide a waiver of subrogation as to WEBB COUNTY; Employer's Liability Insurance of not less than \$500,000.00 for each accident, \$500,000.00 disease for each employee and \$500,000.00 disease policy limit;

11.1.15 Commercial General Liability Insurance, Personal Injury Liability, Independent Contractor's Liability and Products and Completed Operations and Contractual Liability covering, but not limited to, the liability assumed under the indemnification provisions of this Contract, fully insuring Contractor's (and/or Subcontractor's) liability for injury to or death of WEBB COUNTY's employees and all third parties, and for damage to property of third parties, with a combined bodily injury (including death) and property damage minimum limit of \$1,000,000.00 per occurrence, \$2,000,000.00 annual general aggregate and \$2,000,000 Products and Completed Operations aggregate. WEBB COUNTY shall be named as additional insured by using endorsement CG 20 26 or broader. The general liability policy shall include coverage extended to apply to completed operations and XCU hazards. The Completed Operations coverage must be maintained for a minimum of two (2) years after final completion and acceptance of the Work, with evidence of same filed with WEBB COUNTY. The policy shall include an endorsement CG2503 amendment of limits (designated project or premises) in order to extend the policy's limits specifically to the Project in question.

11.116 Business Automobile Liability Insurance, covering owned, hired and non-owned vehicles, with a combined bodily injury (including death) and property damage minimum limit of \$1,000,000 per occurrence. Such insurance shall include coverage for loading and unloading hazards.

11.117 Five (5) calendar days prior to a suspension, cancellation material or non-renewal of any required line of insurance coverage, Contractor shall provide WEBB COUNTY a replacement certificate of insurance with all applicable endorsements included. WEBB COUNTY shall have the option to suspend Contractor.

11.118 If any insurance company providing insurance coverage(s) required under the Contract Documents for Contractor becomes insolvent or becomes the subject of any rehabilitation, conservatorship, liquidation or similar proceeding, Contractor immediately shall procure, upon first notice to Contractor or WEBB COUNTY of such occurrence and without cost to WEBB COUNTY, replacement insurance coverage before continuing the performance of the Work at the Project. Any failure to provide such replacement insurance coverage shall constitute a material breach of the Contract.

## 11.2 PROPERTY INSURANCE

11.21 As stated in Section 11.1 Contractor shall obtain at its expense and maintain throughout the duration of the Project, All-Risk Builder's Risk Insurance, if the Project involves complete construction of a new building, or an All-Risk Installation Floater policy, if the Project involves materials and supplies needed for additions to, renovations or remodeling of an existing building. Coverage on either policy shall be All-Risk, including, but not limited to, Fire, Extended Coverage, Vandalism and Malicious Mischief, Flood (if located in a flood zone) and Theft, in an amount equal to one hundred percent (100%) of the insurable value of the Project for the Installation Floater policy, and one hundred percent (100%) of the replacement cost of the Project for the Builder's Risk policy. If an Installation Floater policy is provided, WEBB COUNTY shall be shown as a Joint Named Insured with respect to the Project. If a Builder's Risk policy is provided, the policy shall be written on a Completed Value Form, including materials delivered and labor performed for the Project. This policy shall be in the name of Contractor and naming WEBB COUNTY, Design Consultant and Subcontractors, as well as any Sub-Subcontractors, as additional insureds as their interests may appear. The policy shall have endorsements as follows:

11.22 This insurance shall be specific as to coverage and not contributing insurance with any permanent insurance maintained on the property.

11.23 WEBB COUNTY is to be named as Loss Payee as respects any loss under applicable property insurance.

11.24 BOILER AND MACHINERY INSURANCE. If applicable, WEBB COUNTY shall purchase and maintain Boiler and Machinery Insurance required by the Contract Documents or by law, which specifically shall cover such insured objects during

installation and until final acceptance by WEBB COUNTY. This insurance shall include the interests of WEBB COUNTY, Contractor, Subcontractors and Sub-Subcontractors in the Work, and WEBB COUNTY and Contractor shall be named insureds.

- 1125 LOSS OF USE INSURANCE. WEBB COUNTY, at WEBB COUNTY's option, may purchase and maintain such insurance as shall insure WEBB COUNTY against loss of use of WEBB COUNTY's property due to fire or other hazards, however caused.
- 1126 Contractor shall provide to Design Consultant for delivery to WEBB COUNTY a Certificate of Insurance evidencing all property insurance policies procured under this Section 11.2 and all endorsements thereto, before any exposure to loss may occur.
- 1127 Partial occupancy or use in accordance with Section 9.8.1 herein shall not commence until the insurance company/companies providing property insurance have consented to such partial occupancy or use by endorsement or otherwise. WEBB COUNTY and Contractor shall take reasonable steps to obtain consent of the insurance company/companies and shall take no action without mutual written consent with respect to partial occupancy or use that would cause cancellation, lapse or reduction of insurance.
- 1128 Contractor shall take all necessary precautions to ensure no damage shall result from operations to private or public property. All damages shall be repaired or replaced by Contractor at no additional cost to WEBB COUNTY.

### **11.3 PERFORMANCE BONDS AND PAYMENT BONDS**

11.3.1 Subject to the provisions of Section 11.3.2 herein, Contractor shall, with the execution and delivery of the Contract, furnish and file with WEBB COUNTY, in the amounts required in this Article XI, the Surety Bonds described in Section 11.3.1.1 and Section 11.3.1.2 herein, with said Surety Bonds in accordance with the provisions of Chapter 2253, Texas Government Code, as amended. Each Surety Bond shall be signed by Contractor, as the Principal, as well as by an established corporate surety bonding company as surety, meeting the requirements of Section 11.3.3 herein and approved by WEBB COUNTY. The Surety Bonds shall be accompanied by an appropriate Power-of-Authority clearly establishing the extent and limitations of the authority of each signer to so sign and shall include:

11.3.1.1 **PERFORMANCE BOND.** A good and sufficient Performance Bond in an amount equal to one hundred percent (100%) of the total Contract Sum, guaranteeing the full and faithful execution of the Work and performance of the Contract in accordance with Plans, Specifications and all other Contract Documents, including any extensions thereof, for the protection of WEBB COUNTY. This Performance Bond also shall provide for the repair and maintenance of all defects due to faulty materials and workmanship that appear within a period of one (1) year from the date of final Completion or acceptance of the Work by WEBB COUNTY, or lesser or longer periods as otherwise may be designated in the Contract Documents.

11.3.1.2 PAYMENT BOND. A good and sufficient Payment Bond in an amount equal to 100% of the total Contract Sum, guaranteeing the full and prompt payment of all claimants supplying labor or materials in the prosecution of the Work provided for in the Contract, and for the use and protection of each claimant.

11.3.2 If the Contract Sum, including WEBB COUNTY -accepted Alternates and allowances, if any, is greater than \$100,000.00, a Payment Bond and a Performance Bond equaling one hundred percent (100%) of the Contract Sum are mandatory and shall be provided by Contractor. If the Contract Sum is greater than \$50,000 but less than or equal to \$100,000, only a Payment Bond equaling one hundred percent (100%) of the Contract amount is mandatory; provided, however, Contractor also may elect to furnish a Performance Bond in the same amount if Contractor so chooses. If the Contract Sum is less than or equal to \$25,000, Contractor may elect not to provide Performance and Payment Bonds; provided, in such event, no money shall be paid by WEBB COUNTY to Contractor until Final Completion of all Work. If Contractor elects to provide the required Performance Bond and Payment Bond, the Contract Sum shall be payable to Contractor through progress payments in accordance with these General Conditions.

11.3.3 No surety shall be accepted by WEBB COUNTY that is in default, delinquent on any bonds or that is a party to any litigation against WEBB COUNTY. All bonds shall be made and executed on WEBB COUNTY's standard forms, shall be approved by WEBB COUNTY and shall be executed by not less than one (1) corporate surety that is authorized and admitted to do business in the State of Texas, is licensed by the State of Texas to issue surety bonds, is listed in the most current United States Department of the Treasury List of Acceptable Sureties and is otherwise acceptable to WEBB COUNTY. Each bond shall be executed by Contractor and the surety and shall specify that legal venue for enforcement of each bond exclusively shall lie in Webb County, Texas. Each surety shall designate an agent resident in Webb County, Texas to which any requisite statutory notices may be delivered and on which service of process may be had in matters arising out of the suretyship.

11.3.4 The person or persons, partnership, company, firm, limited liability company, association, corporation or other business entity to whom the Contract is awarded shall, within ten (10) days after such award, sign the required Contract with WEBB COUNTY and provide the necessary surety bonds and evidence of insurance as required under the Contract Documents. No Contract shall be binding on WEBB COUNTY until:

11.3.4.1 it has been approved as to form by WEBB COUNTY's Attorney;

11.3.4.2 it has been executed by WEBB COUNTY's County Judge; the Payment Bond and Performance Bond and evidence of the required insurance have been furnished to WEBB COUNTY by Contractor, as required by the Contract Documents; and

11.3.4.3 a fully executed Contract has been delivered to Contractor (if required).

11.3.5 The failure of Contractor to execute the Contract (if required) and deliver the required Bonds and evidence of insurance within ten (10) days after the Contract is awarded, or as soon thereafter as WEBB COUNTY can assemble and deliver the Contract and by the time the WEBB COUNTY scheduled Pre-Construction meeting is held, shall, at WEBB COUNTY's option, constitute a material breach of Contractor's bid proposal and WEBB COUNTY may rescind the Contract award and collect or retain the proceeds of the bid security. By reason of the uncertainty of the market prices for materials and labor and it being impracticable and difficult to determine accurately the amount of damages occurring to WEBB COUNTY by reason of Contractor's failure to execute the Contract within ten (10) days and deliver bonds and insurance by the WEBB COUNTY scheduled Pre-Construction meeting, the filing of a bid proposal shall constitute an acceptance of this Section 11.3.5. In the event WEBB COUNTY should re-advertise for bids, the defaulting Contractor shall not be eligible to bid and the lowest responsible bid obtained in the re-advertisement shall be the bid referred to in this Section 11.3.

#### 11.4 'UMBRELLA' LIABILITY INSURANCE.

Contractor shall obtain, pay for and maintain Umbrella Liability Insurance during the Contract term, insuring Contractor for an amount of not less than \$5,000,000 per occurrence combined limit Bodily Injury (including death) and Property Damage, that follows form and applies in excess of the primary coverage required hereinabove. WEBB COUNTY and Design Consultant shall be named as additional insureds using endorsement CG 20 26 or broader. In addition to the general aggregate the Umbrella Policy shall have a separate products/completed operations aggregate in the same amount as the occurrence limit. The Umbrella Liability Insurance policy shall provide "drop down" coverage, where the underlying primary insurance coverage limits are insufficient or exhausted.

#### 11.5 POLICY ENDORSEMENTS AND SPECIAL CONDITIONS

11.5.1 Each insurance policy to be furnished by Contractor shall address the following required provisions within the certificate of insurance, which shall be reflected in the body of the insurance contract and/or by endorsement to the policy:

11.5.1.1 WEBB COUNTY and Design Consultant shall be named as additional insureds on all liability coverages, using endorsement CG 20 26 or broader. When WEBB COUNTY employs a Construction Manager on the Project, Contractor and Subcontractor(s) shall include the Construction Manager on all liability insurance policies to the same extent as WEBB COUNTY and Design Consultant are required to be named as additional insureds. The additional insured shall be on a primary and non-contributory basis.

11.5.1.2 Within five (5) calendar days of a suspension, cancellation, material change or non-renewal of any required line of insurance coverage, Contractor shall provide WEBB COUNTY a replacement certificate of insurance with all applicable endorsements included. WEBB COUNTY shall have the option to suspend Contractor's performance should there be a lapse in coverage at any

time during the Contract.

- 11.5.1.3 The terms "Owner," or "WEBB COUNTY" shall include all authorities, boards, bureaus, commissions, divisions, departments and offices of WEBB COUNTY and the individual members, employees and agents thereof in their official capacities, while acting on behalf of WEBB COUNTY.
- 11.5.1.4 The policy phrase or clause "Other Insurance" shall not apply to WEBB COUNTY where WEBB COUNTY is an additional insured on the policy. The required insurance coverage furnished by Contractor shall be the primary insurance for all purposes for the Project, as well as the primary and non-contributory insurance for the additional insureds named in the required policies.
- 11.5.1.5 All provisions of the Contract Documents concerning liability, duty and standard of care, together with the indemnification provision, shall, to the maximum extent allowable in the insurance market, be underwritten with contractual liability coverage(s) sufficient to include such obligations with the applicable liability policies.

11.5.2 Concerning the insurance to be furnished by the Contractor, it is a condition precedent to acceptability which:

- 11.5.2.1 All policies must comply with the applicable requirements and special provisions of this Article XI.
- 11.5.2.2 Any policy evidenced by a Certificate of Insurance shall not be subject to limitations, conditions or restrictions deemed inconsistent with the intent of the insurance requirements set forth herein, and WEBB COUNTY's decision regarding whether any policy contains such provisions and contrary to this requirement shall be final.
- 11.5.2.3 All policies required are to be written through companies duly authorized and approved to transact that class of insurance in the State of Texas and that otherwise are acceptable to WEBB COUNTY.

11.5.3 Contractor agrees to the following special provisions:

- 11.5.3.1 Contractor hereby waives subrogation rights for loss or damage to the extent same are covered by insurance. Insurers shall have no right of recovery or subrogation against WEBB COUNTY, it being the intention that the insurance policies shall protect the Parties to the Contract and be primary coverage for all losses covered by the policies. This waiver of subrogation shall be included, by endorsement or otherwise, as a provision of all policies required under this Article XI.



- 11.5.3.2 Insurance companies issuing the insurance policies and Contractor shall have no recourse whatsoever against WEBB COUNTY for payment of any premiums or assessments for any deductibles, as all such premiums and assessments solely are the responsibility and risk of Contractor.
- 11.5.3.3 Approval, disapproval or failure to act by WEBB COUNTY, regarding any insurance supplied by Contractor or any Subcontractor(s), shall not relieve Contractor of any responsibility or liability for damage or accidents as set forth in the Contract Documents. The bankruptcy, insolvency or denial of liability of or by Contractor's insurance company shall likewise not exonerate or relieve Contractor from liability.
- 11.5.3.4 WEBB COUNTY reserves the right to review the insurance requirements of this Article XI during the effective period of this Contract and to adjust insurance coverage and insurance limits when deemed necessary and prudent by WEBB COUNTY's Risk Management Division, based upon changes in statutory law, court decisions or the claims history of Contractor and Subcontractors. Contractor agrees to make any reasonable request for deletion, revision or modification of particular policy terms, conditions, limitations or exclusions, except where policy provisions are established by law or regulation binding upon either Party to this Contract or upon the underwriter of any such policy provisions. Upon request by WEBB COUNTY, Contractor shall exercise reasonable efforts to accomplish such changes in policy coverage.
- 11.5.3.5 No special payments shall be made for any insurance policies that Contractor and Subcontractors are required to carry. Except as provided in Section 11.5.3.4 herein, all amounts payable regarding the insurance policies required under the Contract Documents are included in the Contract Sum.
- 11.5.3.6 Any insurance policies required under this Article XI may be written in combination with any of the other policies, where legally permitted, but none of the specified limits neither may be lowered or otherwise negatively impacted by doing so, nor may any of the requirements or special provisions of this Article XI be limited or circumvented by doing so.

## **ARTICLE XII. INSPECTING, UNCOVERING AND CORRECTING OF WORK**

### **121 INSPECTING WORK**

WEBB COUNTY and Design Consultant shall have authority to reject Work that does not conform to the Contract Documents. Whenever WEBB COUNTY or Design Consultant considers it necessary or advisable, WEBB COUNTY and/or Design Consultant shall have authority to require inspection or testing of the Work in accordance with this **Article XII**, whether or not such Work is fabricated, installed or completed.

## 122 UNCOVERING WORK

12.2.1 If a portion of the Work is covered, concealed and/or obstructed, contrary to WEBB COUNTY's or Design Consultant's requirements specifically expressed in the Contract Documents, it must be uncovered for WEBB COUNTY's or Design Consultant's inspection and properly be replaced at Contractor's expense without any change in the Contract Time or Sum.

12.2.2 If a portion of the Work has been covered, concealed and/or obstructed and Design Consultant or WEBB COUNTY has not inspected the Work prior to its being covered, concealed and/or obstructed, WEBB COUNTY and Design Consultant retain the right to inspect such Work and, when directed by WEBB COUNTY, Contractor shall uncover it. If said Work is found to be in accordance with the Contract Documents, the costs for uncovering and replacement shall, by appropriate Change Order, be paid by WEBB COUNTY. If such Work uncovered is found to not be in accordance with the Contract Documents, Contractor shall pay all costs associated with the uncovering, correction and replacement of the Work, unless the condition found was caused by WEBB COUNTY or WEBB COUNTY's separate contractor, in which event WEBB COUNTY shall be responsible for payment of actual costs incurred by Contractor.

## 123 CORRECTING WORK

12.3.1 Contractor promptly shall correct any Work rejected by WEBB COUNTY or Design Consultant as failing to conform to the requirements of the Contract Documents, whether inspected before or after Substantial Completion and whether or not fabricated, installed or completed. Contractor shall bear costs of correcting such rejected Work, along with all costs for additional testing, inspections and compensation for Design Consultant's services and expenses made necessary thereby.

12.3.2 In addition to Contractor's warranty obligations, if any of the Work is found to be defective or nonconforming with the requirements of the Contract Documents, including, but not limited to these General Conditions, Contractor shall correct it promptly after receipt of written notice from WEBB COUNTY or Design Consultant to correct unless WEBB COUNTY previously has given Contractor a written acceptance or waiver of the defect or nonconformity. Contractor's obligation to correct defective or nonconforming Work remains in effect for:

- 12.3.2.1 one (1) year after the date of Substantial Completion of the Work or designated portion of the Work;
- 12.3.2.2 one (1) year after the date for commencement of warranties established by agreement in connection with partial occupancy under **Section 9.8.1** hereto; or
- 12.3.2.3 the stipulated duration of any applicable special warranty required by the Contract Documents.

12.3.3 The one (1) year period, described in **Section 12.3.2.1**, **Section 12.3.2.2** and **Section 12.3.2.3** herein, shall be extended, with respect to portions of the Work first performed after Substantial Completion, by the period of time between Substantial Completion and the actual completion of the Work.

12.3.4 Contractor shall remove from the Project Site portions of the Work which are not in accordance with the requirements of the Contract Documents and are neither corrected by Contractor nor accepted by WEBB COUNTY.

12.3.5 If Contractor fails to correct any defective or nonconforming Work within what WEBB COUNTY deems a reasonable time after WEBB COUNTY or Design Consultant gives written notice of rejection to Contractor, WEBB COUNTY may correct the defective or nonconforming Work in accordance with this **Section 12.3**. If Contractor promptly does not proceed with correction of any defective or nonconforming Work within a reasonable time fixed by written notice from WEBB COUNTY or Design Consultant, WEBB COUNTY may remove or replace the defective or nonconforming Work and store the salvageable materials or equipment at Contractor's expense. If Contractor does not pay the costs of removal and storage within ten (10) calendar days after written notice by WEBB COUNTY or Design Consultant, WEBB COUNTY may, upon ten (10) additional calendar days written notice, sell the materials and equipment at auction or at private sale and shall account to Contractor for the proceeds, after deducting all costs and damages that should have been borne by Contractor to correct the defective work, including all compensation for Design Consultant's services and expenses made necessary as a result of the sale, removal and storage. If the proceeds of sale do not cover the costs that Contractor should have borne, the Contract Sum shall be reduced by the deficiency. If payments due to Contractor then or thereafter are not sufficient to cover the deficiency, Contractor shall pay the difference to WEBB COUNTY.

12.3.6 Contractor shall bear the cost of correcting destroyed or damaged construction of WEBB COUNTY or WEBB COUNTY's separate contractors, whether the construction is completed or partially completed, caused by Contractor's correction or removal of Work which is not in accordance with the requirements of the Contract Documents.

12.3.7 After Substantial Completion, WEBB COUNTY'S only remedy against Contractor is for defective Work under Contractor's one (1) year Warranty and for breach thereof or within two (2) from Substantial Completion for latent defects.

12.3.8 Any Work repaired or replaced, pursuant to this **Article XII**, shall be subject to the provisions of **Article XII** to the same extent as Work originally performed or installed.

## **12.4 ACCEPTANCE OF NONCONFORMING WORK**

WEBB COUNTY may, in WEBB COUNTY's sole discretion, accept Work that is not in accordance with the requirements of the Contract Documents instead of requiring its removal and correction. Upon that occurrence, the Contract Sum shall be reduced as appropriate and equitable, as solely determined by WEBB COUNTY. Any adjustment shall be accomplished whether or not final payment has been made.

## **ARTICLE XIII. COMPLETION OF THE CONTRACT; TERMINATION; TEMPORARY SUSPENSION**

### **13.1 FINAL COMPLETION OF CONTRACT**

The Contract shall be considered completed, except as provided in any warranty or maintenance stipulations, bond or by law, when all the Work has been finally completed, a final inspection is made by WEBB COUNTY and Design Consultant and final acceptance and final payment is made by WEBB COUNTY.

### **13.2 WARRANTY FULFILLMENT**

Prior to the expiration of the specified warranty period provided for in the Contract Documents, WEBB COUNTY or Design Consultant shall make a detailed inspection of the Work and shall advise Contractor and Contractor's Surety of the items that require correction. WEBB COUNTY or Design Consultant shall make a subsequent inspection and, if the corrections have been properly performed, WEBB COUNTY shall issue a letter of release on the maintenance obligations to Contractor. If, for any reason, Contractor has not made the required corrections before the expiration of the warranty period, the warranty provisions as provided for in the Contract Documents shall remain in effect until the corrections have properly been performed and a letter of release from WEBB COUNTY to Contractor is issued.

### **13.3 TERMINATION BY WEBB COUNTY FOR CAUSE**

13.3.1 Notwithstanding any other provision of these General Conditions, the Work or any portion of the Work may be terminated immediately by WEBB COUNTY for any good material cause after giving seven (7) calendar days advance written notice and a reasonable opportunity to cure to Contractor, including but not limited to the following causes:

- 13.3.1.1 Failure or refusal of Contractor to start the Work within ten (10) calendar days after the date of the written Notice to Proceed is issued by WEBB COUNTY to Contractor commence Work.
- 13.3.1.2 A reasonable belief of WEBB COUNTY or Design Consultant that the progress of the Work being made by Contractor is insufficient to complete the Work within the specified Contract time or the Contract time as may have been extended by Change Order, Field Directive or other approved manner of extension of the contract time.
- 13.3.1.3 Failure or refusal of Contractor to provide sufficient and proper equipment or construction forces properly to execute the Work in a timely manner.
- 13.3.1.4 A reasonable belief Contractor has abandoned the Work.
- 13.3.1.5 A reasonable belief Contractor has become insolvent, bankrupt, or otherwise is financially unable to carry on the Work.
- 13.3.1.6 Failure or refusal on the part of Contractor to observe any material requirements of

the Contract Documents or to comply with any written orders given by WEBB COUNTY or Design Consultant, as provided for in the Contract Documents.

- 13.3.1.7 Failure or refusal of Contractor promptly to correct any defects in materials or workmanship, or defects of any nature of Contractor's Work, the correction of which has been directed to Contractor in writing by WEBB COUNTY or Design Consultant.
- 13.3.1.8 A reasonable belief by WEBB COUNTY collusion exists or has occurred for the purpose of illegally procuring the contract or a Subcontractor, or that a fraud is being perpetrated on WEBB COUNTY in connection with the construction of Work under the Contract.
- 13.3.1.9 Repeated and flagrant violation of safe working procedures.

1332 When the Work or any portion of the Work is terminated for any of the causes itemized in **Section 13.3.1** herein, or for any other cause except termination for convenience pursuant to **Section 13.3.6** herein, Contractor shall, as of the date specified by WEBB COUNTY, immediately discontinue the Work or portion of the Work as WEBB COUNTY shall designate, whereupon the Surety shall, within fifteen (15) calendar days after the written Notice of Termination by WEBB COUNTY For Cause has been served upon Contractor and the Surety or its authorized agents, assume the obligations of Contractor for the Work or that portion of the Work which WEBB COUNTY has ordered Contractor to discontinue and Surety may:

- 13.3.2.1 perform the Work with forces employed by the surety;
- 13.3.2.2 with the written consent of WEBB COUNTY, tender a replacement Contractor to take over and perform the Work, in which event the Surety shall be responsible for and pay the amount of any costs required to be incurred or the completion of the Work that are in excess of the amount of funds remaining under the Contract as of the time of the termination; or
- 13.3.2.3 with the written consent of WEBB COUNTY, tender and pay to WEBB COUNTY in settlement the amount of money necessary to finish the balance of uncompleted Work under the Contract, correct existing defective or nonconforming work and compensate WEBB COUNTY for any other recoverable (pursuant to the Contract Documents) loss sustained as a result of Contractor's default.

In the event of Termination by WEBB COUNTY For Cause involving **Article 13.3.2.1** and/or **Article 13.3.2.2**, the Surety shall assume Contractor's place in all respects and the amount of funds remaining and unpaid under the Contract shall be paid by WEBB COUNTY for all Work performed by the Surety or the replacement contractor in accordance with the terms of the Contract Documents, subject to any rights of WEBB COUNTY to deduct any and all costs, damages (liquidated or actual) WEBB COUNTY incurred including, but not limited to, any and all additional fees and expenses of Design Consultant and any attorneys' fees WEBB COUNTY

incurs as a result of Contractor's default and subsequent termination.

1333 The balance of the Contract Sum remaining at the time of Contractor's default and subsequent termination shall become due and payable to the Surety as the Work progresses, subject to all of the terms, covenants and conditions of the Contract Documents. If the Surety does not, within the time specified in **Section 13.3.2** herein, exercise its obligation to assume the obligations of the Contract, or that portion of the Work which WEBB COUNTY has ordered Contractor to discontinue, then WEBB COUNTY shall have the power to complete the Work by contract or otherwise, as WEBB COUNTY may deem necessary and elect.

1334 All expenses incurred by WEBB COUNTY to complete the Work shall be deducted by WEBB COUNTY out of the balance of the Contract Sum remaining unpaid to or unearned by Contractor. Contractor and the Surety shall be liable to WEBB COUNTY for any costs incurred in excess of the balance of the Contract Sum for the completion and correction of the Work, and for any other reasonable and necessary: costs, damages, expenses (including, but not limited to, additional fees of Design Consultant and attorney's fees) and liquidated or actual damages incurred as a result of the termination.

1335 WEBB COUNTY shall not be required to obtain the lowest bid for the Work of completing the Contract, as described in **Section 13.3.3** herein, but the expenses to be deducted from the Contract Sum shall be the actual, reasonable, and necessary cost of such Work and the other damages, as provided in **Section 13.3.3** herein. In case WEBB COUNTY's costs and damages are less than the sum which would have been payable under the Contract if the Work had been completed by Contractor pursuant to the Contract, then WEBB COUNTY is to pay Contractor (or the Surety, in the event of a complete Termination by WEBB COUNTY For Cause) the difference, provided that Contractor (or the Surety) shall not be entitled to any claim for damages or for loss of anticipated profits. In case such costs for completion and damages shall exceed the amount which would have been payable under the Contract if the Work had been completed by Contractor pursuant to the Contract, then Contractor and its Surety shall pay the amount of the excess to WEBB COUNTY immediately upon written notice from WEBB COUNTY to Contractor and/or the Surety for the excess amount owed. When only a particular part of the Work is being carried on by WEBB COUNTY, by contract or otherwise under the provisions of this Section, Contractor shall continue the remainder of the Work in conformity with the terms of the Contract and in such manner as not to hinder or interfere with the performance of workers employed and provided by WEBB COUNTY.

1336 The right to terminate this Contract for the convenience of WEBB COUNTY (including, but not limited to, non-appropriation of funding) expressly is retained by WEBB COUNTY. In the event of a termination for convenience by WEBB COUNTY, WEBB COUNTY shall, at least ten (10) calendar days in advance, deliver written notice of the termination for convenience to Contractor. Upon Contractor's receipt of such written notice, Contractor immediately shall cease the performance of the Work and shall take reasonable and appropriate action to secure and protect the Work then in place. Contractor shall then be paid by WEBB COUNTY, in accordance with the terms and provisions of the Contract Documents, an amount not to exceed the actual labor costs incurred, the actual cost of all materials installed and the actual cost of all materials stored at the Project site or away from the Project site, as approved in writing by WEBB COUNTY but not yet

paid for and which cannot be returned, plus applicable overhead, profit, and actual, reasonable and documented termination costs, if any, paid by Contractor in connection with the Work in place which is completed and in conformance with the Contract Documents up to the date of termination for convenience, less all amounts previously paid for the Work. No amount ever shall be paid to Contractor for lost or anticipated profits on any part of the Work not performed.

#### **13.4 TEMPORARY SUSPENSION OF THE WORK**

13.4.1 The Work or any portion of the Work may temporarily be suspended by WEBB COUNTY, for a time period not to exceed ninety (90) calendar days, immediately upon written notice to Contractor for any reason, including, but not limited to:

13.4.1.1 the causes described in **Section 13.3.1.1** through **Section 13.3.1.9** herein;

13.4.1.2 under other provisions in the Contract Documents that require or permit temporary suspension of the Work;

13.4.1.3 situations where the Work is threatened by, contributes to or causes an immediate threat to public health, safety, or security; or

13.4.1.4 other unforeseen conditions or circumstances.

13.4.2 Contractor immediately shall resume the temporarily suspended Work when ordered in writing to do so by WEBB COUNTY. WEBB COUNTY shall not, under any circumstances, be liable for any claim of Contractor arising from a temporary suspension due to a cause described in **Section 13.4.1** herein; provided, however, that in the case of a temporary suspension for any of the reasons described under **Section 13.4.1.2** through **Section 13.4.1.4** herein, where Contractor is not a contributing cause of the suspension or where the provision of the Contract Documents in question does not specifically provide that the suspension is at no cost to WEBB COUNTY, WEBB COUNTY shall make an equitable adjustment for the following items, provided that a claim properly is made by Contractor under **Section 4.3** herein:

13.4.2.1 an equitable extension of the Contract Time, not to exceed the actual delay caused by the temporary suspension, as determined by WEBB COUNTY and Design Consultant;

13.4.2.2 an equitable adjustment to the Contract Sum for the actual, necessary and reasonable costs of properly protecting any Work finished or partially finished during the period of the temporary suspension; provided, however, that no payment of profit and/or overhead shall be allowed on top of these costs; and

13.4.2.3 if it becomes necessary to move equipment from the Project Site and then return it to the Project Site when the Work is ordered to be resumed, an equitable adjustment to the Contract Sum for the actual, necessary and reasonable cost of these moves; provided, however, that no adjustment to the Contract Sum shall be due if said equipment is moved to another Project site of WEBB COUNTY.



## ARTICLE XIV. MISCELLANEOUS PROVISIONS

### 141 GOVERNING LAW; COMPLIANCE WITH LAWS AND REGULATIONS

1411 This Contract shall be governed by the laws and case decisions of the State of Texas, without regard to conflict of law or choice of law principles of Texas or of any other state.

1412 This Contract is entered into subject to and controlled by all applicable laws, rules and regulations of the State of Texas and the Government of the United States of America. Contractor shall, during the performance of the Work, comply with all applicable orders, codes and ordinances, as amended, and all applicable State of Texas and Federal laws, rules and regulations, as amended.

### 142 SUCCESSORS AND ASSIGNS.

WEBB COUNTY and Contractor respectively bind themselves, their partners, successors, assigns and legal representatives to the promises, covenants, terms, conditions and obligations contained in the Contract Documents. Contractor shall not assign, transfer or convey its interest or rights in the Contract, in part or as a whole, without the written consent of WEBB COUNTY. If Contractor attempts to make an assignment, transfer or conveyance without WEBB COUNTY's written consent, Contractor nevertheless shall remain legally responsible for all obligations under the Contract Documents. WEBB COUNTY shall not assign any portion of the Contract Sum due or to become due under this Contract without the written consent of Contractor, except where assignment is compelled by court order, other operation of law or the terms of these General Conditions.

### 143 WRITTEN NOTICE.

Any notice, payment, statement or demand required or permitted to be given under this Contract by either Party to the other may be effected by personal delivery in writing or by facsimile transmission, email or by mail, postage prepaid, or by overnight delivery to an officer, management level employee or other designated representative of either Party. Mailed or email notices shall be addressed to the Parties at an address designated by each Party, but each Party may change its address by written notice in accordance with this section. Certified mail notices shall be deemed received as of three (3) calendar days after mailing.

### 144 RIGHTS AND REMEDIES; NO WAIVER OF RIGHTS BY WEBB COUNTY

1441 The duties and obligations imposed on Contractor by the Contract Documents and the rights and remedies available to WEBB COUNTY under the Contract Documents shall be in addition to, and not a limitation of, any duties, obligations, rights and remedies otherwise imposed or made available by law, but as limited by the Contract Documents.

1442 No action or failure to act by either Party shall constitute a waiver of a right afforded to a Party under the Contract Documents, nor shall any action or failure to act by either Party constitute approval of or acquiescence in a breach of the Contract by the other Party except as may be specifically agreed in writing by Change Order, Amendment or Supplemental Agreement.

#### **145 INTEREST**

WEBB COUNTY shall not be liable for interest on any progress or final payment to be made under the Contract Documents, except as may be provided by the applicable provisions of the Prompt Payment Act, Chapter 2251, Texas Government Code, as amended, subject to **Article IX** of these General Conditions.

#### **146 INDEPENDENT MATERIALS TESTING AND INSPECTION**

In some circumstances, WEBB COUNTY shall retain, independent of Contractor, the inspection services, the testing of construction materials engineering and the verification testing services necessary for acceptance of the Project by WEBB COUNTY. Such Consultants shall be selected in accordance with Section 2254.004 of the Government Code. The professional services, duties and responsibilities of any independent Consultants shall be described in the agreements between WEBB COUNTY and those Consultants. The provision of inspection services by WEBB COUNTY shall be for Quality Assurance and shall not reduce or lessen Contractor's responsibility for the Work or its duty to establish and implement a thorough Quality Control Program to monitor the quality of construction and guard WEBB COUNTY against defects and deficiencies in the Work, as required herein. Contractor fully and solely is responsible for constructing the Project in strict accordance with the Construction Documents.

#### **147 OFFICERS OR EMPLOYEES OF WEBB COUNTY NOT TO HAVE FINANCIAL INTEREST IN ANY CONTRACT OF WEBB COUNTY.**

Contractor acknowledges the Purchasing Code of Ethics Policy of WEBB COUNTY and its Ethics Code prohibits a WEBB COUNTY elected official, officer or employee, from having a financial interest in any contract with WEBB COUNTY or any WEBB COUNTY agency, such as WEBB COUNTY owned utilities. An elected official, officer or employee has a "prohibited financial interest" in a contract with WEBB COUNTY or in the sale to WEBB COUNTY of land, materials, supplies or service, if any of the following individual(s) or entities is a Party to the contract or sale:

- (1) a WEBB COUNTY elected official, officer or employee; his parent, child or spouse;
- (2) a business entity in which the elected official, officer or employee, or his parent, child or spouse owns ten (10) percent or more of the voting stock or shares of the business entity, or ten (10) percent or more of the fair market value of the business entity;
- (3) a business entity in which any individual or entity above listed is a Subcontractor on a WEBB COUNTY contract, or
- (4) a partner or a parent or subsidiary business entity.

Pursuant to this **Article XIV**, Contractor warrants and certifies, and this Contract is made in reliance thereon, that it, its officers, employees and/or agents are neither officers nor employees of WEBB COUNTY. Except with WEBB COUNTY's low-bid contract awards, Contractor warrants

and certifies that it has tendered to WEBB COUNTY a Conflict of Interest Disclosure in compliance with WEBB COUNTY's Ethics Policy. Any violation of this **Section 14.7**, with the knowledge, express or implied, of the person, persons, partnership, company, firm, association or corporation contracting with WEBB COUNTY may render a Contract voidable by WEBB COUNTY Commissioners Court.

**148 Venue.**

This Contract is performed in Webb County, Texas, and if legal action is necessary to enforce this Contract, exclusive venue shall lie in the State Courts of Webb County, Texas.

**149 INDEPENDENT CONTRACTOR.**

In performing the Work under this Contract, the relationship between WEBB COUNTY and Contractor is Contractor is and shall remain an independent contractor. Contractor shall exercise independent judgment in performing the Work and solely is responsible for setting working hours, scheduling and/or prioritizing the Work flow and determining the means and methods of performing the Work, subject only to the requirements of the Contract Documents. No term or provision of this Contract shall be construed as making Contractor an agent, servant or employee of WEBB COUNTY or making Contractor or any of Contractor's employees, agents or servants eligible for the fringe benefits, such as retirement, insurance and worker's compensation which WEBB COUNTY provides to its employees.

**14.10 NON-DISCRIMINATION.**

As a Party to this Contract Contractor shall not discriminate on the basis of race, color, religion, national origin, sex, sexual orientation, gender identity, veteran status, age or disability, unless Contractor is exempted by state or federal law, or as otherwise established herein. Contractor covenants that it shall take all necessary actions to ensure that, in connection with any Work under this Contract, Contractor and its Subcontractor(s) shall not discriminate in the treatment or employment of any individual or groups of individuals on the grounds of race, color, religion, national origin, sex, sexual orientation, gender identity, veteran status, age or disability, either directly, indirectly or through contractual or other arrangements. Contractor also shall comply with all applicable requirements of the Americans with Disabilities Act, 42 U.S.C.A. §§12101-12213, as amended.

**14.11 GIFTS TO PUBLICSERVANTS**

**14.11.1** WEBB COUNTY may terminate this Contract immediately if Contractor has offered, conferred or agreed to confer any benefit on a WEBB COUNTY employee or official that the employee or official is prohibited by law from accepting.

**14.11.2** For purposes of this Article, "benefit" means anything reasonably regarded as pecuniary gain or pecuniary advantage, including benefit to any other person in whose welfare the beneficiary has a direct or substantial interest, but does not include a contribution or expenditure made and reported in accordance with law.

**14.11.3** Notwithstanding any other legal remedies, WEBB COUNTY may require Contractor to remove any employee of Contractor, a Subcontractor or any employee of a Subcontractor from the Project who has violated the restrictions of this **Article XIV** or any similar

State or Federal law and WEBB COUNTY may obtain reimbursement for any expenditures made to Contractor as a result of an improper offer, an agreement to confer or the conferring of a benefit to a WEBB COUNTY employee or official.

## **ARTICLE XV. AUDIT**

### **151 RIGHT TO AUDIT CONTRACTOR'S RECORDS.**

By execution of the Contract, Contractor grants WEBB COUNTY the right to audit, examine, inspect and/or copy, at WEBB COUNTY's election at all reasonable times during the term of this Contract and for a period of four (4) years following the completion or termination of the Work, all of Contractor's written and electronically stored records and billings relating to the performance of the Work under the Contract Documents. The audit, examination or inspection may be performed by a WEBB COUNTY designee, which may include its internal auditors or an outside representative engaged by WEBB COUNTY. Contractor agrees to retain its records for a minimum of ten (10) years following termination of the Contract, unless there is an ongoing dispute under the Contract, then, such retention period shall extend until final resolution of the dispute, with full access allowed to authorized representatives of WEBB COUNTY upon request, for purposes of evaluating compliance with this and other provisions of the Contract.

15.1.1 As used in these General Conditions, "Contractor written and electronically stored records" shall include any and all information, materials and data of every kind and character generated as a result of the work under this Contract. Example of Contractor written and electronically stored records include, but are not limited to: accounting data and reports, billings, books, general ledgers, cost ledgers, invoices, production sheets, documents, correspondences, meeting notes, subscriptions, agreements, purchase orders, leases, contracts, commitments, arrangements, notes, daily diaries, reports, drawings, receipts, vouchers, memoranda, time sheets, payroll records, policies, procedures, Subcontractor agreements, Supplier agreements, rental equipment proposals, federal and state tax filings for any issue in question, along with any and all other agreements, sources of information and matters that may, in WEBB COUNTY's sole judgment, have any bearing on or pertain to any matters, rights, duties or obligations under or covered by any Contract Documents.

15.1.2 WEBB COUNTY agrees that it shall exercise the right to audit, examine or inspect Contractor's records only during regular business hours. Contractor agrees to allow WEBB COUNTY and/or WEBB COUNTY's designee access to all of the Contractor's Records, Contractor's facilities and current or former employees of Contractor, deemed necessary by WEBB COUNTY or its designee(s), to perform such audit, inspection or examination. Contractor also agrees to provide adequate and appropriate work space necessary for WEBB COUNTY or its designees to conduct such audits, inspections or examinations.

15.1.3 Contractor shall include this **Article XV** in any Subcontractor, supplier or vendor contract.

## **ARTICLE XVI. ATTORNEY FEES**

The Parties hereto expressly agree, in the event of litigation, all Parties waive rights to payment of attorneys' fees that otherwise might be recoverable, pursuant to the Texas Civil Practice and

Remedies Code Chapter 38, Texas Local Government Code §271.153, the Prompt Payment Act, common law or any other provision for payment of attorney's fees.

### **Special Conditions for Horizontal Projects**

#### **3.2.5 Differing Site Conditions (Adds this Section 3.2.5 to GENERAL CONDITIONS FOR WEBB COUNTY CONSTRUCTION CONTRACTS)**

Contractor promptly shall, before such discovered conditions and/or structures are disturbed, notify WEBB COUNTY in writing of differing site conditions. Differing site conditions are defined as subsurface or latent physical and/or structural conditions at the Site differing materially from those indicated in the Plans, Specifications and other Contract Documents or newly discovered and previously unknown physical conditions at the Site of an unusual nature differing materially from those geophysical conditions typically encountered in the type Work being performed and generally being recognized as not indigenous to the Webb County, Texas environs.

WEBB COUNTY and/or Design Consultant promptly shall investigate the reported physical and/or structural conditions and shall determine whether or not the physical and/or structural conditions do materially so differ and thereby cause an increase or decrease in Contractor's cost of and/or time required for performance of any part of the Work under this Contract. In the event WEBB COUNTY reasonably determines the physical and/or structural conditions materially so differ, a negotiated and equitable adjustment shall be made to the Contract Time and/or Contract Sum and a Change Order promptly shall be issued by WEBB COUNTY.

- (1) No claim of Contractor under this **Section 3.2.5** shall be allowed unless Contractor has given the written notice called for above, prior to disturbing the discovered conditions and/or structures.
- (2) No Contract adjustment shall be allowed under this **Section 3.2.5** for any effects caused on unmodified Work.

#### **3.4.7 Material Testing (Added to Section 3.4.7 of GENERAL CONDITIONS FOR WEBB COUNTY CONSTRUCTION CONTRACTS)**

Materials not meeting Contract requirements or do not produce satisfactory results shall be rejected by WEBB COUNTY, unless WEBB COUNTY or Design Consultant approves corrective actions. Upon rejection, Contractor immediately shall remove and replace rejected materials. If Contractor does not comply with these requirements, WEBB COUNTY may remove and replace defective material and all costs incurred by WEBB COUNTY for testing, removal and replacement of rejected materials shall be deducted from any money due or owed to Contractor.

The source of supply of each of the materials shall be approved by WEBB COUNTY or Design Consultant before delivery is started and, at the option of WEBB COUNTY, may be sampled and tested by WEBB COUNTY for determining compliance with the governing Specifications before delivery is started. If it is found after trial sources of supply previously approved do not produce

uniform and satisfactory products, or if the product from any source proves unacceptable at any time, Contractor shall furnish materials from other approved sources. Only materials conforming to the requirements of the Contract documents and approved by WEBB COUNTY shall be used by Contractor in the work. All materials being used by Contractor are subject to inspection or test at any time during preparation or use. Any material which has been tested and accepted at the source of supply may be subjected to a check test after delivery and all materials which, when retested, do not meet the requirements of the Specifications shall be rejected. No material which, after approval, has in any way become unfit for use shall be used in the Work. However, once a material is tested and approved and the material was part of the Specifications and does not function as anticipated, then the removal and substitution will only be by Change Order with adjustments as to price and extended time.

If, for any reason, Contractor selects a material which is approved for use by WEBB COUNTY or Design Consultant by sampling, testing or other means, and Contractor decides to change to a different material requiring additional sampling and testing by WEBB COUNTY for approval, Contractor shall pay for any expense incurred by WEBB COUNTY for such additional sampling and testing and the costs incurred by WEBB COUNTY shall be deducted from any money due or owed to Contractor.

#### **7.2.5 Allowable Markups (Added to Section 7.2.5 of GENERAL CONDITIONS FOR WEBB COUNTY CONSTRUCTION CONTRACTS)**

Maximum allowable markups for Change Order pricing, when said pricing is not determined through unit prices, are established as follows:

##### **7.2.5.1 Labor**

Contractor shall be allowed the documented payroll rates for each hour laborers and foremen actually shall be engaged in the Work. Contractor shall be allowed to receive an additional twenty five percent (25%) as compensation, based on the total wages paid said laborers and foremen. No charge shall be made by Contractor for organization or overhead expenses. For costs of premiums on public liability and workers compensation insurance(s), Social Security and unemployment insurance taxes, an amount equal to fifty five percent (55%) of the sum of the labor cost, excluding the twenty five percent (25%) documented payroll rate compensation allowed herein, shall be the established maximum allowable labor burden cost. No charge for superintendence shall be made unless considered necessary and approved by WEBB COUNTY or a Change Order includes an extension of the Contract Time.

##### **7.2.5.2 Materials**

Contractor shall be allowed to receive the actual cost, including freight charges, for materials used on such Work, including an additional twenty five percent (25%) of the actual cost as compensation. When material invoices indicate an available discount, the actual cost shall be determined as the invoiced price less the available discount.

### 7.2.5.3 Equipment

For Contractor-owned machinery, trucks, power tools or other equipment, necessary for use on Change Order work, the Rental Rate Blue Book for Construction Equipment (hereafter referred to as "Blue Book") rate, as modified by the following, shall be used to establish Contractor's allowable hourly rental rates. Equipment used shall be at the rates in effect for each section of the Blue Book at the time of use. The following formula shall be used to compute the hourly rates:

$$H = \frac{M \times R1 \times R2}{176} + OP$$

Where H = Hourly Rate  
M = Monthly Rate  
R1 = Rate Adjustment Factor  
R2 = Regional Adjustment Factor  
OP = Operating Costs

If Contractor-owned machinery and/or equipment is not available and equipment is rented from an outside source, the hourly rate shall be established by dividing the actual invoice cost by the actual number of hours the equipment is involved in the Work. WEBB COUNTY reserves the right to limit the hourly rate to comparable Blue Book rates. When the invoice specifies the rental rate does not include fuel, lubricants, repairs and servicing, the Blue Book hourly operating cost shall be allowed to be added for each hour the equipment operates. The allowable equipment hourly rates shall be paid for each hour the equipment is involved in the Work and an additional maximum of fifteen percent (15%) may be added as compensation.

### 7.2.5.4 Subcontractor Markups

Contractor shall be allowed administrative cost only when extra Work, ordered by WEBB COUNTY, is performed by a Subcontractor or Subcontractors. The maximum allowable payment for administrative cost shall not exceed five percent (5%) of the total Subcontractor work. Off-duty peace officers and patrol cruisers shall be considered as Subcontractors, with regard to consideration of allowable contractor markups.

### 7.3.9 Field Work Directive Allowable Markups (Adds this Section 7.3.9 to GENERAL CONDITIONS FOR WEBB COUNTY CONSTRUCTION CONTRACTS)

Maximum allowable markups for Field Work Directives shall follow the allowable markups established in Section 7.2.5 herein.

### 8.2.2 Standby Equipment Costs (Added to Section 8.2.2 of GENERAL CONDITIONS FOR WEBB COUNTY CONSTRUCTION CONTRACTS)

Contractor shall be entitled to standby costs only when directed to standby in writing by WEBB COUNTY. Standby costs may include actual documented Project overhead costs of Contractor, consisting of administrative and supervisory expenses incurred at the Project Site. Standby equipment costs shall not be allowed during periods when the equipment would otherwise have been idle.

For Projects not affecting WEBB COUNTY traffic, a determination made solely by WEBB COUNTY on a project-by- project basis, Contractor is working a five (5) day work week, with a Working Day measured from sunrise to sundown Monday through Friday, no more than eight (8) hours of standby time shall be paid during a 24-hour day, no more than forty (40) hours shall be paid per week for standby time and no more than one hundred and seventy six (176) hours per month shall be paid of standby time. Standby time shall be computed at fifty percent (50%) of the rates found in the Rental Rate Blue Book for Construction Equipment and shall be calculated by dividing the monthly rate found in the Blue Book by 176, then multiplying that total by the regional adjustment factor and the rate adjustment factor. Operating costs shall not be charged by Contractor.

For Projects affecting WEBB COUNTY traffic, a determination made solely by WEBB COUNTY on a project-by-project basis, and Contractor is working a six (6) day work week, with a Working Day measured from sunrise to sundown Monday through Saturday, no more than eight (8) hours of standby time shall be paid during a 24-hour day, no more than forty-eight (48) hours shall be paid per week for standby time and no more than two hundred and eight (208) hours per month shall be paid of standby time. Standby time shall be computed at fifty percent (50%) of the rates found in the Rental Rate Blue Book for Construction Equipment and shall be calculated by dividing the monthly rate found in the Blue Book by 208, then multiplying that total by the regional adjustment factor and the rate adjustment factor. Operating costs shall not be charged by Contractor.

#### **10.11 Road Closures and Detour Routes (Adds this Section 10.11 to GENERAL CONDITIONS FOR WEBB COUNTY CONSTRUCTION CONTRACTS)**

Contractor shall not begin construction of the Project or close any streets until adequate barricades and detour signs have been provided, erected and maintained in accordance with the detour route and details shown on the Project Plans. Contractor shall notify WEBB COUNTY forty-eight (48) hours in advance of closing any street to through traffic. Local traffic shall be permitted the use of streets under construction whenever feasible.

#### **10.12 Use of WEBB COUNTY Streets (Adds this Section 10.12 to GENERAL CONDITIONS FOR WEBB COUNTY CONSTRUCTION CONTRACTS)**

Contractor shall confine the movements of all steel-tracked equipment to the limits of the Project Site and any such equipment shall not be allowed use of WEBB COUNTY's streets unless being transported on pneumatic-tired vehicles. Any damage to WEBB COUNTY's streets caused by Contractor and/or Contractor's equipment, either outside the limits of the Project site or within the limits of the Project site but not within the limits of the current phase then being constructed, shall be repaired by Contractor at its own expense and as prescribed by WEBB COUNTY's Specifications and direction. If Contractor cannot or refuses to repair street damage caused by Contractor and/or Contractor's equipment, WEBB COUNTY may perform the repairs and all expenses incurred by WEBB COUNTY in performing the repairs shall be deducted for any money due or owed to Contractor.



**10.13 Maintenance of Traffic (Adds this Section 10.13 to GENERAL CONDITIONS FOR WEBB COUNTY CONSTRUCTION CONTRACTS)**

In accordance with the approved traffic control plan and as specified in the Contract, Contractor shall:

- (1) keep existing roadways open to traffic or construct and maintain detours and temporary structures for safe public travel;
- (2) maintain the Work in passable condition, including proper drainage, to accommodate traffic;
- (3) provide and maintain temporary approaches and crossings of intersecting roadways in a safe and passable condition;
- (4) construct and maintain necessary access to adjoining property as shown in the Plans or as directed by WEBB COUNTY; and
- (5) furnish, install and maintain traffic control devices in accordance with the Contract. The cost of maintaining traffic shall be subsidiary to the Project and shall not directly be paid for by WEBB COUNTY, unless otherwise stated in the Plans and Specifications. WEBB COUNTY shall notify Contractor if Contractor fails to meet the above traffic requirements. WEBB COUNTY may perform the work necessary for compliance, but any action n by WEBB COUNTY shall not change the legal responsibilities of Contractor, as set forth in the Contract Documents. Any costs incurred by WEBB COUNTY for traffic maintenance shall be deducted from money due or owed to Contractor.

**10.14 Abatement and Mitigation of Excessive or Unnecessary Construction Noise (Adds this Section 10.14 to GENERAL CONDITIONS FOR WEBB COUNTY CONSTRUCTION CONTRACTS)**

Contractor shall ensure abatement and mitigation of excessive or unnecessary construction noise to the satisfaction of WEBB COUNTY and as prescribed by all applicable state and local laws.

**10.15 Incidental Work, Connections, and Passageways (Adds Section 10.15 to GENERAL CONDITIONS FOR WEBB COUNTY CONSTRUCTION CONTRACTS)**

Contractor shall perform all incidental Work necessary to complete and comply with this Contract including, but not limited to the following:

- (1) Contractor shall make and provide all suitable reconnections with existing improvements (generally excluding new connections with or relocation of utility services, unless specifically provided for otherwise in the Contract Documents) as are necessarily incidental to the proper completion of the Project;

- (2) Contractor shall provide passageways or leave open such thoroughfares in the Work Site as may be reasonably required by WEBB COUNTY; and

Contractor shall protect and guard same at its own risk and continuously shall maintain the Work Site in a clean, safe and workmanlike manner.

Bond No. \_\_\_\_\_

**STATUTORY PAYMENT BOND**  
**Pursuant to Vernon's Texas Government Code**  
**Title 10, Chapter 2253, as amended**

(Penalty of this Bond must be 100% of Contract Amount)

**THE STATE OF TEXAS**                   §  
   §   **KNOW ALL MEN BY THESE PRESENTS:**  
**COUNTY OF WEBB**                   §

That we, Anderson Columbia Co., Inc., as Principal, and \_\_\_\_\_, as Surety, are hereby held and firmly bound unto the Webb County, Texas, hereinafter called Obligee, for the sole use, benefit, and protection of all claimants supplying public work labor and material (as hereinafter defined) in the prosecution of the work provided for in the written Contract hereinafter referred to, in the penal sum of **Four Hundred Four Thousand Four Hundred Ninety Dollars (\$404,490.00)**, which is the full amount of Principal's contract with the named Obligee, for the payment of which sum the said Principal and Surety bind themselves, their heirs, executors, administrators, and successors, jointly and severally firmly by these presents.

**WHEREAS**, the Principal has entered into a written contract dated \_\_\_\_\_, 2023, with the Obligee named, to do and perform certain construction work as provided in said contract, to wit:

**Construction of West Meirs Street approximately one thousand three hundred seventy-five linear feet (1,375 LF) of first-time street utilizing six-inch (6 in.) base and two-inch (2 in.) HMAC and all associated appurtenances and constructing approximately one thousand two hundred linear feet (1,200 LF) of first-time street utilizing six-inch (6 in.) base and two-inch (2 in.) HMAC and all associated appurtenances in accordance with the attached Construction Plans / Specifications and general notes prepared by the Webb County Engineer's Office** and the related plans, specifications, general conditions, and other contract documents, all of which are by reference made a part hereof.

**NOW, THEREFORE, THE CONDITION OF THIS OBLIGATION IS SUCH** that if the Principal shall promptly make payment to all claimants supplying labor and material (as hereinafter defined) in the prosecution of the work provided for in said contract, the related plans, specifications, general conditions, and other contract documents, then this obligation shall be void, otherwise it shall remain in full force and effect.

**PROVIDED HOWEVER**, this Payment Bond is given and furnished by the Principal herein in compliance with Chapter 2253 of the Texas Government Code, as amended, and this Bond shall be solely for the protection and use of all claimants supplying public labor work or material (as hereinafter defined), and shall be solely for the protection and use of said claimants

who have a direct contractual relationship with the Principal herein, or a subcontractor (as hereinafter defined) to supply public work labor or material.

Surety, for value received, stipulates and agrees that not change, extension of time, or other waiver or amendment of the terms of the Contract or the work thereunder, or any change in the method or amount of payment stipulated to be made by Obligee under the Contract, shall relieve Surety of its obligations hereunder, and Surety hereby waives notice of any such change, extension of time, waiver or amendment of the terms of the Contract, shall relieve Surety of its obligations hereunder, and Surety hereby waives notice of any such change, extension of time, wavier or amendment of the terms of the Contract or to the work thereunder. The bond shall be automatically extended in time, without formal and separate amendment, to cover full and faithful performance of the Contract in the event of modification of the Contract, regardless of the length of time involved.

The undersigned corporate surety does by the execution of this Bond solemnly warrant and represent that it is duly authorized to do business in Texas.

IN WITNESS THEROF, Principal and Surety have signed and sealed this instrument on the \_\_\_\_\_ day of \_\_\_\_\_, 2023.

\_\_\_\_\_  
**Principal**

By: \_\_\_\_\_

Printed Name: \_\_\_\_\_

Title: \_\_\_\_\_

Approved as to form:

\_\_\_\_\_  
Attorney for Obligee

\_\_\_\_\_  
**Surety**

By: \_\_\_\_\_

Printed Name: \_\_\_\_\_

Title: \_\_\_\_\_

Mailing Address: \_\_\_\_\_

Physical Address: \_\_\_\_\_

Telephone No.: (\_\_\_\_) \_\_\_\_\_

**NOTE:**

- (1) "Prime Contractor" as used herein means a person, firm, or corporation that makes a public work contract with a governmental entity. Tex. Govt. Code §2253.001(3).
- (2) "Subcontractor" as used herein means a person, firm, or corporation that provides public work labor or material to fulfill an obligation to a prime contractor or to a contractor of the prime contractor for the performance and installation of any of the work required by a public work contract. Tex. Govt. Code §2253.001(9).
- (2) "Public work labor" as used herein means labor used directly to carry out a public work. Tex. Govt. Code §2253.001(5).
- (3) "Public work material" as used herein means: (A) material used, or ordered and delivered for use, directly to carry out a public work; (B) specially fabricated material; (C) reasonable rental and actual running repair costs for construction equipment used, or reasonably required and delivered for use, directly to carry out work at the project site; or (D) power, water, fuel, and lubricants used, or ordered and delivered for use, directly to carry out a public work. Tex. Govt. Code §2253.001(6).
- (4) "Specially fabricated material" as used herein means material ordered by a prime contractor or subcontractor that is: (A) specially fabricated for use in a public work; and (B) reasonably unsuitable for another use. Tex. Govt. Code §2253.001(8).
- (5) This Bond must be furnished before any work is commenced.
- (6) This Payment Bond is required for all public works contracts in excess of \$25,000 involving a contract for construction, alteration, or repair of any public building or the completion or prosecution of any public work.
- (7) The Surety must be a corporate surety duly authorized to do business in Texas.
- (8) This Payment Bond must be in the amount of the contract.
- (9) The Power of Attorney from the corporate surety should be attached to this Payment Bond.

**STAUTORY PERFORMANCE BOND**  
**Pursuant to Vernon's Texas Government Code**  
**Title 10, Chapter 2253, as amended**

(Penalty of this Bond must be 100% of Contract Amount)

THE STATE OF TEXAS           §  
  §    **KNOW ALL MEN BY THESE PRESENTS:**  
COUNTY OF WEBB            §

That we Anderson Columbia Co., Inc., as Principal, and \_\_\_\_\_, as Surety, are hereby held and firmly bound unto the Webb County, Texas, hereinafter called Obligee, in the penal sum of **Four Hundred Four Thousand Four Hundred Ninety Dollars (\$404,490.00)**, which is the full amount of Principal's contract with the named Obligee, for the payment of which sum the said Principal and Surety bind themselves, their heirs, executors, administrators, and successors, jointly and severally firmly by these presents.

**WHEREAS**, the principal has entered into a written contract dated \_\_\_\_\_, 2023, with Obligee named, to do and perform certain construction work as provided in said contract, to wit: **Construction of West Meirs Street approximately one thousand three hundred seventy-five linear feet (1,375 LF) of first-time street utilizing six-inch (6 in.) base and two-inch (2 in.) HMAC and all associated appurtenances and constructing approximately one thousand two hundred linear feet (1,200 LF) of first-time street utilizing six-inch (6 in.) base and two-inch (2 in.) HMAC and all associated appurtenances in accordance with the attached Construction Plans / Specifications and general notes prepared by the Webb County Engineer's Office** and the related plans, specifications, general conditions, and other contract documents, all of which are by reference made a part hereof.

**NOW, THEREFORE, THE CONDITIONS OF THIS OBLIGATION IS SUCH** that if the Principal shall faithfully perform all of the work in accordance with the plans, specifications, general conditions, and contract documents, and shall faithfully perform each, every, and all other obligations incumbent upon him under the terms of said written contract referred to, and shall fully indemnify and save harmless the Obligee from all costs, expense, and damage which it may suffer or incur because of the Principal's default, or failure to do so, then this Obligation shall be void, otherwise it shall remain in full force and effect.

In the event Principal shall default in the faithful performance of the work called for by said written contract, plans, specifications, and contract documents, the Surety shall, within 15 days of the determination of default (determined as provided in said contract, general conditions and contract documents), take over and assume completion of said contract, or within such 15-day period make

other arrangements satisfactory with the Obligee for completion of the contract, and said Surety shall become entitled thereupon to the payment or benefit of the balance of the contract price as the same matures according to its terms.

The Surety, for the protection of the Obligee herein, waives notice of, and hereby consents to any subsequent modification or alteration both in the work to be performed by the Principal, and the consequent price or sums to be paid by the Obligee, as well as any other change or amendment, addition, or deletion in the contract documents during the progress of the work, including, but not limited to, all extensions of time or other indulgences permitted the Principal.

Notwithstanding any other provision, the liability of the surety on this Bond shall never exceed the penal sum stated in the first paragraph.

This Performance Bond is given and furnished by the Principal herein in compliance with Chapter 2253 of the Texas Government Code, as amended, and all liabilities on this bond shall be determined in accordance with the provisions of this Chapter, to the same extent as if it were copied at length herein and is solely for the protection of the Obligee herein.

The undersigned corporate surety does, by the execution of this Bond, solemnly warrant and represent that it is duly authorized to do business in Texas.

**IN WITNESS THEREOF**, Principal and Surety have signed and sealed this instrument on the \_\_\_\_\_ day of \_\_\_\_\_, 2023.

\_\_\_\_\_  
**Principal**

\_\_\_\_\_  
**Surety**

By: \_\_\_\_\_

By: \_\_\_\_\_

Printed Name: \_\_\_\_\_

Printed Name: \_\_\_\_\_

Title: \_\_\_\_\_

Title: \_\_\_\_\_

Mailing address: \_\_\_\_\_  
\_\_\_\_\_

Physical Address: \_\_\_\_\_  
\_\_\_\_\_

Approved as to form:

\_\_\_\_\_  
Attorney for Obligee

Telephone No.: (\_\_\_\_) \_\_\_\_\_

**NOTE:**

- (1) This Performance Bond is required for all contracts in excess of \$100,000 involving a contract for construction, alteration, or repair of any public building or the completion or prosecution of any public work.
- (2) This bond must be payable to the awarding authority, United Independent School District, as the named Obligee, and it must be approved as to form by such awarding authority.
- (3) This Bond must be furnished before any work is commenced.
- (4) Surety must be a corporate surety duly authorized to do business in Texas.
- (5) This Performance Bond must be in the full amount of the contract which it secures.
- (6) Power of Attorney from corporate surety should be attached to this Performance Bond.



**NOTICE TO PROCEED**

Date: \_\_\_\_\_, 2023

To: Anderson Columbia Co., Inc.

**Project: "Pueblo Nuevo Street Improvement Project Contract CDV21-0485"**

In accordance with the construction contract dated \_\_\_\_\_, 2023 you are hereby authorized to proceed on \_\_\_\_\_, 2023.

Contract time is 60 calendar days. **Completion date for the project is approximately \_\_\_\_\_, 2023.**

WEBB COUNTY ENGINEERING DEPT.

\_\_\_\_\_  
Luis Perez Garcia, P.E.  
County Engineer

The above NOTICE TO PROCEED is hereby acknowledged by

\_\_\_\_\_

on this the \_\_\_\_\_ day of \_\_\_\_\_.

\_\_\_\_\_  
Authorized Signature

\_\_\_\_\_  
Typed Name:

Title: \_\_\_\_\_

## Federal Requirements

**The Following Federal provisions are applicable to this contract and Contractor is subject to compliance with the provisions under the Code of Federal Regulation Part 200 (Uniform Administrative Requirements, Cost Principles, and Audit Requirements for Federal Award), to include and not limited to the General Procurement Standards under §200.317 - §200.327. In addition the following provisions are a material part of this Construction Contract.**

(A) Contracts for more than the simplified acquisition threshold, which is the inflation adjusted amount determined by the Civilian Agency Acquisition Council and the Defense Acquisition Regulations Council (Councils) as authorized by 41 U.S.C. 1908, must address administrative, contractual, or legal remedies in instances where contractors violate or breach contract terms, and provide for such sanctions and penalties as appropriate.

(B) All contracts in excess of \$10,000 must address termination for cause and for convenience by the non-Federal entity including the manner by which it will be affected and the basis for settlement.

(C) Equal Employment Opportunity. Except as otherwise provided under 41 CFR Part 60, all contracts that meet the definition of "federally assisted construction contract" in 41 CFR Part 60-1.3 must include the equal opportunity clause provided under 41 CFR 60-1.4(b), in accordance with Executive Order 11246, "Equal Employment Opportunity" (30 FR 12319, 12935, 3 CFR Part, 1964-1965 Comp., p. 339), as amended by Executive Order 11375, "Amending Executive Order 11246 Relating to Equal Employment Opportunity," and implementing regulations at 41 CFR part 60, "Office of Federal Contract Compliance Programs, Equal Employment Opportunity, Department of Labor."

(D) Davis-Bacon Act, as amended (40 U.S.C. 3141-3148). When required by Federal program legislation, all prime construction contracts in excess of \$2,000 awarded by non-Federal entities must include a provision for compliance with the Davis-Bacon Act (40 U.S.C. 3141-3144, and 3146-3148) as supplemented by Department of Labor regulations (29 CFR Part 5, "Labor Standards Provisions Applicable to Contracts Covering Federally Financed and Assisted Construction"). In accordance with the statute, contractors must be required to pay wages to laborers and mechanics at a rate not less than the prevailing wages specified in a wage determination made by the Secretary of Labor. In addition, contractors must be required to pay wages not less than once a week. The non-Federal entity must place a copy of the current prevailing wage determination issued by the Department of Labor in each solicitation. The decision to award a contract or subcontract must be conditioned upon the acceptance of the wage determination. The non-Federal entity must report all suspected or reported violations to the Federal awarding agency. The contracts must also include a provision for compliance with the Copeland "Anti-Kickback" Act (40 U.S.C. 3145), as supplemented by Department of Labor regulations (29 CFR Part 3, "Contractors and Subcontractors on Public Building or Public Work Financed in Whole or in Part by Loans or Grants from the United States"). The Act provides that each contractor or subrecipient must be prohibited from inducing, by any means, any person employed in the construction, completion, or repair of

public work, to give up any part of the compensation to which he or she is otherwise entitled. The non-Federal entity must report all suspected or reported violations to the Federal awarding agency.

(E) Contract Work Hours and Safety Standards Act (40 U.S.C. 3701-3708). Where applicable, all contracts awarded by the non-Federal entity in excess of \$100,000 that involve the employment of mechanics or laborers must include a provision for compliance with 40 U.S.C. 3702 and 3704, as supplemented by Department of Labor regulations (29 CFR Part 5). Under 40 U.S.C. 3702 of the Act, each contractor must be required to compute the wages of every mechanic and laborer on the basis of a standard work week of 40 hours. Work in excess of the standard work week is permissible provided that the worker is compensated at a rate of not less than one and a half times the basic rate of pay for all hours worked in excess of 40 hours in the work week. The requirements of 40 U.S.C. 3704 are applicable to construction work and provide that no laborer or mechanic must be required to work in surroundings or under working conditions which are unsanitary, hazardous or dangerous. These requirements do not apply to the purchases of supplies or materials or articles ordinarily available on the open market, or contracts for transportation or transmission of intelligence.

(F) Rights to Inventions Made Under a Contract or Agreement. If the Federal award meets the definition of "funding agreement" under 37 CFR § 401.2 (a) and the recipient or subrecipient wishes to enter into a contract with a small business Offeror or nonprofit organization regarding the substitution of parties, assignment or performance of experimental, developmental, or research work under that "funding agreement," the recipient or subrecipient must comply with the requirements of 37 CFR Part 401, "Rights to Inventions Made by Nonprofit Organizations and Small Business Offerors Under Government Grants, Contracts and Cooperative Agreements," and any implementing regulations issued by the awarding agency.

(G) Clean Air Act (42 U.S.C. 7401-7671q.) and the Federal Water Pollution Control Act (33 U.S.C. 1251-1387), as amended - Contracts and subgrants of amounts in excess of \$150,000 must contain a provision that requires the non-Federal award to agree to comply with all applicable standards, orders or regulations issued pursuant to the Clean Air Act (42 U.S.C. 7401-7671q) and the Federal Water Pollution Control Act as amended (33 U.S.C. 1251-1387). Violations must be reported to the Federal awarding agency and the Regional Office of the Environmental Protection Agency (EPA).

(H) Debarment and Suspension (Executive Orders 12549 and 12689) - A contract award (see 2 CFR 180.220) must not be made to parties listed on the governmentwide exclusions in the System for Award Management (SAM), in accordance with the OMB guidelines at 2 CFR 180 that implement Executive Orders 12549 (3 CFR part 1986 Comp., p. 189) and 12689 (3 CFR part 1989 Comp., p. 235), "Debarment and Suspension." SAM Exclusions contains the names of parties debarred, suspended, or otherwise excluded by agencies, as well as parties declared ineligible under statutory or regulatory authority other than Executive Order 12549.

(I) Byrd Anti-Lobbying Amendment (31 U.S.C. 1352) - Contractors that apply or bid for an award exceeding

\$100,000 must file the required certification. Each tier certifies to the tier above that it will not and has not used Federal appropriated funds to pay any person or organization for influencing or attempting to influence an officer or employee of any agency, a member of Congress, officer or employee of Congress, or an employee of a member of Congress in connection with obtaining any Federal contract, grant or any other award covered by 31

U.S.C. 1352. Each tier must also disclose any lobbying with non-Federal funds that takes place in connection with obtaining any Federal award. Such disclosures are forwarded from tier to tier up to the non-Federal award.

(J) § 200.323 Procurement of recovered materials. A non-Federal entity that is a state agency or agency of a political subdivision of a state and its contractors must comply with section 6002 of the Solid Waste Disposal Act, as amended by the Resource Conservation and Recovery Act. The requirements of Section 6002 include procuring only items designated in guidelines of the Environmental Protection Agency (EPA) at 40 CFR part 247 that contain the highest percentage of recovered materials practicable, consistent with maintaining a satisfactory level of competition, where the purchase price of the item exceeds \$10,000 or the value of the quantity acquired during the preceding fiscal year exceeded \$10,000; procuring solid waste management services in a manner that maximizes energy and resource recovery; and establishing an affirmative procurement program for procurement of recovered materials identified in the EPA guidelines.

(K) § 200.216 Prohibition on certain telecommunications and video surveillance services or equipment.

(a) Recipients and subrecipients are prohibited from obligating or expending loan or grant funds to:

(1) Procure or obtain;

(2) Extend or renew a contract to procure or obtain; or

(3) Enter into a contract (or extend or renew a contract) to procure or obtain equipment, services, or systems that uses covered telecommunications equipment or services as a substantial or essential component of any system, or as critical technology as part of any system. As described in Public Law 115-232, section 889, covered telecommunications equipment is telecommunications equipment produced by Huawei Technologies Offeror or ZTE Corporation (or any subsidiary or affiliate of such entities).

(i) For the purpose of public safety, security of government facilities, physical security surveillance of critical infrastructure, and other national security purposes, video surveillance and telecommunications equipment produced by Hytera Communications Corporation, Hangzhou Hikvision Digital Technology Offeror, or Dahua Technology Offeror (or any subsidiary or affiliate of such entities).

(ii) Telecommunications or video surveillance services provided by such entities or using such equipment.

(iii) Telecommunications or video surveillance equipment or services produced or provided by an entity that the Secretary of Defense, in consultation with the Director of the National Intelligence or the Director of the Federal Bureau of Investigation, reasonably believes to be an entity owned or controlled by, or otherwise connected to, the government of a covered foreign country.

(b) In implementing the prohibition under Public Law 115-232, section 889, subsection (f), paragraph (1), heads of executive agencies administering loan, grant, or subsidy programs shall prioritize available funding and technical support to assist affected businesses, institutions and organizations as is reasonably

necessary for those affected entities to transition from covered communications equipment and services, to procure replacement equipment and services, and to ensure that communications service to users and customers is sustained.

(c) See Public Law 115-232, section 889 for additional information.

(d) See also § 200.471.

(l) § 200.322 Domestic preferences for procurements.

(a) As appropriate and to the extent consistent with law, the non-Federal entity should, to the greatest extent practicable under a Federal award, provide a preference for the purchase, acquisition, or use of goods, products, or materials produced in the United States (including but not limited to iron, aluminum, steel, cement, and other manufactured products). The requirements of this section must be included in all subawards including all contracts and purchase orders for work or products under this award.

(b) For purposes of this section:

(1) "Produced in the United States" means, for iron and steel products, that all manufacturing processes, from the initial melting stage through the application of coatings, occurred in the United States.

(2) "Manufactured products" means items and construction materials composed in whole or in part of non-ferrous metals such as aluminum; plastics and polymer-based products such as polyvinyl chloride pipe; aggregates such as concrete; glass, including optical fiber; and lumber.